



**Moss & Associates, LLC**  
 6363 NW 6th Way  
 Ft Lauderdale, FL 33309

May 12, 2026

Ronald Stein  
 City of Fort Lauderdale  
 101 NE 3rd Ave, Suite 2100  
 Ft. Lauderdale, FL 33301

RE: Potential Change Item (PCI) 0339 Notification  
 Fort Lauderdale Police Headquarters - B372302

Dear Ronald Stein,

This letter is to provide official notification of a potential change item (PCI) as follows:

PCI Number: 0339  
 Date: September 16, 2025  
 Description: SI-006 Site Plan Revision  
 Days Requested:  
 Reason: Owner Directive - External  
 Scope Description: SI-006 Site Plan revision based on permit revision set received 2/5/26. Includes dumpster addition, south parking changes, added slide gate and fencing, tree removal, and landscaping.

This scope is pending approval of PCI 353 for time extension based on Phase II delayed start, which places current Substantial Completion date on August 5<sup>th</sup>, 2026. Approval of this PCI 339 on May 19<sup>th</sup>, 2026, incurs an additional time extension of (55) calendar days, and the new Substantial Completion date after approval of PCI 339 would therefore be September 28<sup>th</sup>, 2026. Associated General Conditions and General Requirements for (1) month have been included in this PCI. See attached remaining work schedule as of April 30<sup>th</sup>, 2026 which includes projected May 19<sup>th</sup>, 2026 approval date for this PCI.

This PCI is comprised of the following items:

Noury SI-006 Earthwork, paving, and tree removal.	\$ 190,967.34
Tekton SI-006 Dumpster Enclosure	\$ 66,273.21
A-Better Plumbing SI-006 Hose Bib	\$ 14,502.55
Emm Trace SI-006 Louvered Dumpster Gates	\$ 23,105.67
Thunder Electrical SI-006	\$ 30,041.00
Bermuda Landscaping SI-006	\$ 3,475.25
Fencemasters SI-006 Aluminum Security Gate & Fencing & Chain Link Fence	\$ 93,505.00
Tekton - Pour back PG slab on grade after drainage installation	\$ 19,927.00
A Better - Demo PG slab and tie into existing sanitary line. Includes oil/water separator.	\$ 34,751.11
(1) Month General Conditions	\$ 70,000.00
(1) Month General Requirements	\$ 30,000.00
01 Subcontract Default Insurance 1.25%	\$ 5,956.85
02 Moss Insurance 1.75%	\$ 10,089.59
03 Bond 1%	\$ 5,765.48
04 Fee 4%	\$ 23,061.93

<b>Grand Total</b>	<b>\$621,421.98</b>
--------------------	---------------------

Per the terms and conditions of our contract, we have attached the appropriate back up documentation to substantiate the above referenced costs. This request only includes the items specifically identified in this change proposal. All other costs associated with this project shall be submitted under a separate change order cover.

The costs associated with this PCI will remain valid for fourteen (14) calendar days after submission.

Please indicate your formal approval for this additional work and cost by signing in the space provided below. Moss & Associates will then incorporate this change into the next Owner Change Order (OCO).

If you should have any questions, please contact the undersigned at 954-326-2727 as soon as possible.

<p>Sincerely, <b>Moss &amp; Associates, LLC</b></p> <p>_____ Date: _____</p> <p>Matthew Kane Project Manager</p>	<p>Reviewed / Approved by: <b>City of Fort Lauderdale</b></p> <p><b>Approved:</b> _____ <b>Date:</b> _____ (Owner)</p>
--	--

REMAINING WORK

Activity ID	Activity Name	OD	Start	Finish	Total Float	2026											
						Apr	May	Jun	Jul	Aug	Sep	Oct	Nov	Dec			
<b>FT LAUDERDALE POLICE HEADQUARTERS - DD 04-30-26</b>																	
<b>PROJECT DELAYS</b>																	
<b>Delay 06D: Kitchen/Cafeteria Design</b>																	
PD06D-070.1	Delay 06D: Procure Kitchen Equipment	40	16-Mar-26 A	05-Jun-26	-91	Delay 06D: Procure Kitchen Equipment											
<b>Delay 15: Fence, Gate and Dumpster Revision</b>																	
PD15-050	City Issue OCO for Revised Fence and Gate Design	10	24-Dec-25 A	19-May-26	-139	City Issue OCO for Revised Fence and Gate Design											
PD15-060	Tree Removal	10	20-May-26	04-Jun-26	-99	Tree Removal											
PD15-090	Construct Dumpster Enclosure	40	20-May-26	20-Jul-26	-114	Construct Dumpster Enclosure											
PD15-100	Prep/Submit Gate Shop Drawings	10	20-May-26	04-Jun-26	-139	Prep/Submit Gate Shop Drawings											
PD15-070	Demo and Re Grade South Lot	10	05-Jun-26	18-Jun-26	-99	Demo and Re Grade South Lot											
PD15-080	A/E Review Gate Shop Drawings	10	05-Jun-26	18-Jun-26	-139	A/E Review Gate Shop Drawings											
PD15-030	Procure and Fabricate Additional Fence and Gate Material	40	19-Jun-26	17-Aug-26	-139	Procure and Fabricate Additional Fence and Gate Material											
<b>Delay 18: Faraday Room Spec Change</b>																	
PD18-050	Fabricate Faraday Room	72	03-Mar-26 A	12-Jun-26	-103	Fabricate Faraday Room											
PD18-100	Build Out Vestibule	20	01-Jun-26	26-Jun-26	-93	Build Out Vestibule											
PD18-060	Install Faraday Room	10	15-Jun-26	26-Jun-26	-103	Install Faraday Room											
PD18-070	MEPF Trimout	10	23-Jun-26	08-Jul-26	-103	MEPF Trimout											
PD18-090	Install Cabinets	3	09-Jul-26	13-Jul-26	-103	Install Cabinets											
PD18-080	Perform Faraday Room Testing	1	14-Jul-26	14-Jul-26	-103	Perform Faraday Room Testing											
<b>NEW PARKING GARAGE</b>																	
<b>CONSTRUCTION</b>																	
<b>NEW SITE WORK</b>																	
<b>SOUTH SITE WORK</b>																	
PSWS 10200	INSTALL FENCING	10	14-Jul-25 A	17-Aug-26	-139	INSTALL FENCING											
PSWS 10190	FINAL LIFT OF ASPHALT	2	18-Aug-26	19-Aug-26	-134	FINAL LIFT OF ASPHALT											
PSWS 10210	STRIPING & SIGNAGE	4	18-Aug-26	21-Aug-26	-139	STRIPING & SIGNAGE											
PSWS 10220	FINAL MEP TRIM	3	24-Aug-26	26-Aug-26	-139	FINAL MEP TRIM											
PSWS 10230	CLEAN UP & PUNCH OUT	5	27-Aug-26	02-Sep-26	-139	CLEAN UP & PUNCH OUT											
<b>PHASE 1 NEW FT LAUDERDALE POLICE HEADQUARTERS</b>																	
<b>CONSTRUCTION</b>																	
<b>INTERIOR FINISHES</b>																	
<b>NEW 2ND FLOOR</b>																	
<b>INTERIOR 2ND FLOOR AREA A</b>																	
<b>KITCHEN / CAFETERIA</b>																	
NIF2 20600	INSTALL KITCHEN HOOD	5	28-Apr-26 A	11-May-26	-82	INSTALL KITCHEN HOOD											
NIF2 20620	ACOUSTIC GRID KITCHEN	3	12-May-26	14-May-26	-82	ACOUSTIC GRID KITCHEN											

█ Remaining Level of Effort    █ Critical Remaining Work  
█ Actual Level of Effort    █ Actual Work  
█ Remaining Work    ◆ ◆ Milestone



Activity ID	Activity Name	OD	Start	Finish	Total Float	2026											
						May	Jun	Jul	Aug	Sep	Oct	Nov	Dec				
NIF2 20630	MEP RI GRID KITCHEN	6	14-May-26	21-May-26	-82	■ MEP RI GRID KITCHEN											
NIF2 20675	INSTALL KITCHEN EQUIPMENT / CONNECT MEP	6	08-Jun-26	15-Jun-26	-91	■ INSTALL KITCHEN EQUIPMENT / CONNECT MEP											
NIF2 20640	ACOUSTIC TILE KITCHEN	3	16-Jun-26	18-Jun-26	-91	■ ACOUSTIC TILE KITCHEN											
NIF2 20685	START UP KITCHEN	3	16-Jun-26	18-Jun-26	-87	■ START UP KITCHEN											
NIF2 20680	KITCHEN MILLWORK CAFETERIA	6	19-Jun-26	26-Jun-26	-91	■ KITCHEN MILLWORK CAFETERIA											
NIF2 20690	MEPF TRIM	5	25-Jun-26	01-Jul-26	-91	■ MEPF TRIM											
NIF2 20695	CLEAN UP & PUNCHOUT	5	29-Jun-26	07-Jul-26	-88	■ CLEAN UP & PUNCHOUT											
<b>NEW POLICE HEADQUARTERS COMPLETION</b>		<b>307</b>	<b>15-Jul-25 A</b>	<b>28-Sep-26</b>	<b>-139</b>												
<b>PHASE 1B</b>		<b>307</b>	<b>15-Jul-25 A</b>	<b>28-Sep-26</b>	<b>-139</b>												
PC 99110-B	COMPLETE / TEST MEP SYSTEMS / TRADE CONT FINAL INSPECTIONS -	10	15-Jul-25 A	26-Aug-26	-129	■ COMPLETE / TEST MEP SYSTEMS / TRADE CONT FINAL											
PC 99120-1B	FINAL CLEAN UP & PUNCH - PHASE 1B	10	03-Sep-26	18-Sep-26	-139	■ FINAL CLEAN UP & PUNCH - PHASE 1B											
PC 99130-1B	CERTIFICATE OF OCCUPANCY / SUBSTANTIAL COMPLETION - PHASE 1E	5	21-Sep-26	25-Sep-26	-139	■ CERTIFICATE OF OCCUPANCY / SUBSTANTIAL COMPLETION - PHASE 1E											
PC 99140-1B	SUBSTANTIAL COMPLETION - PHASE 1B	1	28-Sep-26	28-Sep-26*	-139	■ SUBSTANTIAL COMPLETION - PHASE 1B											
<b>PHASE 2 DEMO OF EXISTING HQ AND SITEWORK</b>		<b>62</b>	<b>09-Apr-26 A</b>	<b>15-Jul-26</b>	<b>-88</b>												
<b>SITE WORK</b>		<b>62</b>	<b>09-Apr-26 A</b>	<b>15-Jul-26</b>	<b>-88</b>												
P2SW 10160	INSTALL UNDERGROUND ELECTRICAL	10	09-Apr-26 A	14-May-26	-77	■ INSTALL UNDERGROUND ELECTRICAL											
P2SW 10240	LIMEROCK FOR PAVERS	5	28-Apr-26 A	20-May-26	-77	■ LIMEROCK FOR PAVERS											
P2SW 10180	1ST LIFT ASPHALT	3	01-May-26	05-May-26	-88	■ 1ST LIFT ASPHALT											
P2SW 10260	LANDSCAPE PLANTERS	8	06-May-26	15-May-26	-88	■ LANDSCAPE PLANTERS											
P2SW 10150	INSTALL LIGHT POLE BASES	4	15-May-26	20-May-26	-77	■ INSTALL LIGHT POLE BASES											
P2SW 10300	CURBS	10	15-May-26	01-Jun-26	-88	■ CURBS											
P2SW 10310	FORM & POUR SIDEWALKS	4	15-May-26	20-May-26	-88	■ FORM & POUR SIDEWALKS											
P2SW 10270	STUCCO WALLS	5	18-May-26	22-May-26	-79	■ STUCCO WALLS											
P2SW 10280	PAINT WALLS	5	27-May-26	02-Jun-26	-67	■ PAINT WALLS											
P2SW 10320	INSTALL LANDSCAPING	10	27-May-26	09-Jun-26	-79	■ INSTALL LANDSCAPING											
P2SW 10290	INSTALL PAVERS	20	02-Jun-26	29-Jun-26	-88	■ INSTALL PAVERS											
P2SW 10330	INSTALL LIGHT POLS	8	10-Jun-26	19-Jun-26	-79	■ INSTALL LIGHT POLS											
P2SW 10340	INSTALL SITE LIGHTING	5	26-Jun-26	06-Jul-26	-88	■ INSTALL SITE LIGHTING											
P2SW 10325	INSTALL HANDRAILS	3	30-Jun-26	06-Jul-26	-86	■ INSTALL HANDRAILS											
P2SW 10350	FINAL LIFT ASPALT	3	07-Jul-26	09-Jul-26	-88	■ FINAL LIFT ASPALT											
P2SW 10380	MEP TRIM	5	07-Jul-26	13-Jul-26	-88	■ MEP TRIM											
P2SW 10390	CLEAN-UP & PUNCH OUT	5	09-Jul-26	15-Jul-26	-88	■ CLEAN-UP & PUNCH OUT											
P2SW 10360	STRIPING	3	10-Jul-26	14-Jul-26	-87	■ STRIPING											
P2SW 10370	SIGNAGE	3	10-Jul-26	14-Jul-26	-88	■ SIGNAGE											
P2SW 10395	SITE INSPECTIONS	3	10-Jul-26	14-Jul-26	-87	■ SITE INSPECTIONS											
P2SW 10400	CERTIFICATE OF COMPLETION PHASE 2	0		15-Jul-26*	-88	◆ CERTIFICATE OF COMPLETION PHASE 2											

■ Remaining Level of Effort    ■ Critical Remaining Work  
■ Actual Level of Effort        ■ Actual Work  
■ Remaining Work                    ◆ ◆ Milestone





**FLPD HQ & PG  
1300-1350 W BROWARD BLVD  
FORT LAUDERDALE, FL**

**COR-22 REV-2  
SI-006 ADMIN REVIEW 08/15/2025**

date: **February 10, 2026**

submit to: **MOSS CONSTRUCTION  
2101 N ANDREWS AVENUE  
FORT LAUDERDALE, FL 33311  
Matthew Kane  
MKane@mosscon.com**

job name: **FLPD HQ & PG  
1300-1350 W BROWARD BLVD  
FORT LAUDERDALE, FL**

designer: **AECOM - KEITH  
PROJ NO. 11112.00 SI-006 SET D: 8/15/2025**

**SCOPE OF WORK:**

**EARTHWORK CHANGES**

**1.- DEMOLITION -**

REMOVE AND DISPOSE ASPHALT, CURB, SIDEWALK, TREES

1.-	<b>ADD DEMOLITION TREES</b>		3 EA		
2.-	<b>ADD DEMOLITION ASPHALT</b>		1589 SF		
3.-	<b>ADD DEMOLITION CURB</b>		232 LF		
4.-	<b>ADD DEMOLITION SIDEWALK</b>		245 SF		
5.-	<b>DEMO CREW</b>				
	Excavator 328	1.0 hr.		\$ 215.00	\$215.00
	Dozer D-3 CAT	1.0 hr.		\$ 100.00	\$100.00

**NOURY CONSTRUCTION CO.**

4851W HILLSBORO BLVD., STE A-8 - COCONUT CREEK, FL 33073  
MAIN 954.227.0138 - FAX 954.420.9391



Loader 3cy. CAT	1.0 hr.	\$ 115.00	\$115.00	
Demo Trailer	1.0 hr.	\$ 145.00	\$145.00	
Foreman with pic	1.0 hr.	\$ 75.00	\$75.00	
Labor	2.0 hr.	\$ 30.00	\$60.00	
Total Demo Crew	1.0 hr.		\$710.00	
<b>6.- SUB TOTAL DEMO CREW</b>	<b>35.0 HR</b>		<b>\$</b>	<b>24,850.00</b>
<b>7.- CUT DOWN TREES</b>	<b>1 LD</b>	<b>\$ 9,500.00</b>	<b>\$</b>	<b>9,500.00</b>
<b>8.- DISPOSAL TREES</b>	<b>50 TN</b>	<b>\$ 75.00</b>	<b>\$</b>	<b>3,750.00</b>
<b>9.- DISPOSAL ASPHALT</b>	<b>1 LD</b>	<b>\$ 350.00</b>	<b>\$</b>	<b>350.00</b>
<b>10.- DISPOSAL CONCRETE</b>	<b>1 LD</b>	<b>\$ 350.00</b>	<b>\$</b>	<b>350.00</b>
<b>11.- SAWCUT ASPHALT</b>	<b>200 LF</b>	<b>\$ 2.00</b>	<b>\$</b>	<b>400.00</b>

**SUB-TOTAL ADD DEMOLITION** **\$ 39,200.00**

**SUB-BASE CHANGES**

REMOVE TOP SOIL AND ADD STABILIZER TO SUBGRADE NEW ASPHALT AREAS

<b>ADD ASPH REST 1.5" SP-9.5 &amp; 8" L</b>	<b>3973 SF</b>			
<b>ADD TRENCH 1.5 SP-12.5 ASPHALT AI</b>	<b>550 SF</b>			
<b>MATERIALS</b>	<b>QUANT.</b>	<b>UNIT</b>	<b>UNIT PRICE</b>	<b>TOTAL PRICE</b>
1.- LBR	328.37	TN	\$ 17.90	\$5,877.82
3.- TAX	5,877.82	\$	7%	\$411.45
<b>4.- SUB TOTAL MATERIAL</b>				<b>\$ 6,729.52</b>
<b>5.- GRADING CREW</b>				
Dozer D-3 CAT	1.0 hr.	\$ 100.00	\$100.00	
Loader 3cy. CAT	1.0 hr.	\$ 115.00	\$115.00	
Dump Truck	1.0 hr.	\$ 90.00	\$90.00	
Roller	1.0 hr.	\$ 90.00	\$90.00	
Water Truck	1.0 hr.	\$ 75.00	\$75.00	
Foreman with pic	1.0 hr.	\$ 75.00	\$75.00	
Labor	2.0 hr.	\$ 30.00	\$60.00	
Total Grading Cre	1.0 hr.		\$605.00	
<b>6.- SUB TOTAL GRADING CREW</b>	<b>60.0 HR</b>		<b>\$</b>	<b>36,287.09</b>
<b>7.- LAYOUT</b>			<b>\$</b>	<b>2,450.00</b>

**SUB-TOTAL ADD SUB-BASE** **\$ 45,466.61**

**TOTAL ADD EARTHWORK** **\$ 84,666.61**

**PAVING SYSTEM CHANGES**

**ASPHALT CHANGES**



CHANGE CONFIGURATION OF SOUTH PARKING LOT AND EXPAND DRIVEWAY WEST OF HQ TO ADD 3' ISLAND INSTALL 8" LIMEROCK BASE, AND 1.5" OF ASPHALT ADD ONE MOBILIZATION. RESTORATION OF ELECTRICAL TRENCHES HAND WORK.

	QUANT.	UNIT	UNIT PRICE	TOTAL PRICE
<b>ADD 1.5 SP-12.5 ASPHALT AND 8" LIM</b>	442	SY		
<b>ADD TRENCH 1.5 SP-12.5 ASPHALT AI</b>	62	SY		
<b>MATERIALS</b>				
1.-				
2.- LIMEROCK	219.54	TN	\$ 33.97	\$7,457.86
3.- TAX	7,457.86	\$	7%	\$522.05
4.- <b>SUB TOTAL MATERIAL</b>				<b>\$ 8,538.50</b>
5.- <b>GRADING CREW</b>				
Grader 140M CA	1.0	hr.	\$ 150.00	\$150.00
Dozer D-3 CAT	1.0	hr.	\$ 100.00	\$100.00
Loader 3cy. CAT	1.0	hr.	\$ 115.00	\$115.00
Roller	1.0	hr.	\$ 90.00	\$90.00
Water Truck	1.0	hr.	\$ 75.00	\$75.00
Foreman with pic	1.0	hr.	\$ 75.00	\$75.00
Labor	2.0	hr.	\$ 30.00	\$60.00
Total Grading Cre	1.0	hr.		\$665.00
6.- <b>SUB TOTAL GRADING CREW</b>	48.0	HR		<b>\$ 31,920.00</b>
7.- <b>ASPH MOB</b>	1	LS	4,800.00	<b>\$ 4,800.00</b>
8.- <b>PRIME</b>	504	SY	0.35	<b>\$ 176.40</b>
9.- <b>ASPH 0.75" TYPE SP-12.5 FIRST LIFT</b>	504	SY	19.50	<b>\$ 9,828.00</b>
10.- <b>ASPH 0.75" TYPE SP-12.5 FINAL LIFT</b>	504	SY	20.00	<b>\$ 10,080.00</b>
11.- <b>ADD 1" MILLING</b>	90	SY	4.50	<b>\$ 405.00</b>
12.- <b>ADD 1" SP-9.5 OVERLAY</b>	90	SY	20.00	<b>\$ 1,800.00</b>
13.- <b>LAYOUT</b>				<b>\$ 1,400.00</b>
<b>TOTAL ADD ASPHALT</b>				<b>\$ 68,947.90</b>

**CONCRETE WORK CHANGES**

CHANGE CONFIGURATION OF SOUTH PARKING LOT.

<b>ADD 6" SIDEWALK</b>	245	SF
<b>ADD ADA TILE</b>	24	SF
<b>ADD TYPE F CURB</b>	30	FT
<b>ADD DROP CURB</b>	46	FT
<b>DELETE TYPE D CURB</b>	-304	FT
<b>ADD TYPE D CURB</b>	291	FT
<b>DELETE GATE ISLANDS 5'X3'</b>	-1	EA
<b>ADD GATE ISLAND 5'X3'</b>	1	EA

NOURY CONSTRUCTION CO.

4851W HILLSBORO BLVD., STE A-8 - COCONUT CREEK, FL 33073  
 MAIN 954.227.0138 - FAX 954.420.9391

CAM #26-0510  
 Exhibit 3  
 Page 7 of 262



ADD GATE ISLAND 10'X3' MATERIALS		1 EA	QUANT.	UNIT	UNIT PRICE	TOTAL PRICE
1.-						
2.-	LIMEROCK (UNDER CURB ISLANDS)	22 TN			\$ 33.97	\$747.34
3.-	TAX	747.34	\$		7%	\$52.31
4.-	<b>SUB TOTAL MATERIAL</b>					<b>\$ 855.63</b>
5.-	<b>GRADING CREW</b>					
	Dozer D-3 CAT	1.0 hr.			\$ 100.00	\$100.00
	Loader 3cy. CAT	1.0 hr.			\$ 115.00	\$115.00
	Roller	1.0 hr.			\$ 90.00	\$90.00
	Water Truck	1.0 hr.			\$ 75.00	\$75.00
	Foreman with pic	1.0 hr.			\$ 75.00	\$75.00
	Labor	2.0 hr.			\$ 30.00	\$60.00
	Total Grading Cre	1.0 hr.				\$515.00
6.-	<b>SUB TOTAL GRADING CREW</b>	20.0 HR				<b>\$ 10,300.00</b>
7.-	<b>6" SIDEWALK</b>	245 SF			7.15	<b>\$ 1,751.75</b>
8.-	<b>ADA TILE</b>	24 SF			45.00	<b>\$ 1,080.00</b>
9.-	<b>TYPE F CURB</b>	30 LF			32.00	<b>\$ 960.00</b>
10.-	<b>DROP CURB</b>	46 LF			32.00	<b>\$ 1,472.00</b>
11.-	<b>TYPE D CURB</b>	-13 LF			12.00	<b>\$ (156.00)</b>
12.-	<b>GATE ISLANDS 10'X3'</b>	1 EA			1,000.00	<b>\$ 1,000.00</b>
13.-	<b>LAYOUT</b>					<b>\$ 1,575.00</b>

**TOTAL ADD CONCRETE WORK CHANGES \$ 18,838.38**

**MARKINGS AND SIGNS**

CHANGES TO SOUTH PARKING LOT

1.-	DELETE CAR STOP	-14 EA	\$	40.00	\$	(560.00)
2.-	DELETE 4" WHITE PAINT & THERMO	-258 LS	\$	1.35	\$	(348.30)
3.-	ADD 24" WHITE STOP BAR PAINT & TI	24 LF	\$	8.75	\$	210.00
4.-	ADD 6" DOUBLE YELLOW PAINT & TH	140 LF	\$	3.40	\$	476.00
5.-	ADD 4" WHITE PAINT & THERMO	634 LF	\$	1.35	\$	855.90
6.-	ADD STOP SIGN	1 EA	\$	875.00	\$	875.00
7.-	LAYOUT				\$	700.00

**TOTAL ADD MARKINGS AND SIGNS \$ 2,208.60**

**TOTAL ADD PAVING SYSTEM \$ 89,994.88**

**DRAINAGE CONNECTION**

ADD A DRAINAGE CONNECTION FROM THE OLI/WATER SEPARATOR CO (BY OTHERS) TO STRUCTURE 40. **YD, OIL/WATER SEPARATOR, CO'S ARE NOT INCLUDED.**

NOURY CONSTRUCTION CO.

4851W HILLSBORO BLVD., STE A-8 - COCONUT CREEK, FL 33073  
 MAIN 954.227.0138 - FAX 954.420.9391

CAM #26-0510  
 Exhibit 3  
 Page 8 of 262



1.- MATERIALS	QUANT.	UNIT	UNIT PRICE	TOTAL PRICE
2.- ADD 6" PVC SDR-26 PIPE	14	LF	\$ 10.00	\$ 140.00
3.- ADD MH ADAPTER	1	EA	\$ 250.00	\$ 250.00
4.- ADD MISC MATERIAL TIE-IN	1	EA	\$ 350.00	\$ 350.00
5.- TAX		\$	7%	\$ 51.80
6.- <b>SUB TOTAL MATERIAL</b>				<b>\$ 847.23</b>
7.- <b>UNDERGROUND CREW 80K LB EXC</b>				
Excavator 308	1.0	hr.	\$ 100.00	\$100.00
Loader 3cy.	1.0	hr.	\$ 115.00	\$115.00
Shoring	1.0	hr.	\$ 27.73	\$27.73
Dewatering	1.0	hr.	\$ 18.00	\$18.00
Foreman with pic	1.0	hr.	\$ 75.00	\$75.00
Pipe Layer	1.0	hr.	\$ 40.00	\$40.00
Hillman	1.0	hr.	\$ 35.00	\$35.00
Labor	1.0	hr.	\$ 30.00	\$30.00
Total Und Crew	1.0	hr.		\$440.73
8.- <b>SUB TOTAL UNDERGROUND CREW</b>	10.0	HR		<b>\$ 4,407.25</b>
9.- <b>SUB CORING STRUCTURE</b>				<b>\$ 1,500.00</b>
10.- <b>LAYOUT</b>				<b>\$ 700.00</b>
<b>TOTAL DRAINAGE CONNECTION</b>				<b>\$ 7,454.48</b>
<b><u>SUB-TOTAL PROPOSAL</u></b>				<b><u>\$ 182,115.96</u></b>
<b>OVERHEAD AND PROFIT 10%</b>				<b><u>\$ 18,211.60</u></b>
<b>BOND FEE ADD 2%</b>				<b><u>NIC</u></b>
<b><u>TOTAL</u></b>				<b><u>\$ 200,327.56</u></b>

**NOURY CONSTRUCTION CO.**

4851W HILLSBORO BLVD., STE A-B - COCONUT CREEK, FL 33073  
 MAIN 954.227.0138 - FAX 954.420.9391



NOT INCLUDED :

PERMIT FEES – PAVERS FOR MEDIAN – LANDSCAPING – DUMPSTER SLAB, ENCLOSURE WALLS, GATES, BOLLARDS –

***DUE TO A CONTINUE PRICE INCREASES ON A VARIETY OF MATERIALS, OUR PRICES ARE EFFECTIVE FOR 30 DAYS, AFTER SUCH TIME WE WILL HAVE TO REEVALUATE OUR QUOTE. WE APOLOGIZE FOR ANY INCONVENIENCE THAT THIS MAY CAUSE YOU AND THE OWNER.***

If you have any questions please contact me at your convenience.

**Noury Construction Co.**

A handwritten signature in blue ink that reads "Michel E. Noury". The signature is written in a cursive style with a long horizontal line extending to the left.

**MICHEL E. NOURY  
PRESIDENT**

**NOURY CONSTRUCTION CO.**

4851W HILLSBORD BLVD., STE A-8 - COCONUT CREEK, FL 33073  
MAIN 954.227.0138 - FAX 954.420.9391

CAM #26-0510  
Exhibit 3  
Page 10 of 262



## Estimate

For: Noury Construction Co.  
 Mnoury@nouryconstruction.com  
 4851 W Hillsboro Blvd A8, Coconut Creek, FL 33073  
 (954) 275-3075

Estimate No: 409  
 Date: 05/14/2025

Description	Quantity	Rate	Amount
Job location: Fort Lauderdale Police Department.	1	\$6,000.00	\$6,000.00*
Remove (2) Live Oak trees from the south side of the property, behind the new parking garage. The trees will be deconstructed from the top-down using our grapplesaw crane. All debris will be hauled away. The stumps will be left 3 feet tall.			
Stump grind the roots of the trees within the exposed area to facilitate easier stump excavation.	1	\$1,500.00	\$1,500.00*
Remove (1) additional Mahogany tree in the same area.	1	\$1,500.00	\$1,500.00*
The tree will be deconstructed from the top-down using our grapplesaw crane.			
Stump grind the roots of the trees within the exposed area to facilitate easier stump excavation.	1	\$500.00	\$500.00*

\*Indicates non-taxable item

Subtotal \$9,500.00  
 Total \$9,500.00

**Total \$9,500.00**

### Comments

TREE REMOVAL – Complete removal of a tree as close to the ground as possible and cleanup of all debris (unless otherwise stated) Additional charges will be levied for unseen concrete or metal in tree upon notification of owner.  
 STUMP REMOVAL – Mechanical grinding of the visible tree stump to below ground level (We are not responsible for any underground property). Stump hole will be back-filled with stump chips and excess chips left on site (unless otherwise stated on proposal or work order). These chips are an excellent landscape mulch.  
 ROOT PRUNING – Root pruning weakens tree's stability. We will not be responsible for tree's stability after the fact or underground pipes, sprinkler lines, etc. Root pruning can also cause a tree or shrub to go into shock or die.  
 PERMITS – Customer will be responsible to pull permits for any work to be done that warrants such. FARINA TREE CARE, LLC will be held harmless in the event customer neglects to do so.  
 OWNERSHIP OF TREES – Client guarantees that the trees quoted are either his/her own or that they have received

written permission to work on the trees which are not their property.

PLANTING OF NEW TREES – Client is responsible for care of new trees. Should any of the new trees die due to any reason not directly related to faulty installation, FARINA TREE CARE, LLC cannot be held liable for any compensation.

TERMS AND CONDITIONS – Unless otherwise agreed to and indicated hereon, the customer agrees to settle their account with FARINA TREE CARE, LLC. FARINA TREE CARE, LLC cannot be held responsible for any damage done underground by one of our stump grinders or any other piece of equipment due to the fact that we do not know the location of water pipes, phone lines, power lines, cables lines, drainage or sprinkler systems. We regret any inconvenience that this may cause. The debtor assumes all cost of collection, including but not limited to interest, court costs, and reasonable attorney fees.

CONSTRUCTION OVER WHERE THE TREE WAS REMOVED- Farina tree care is not liable for any damages caused by ground settlement after tree removal or stump grinding.

Photo 1

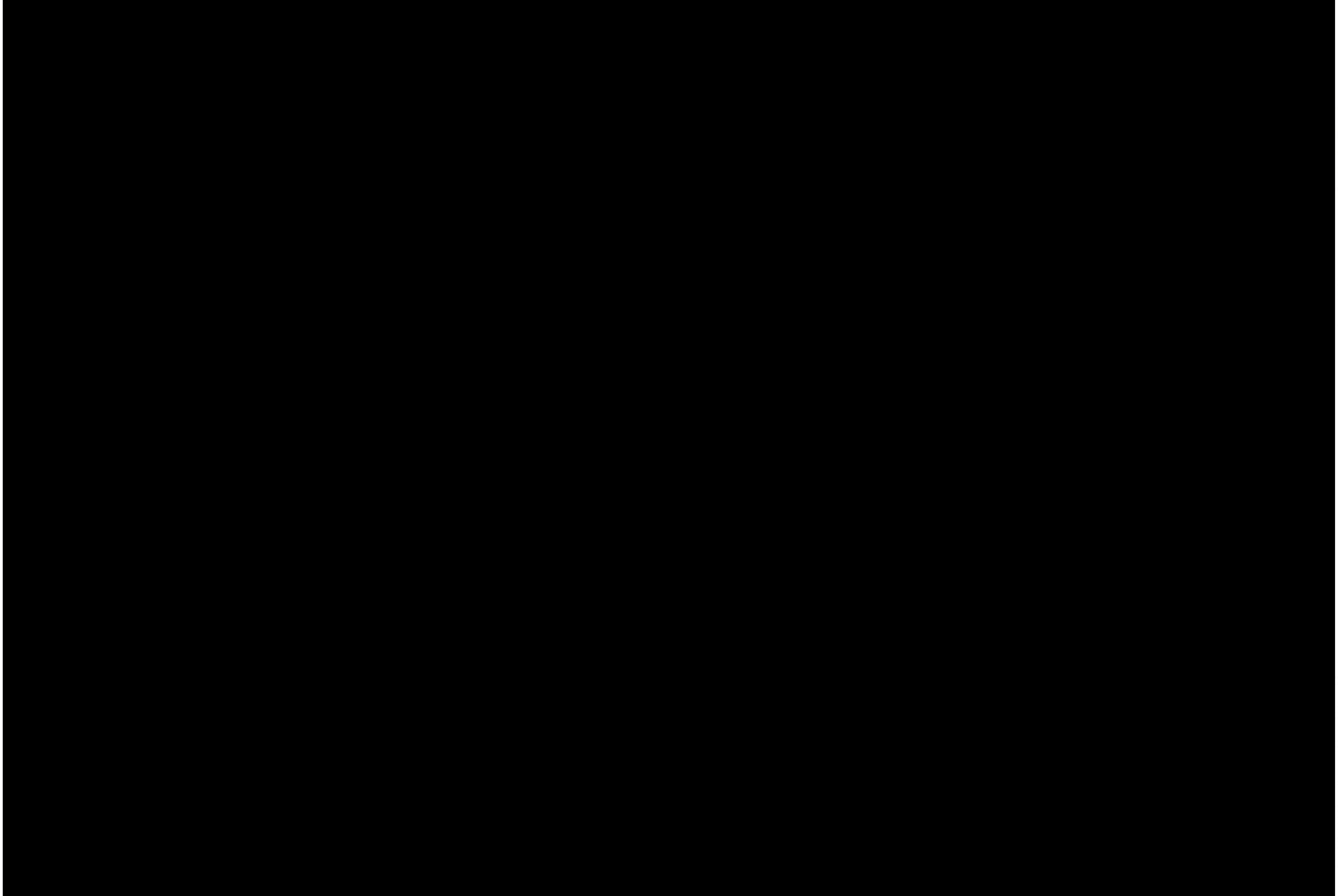


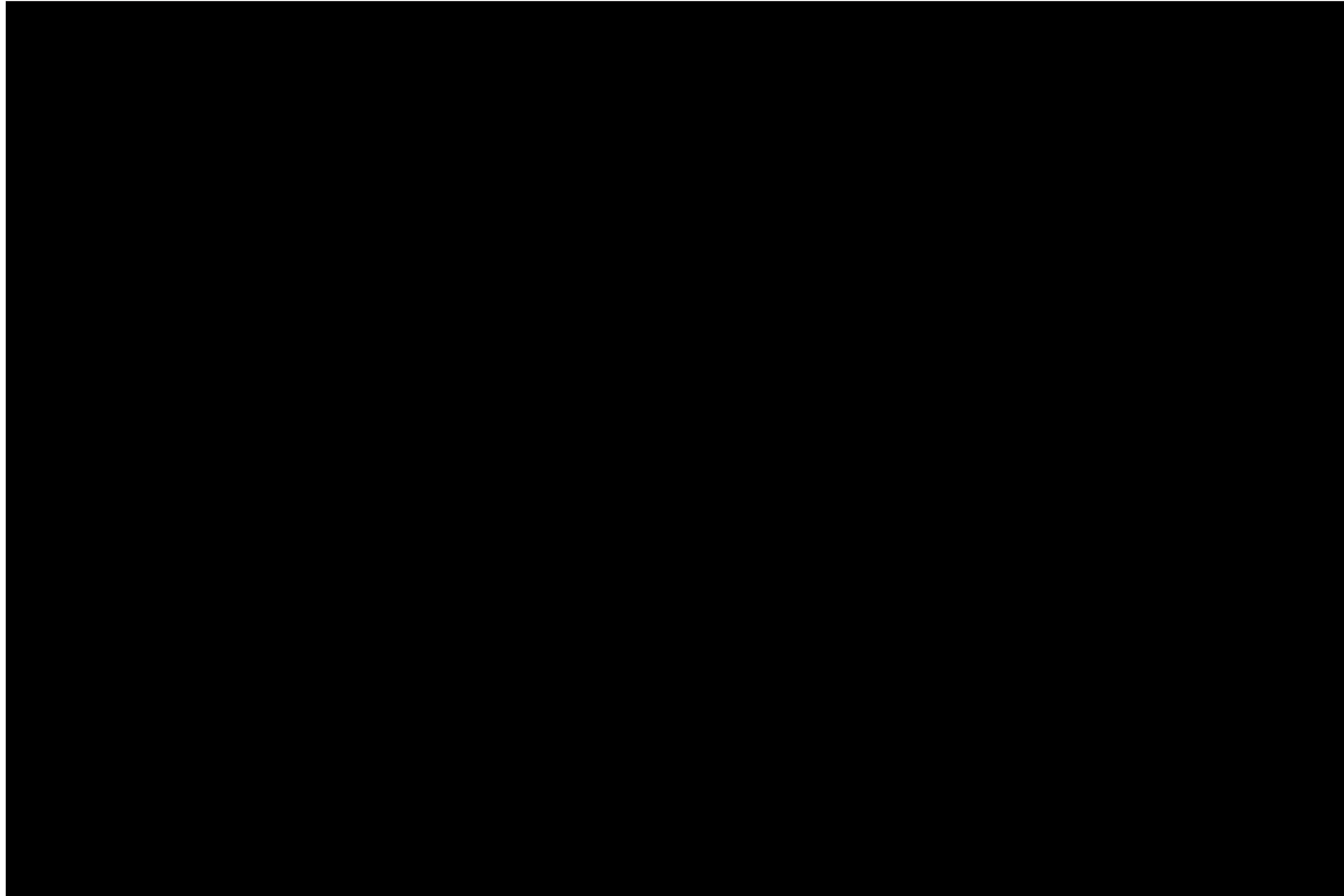
Photo 2

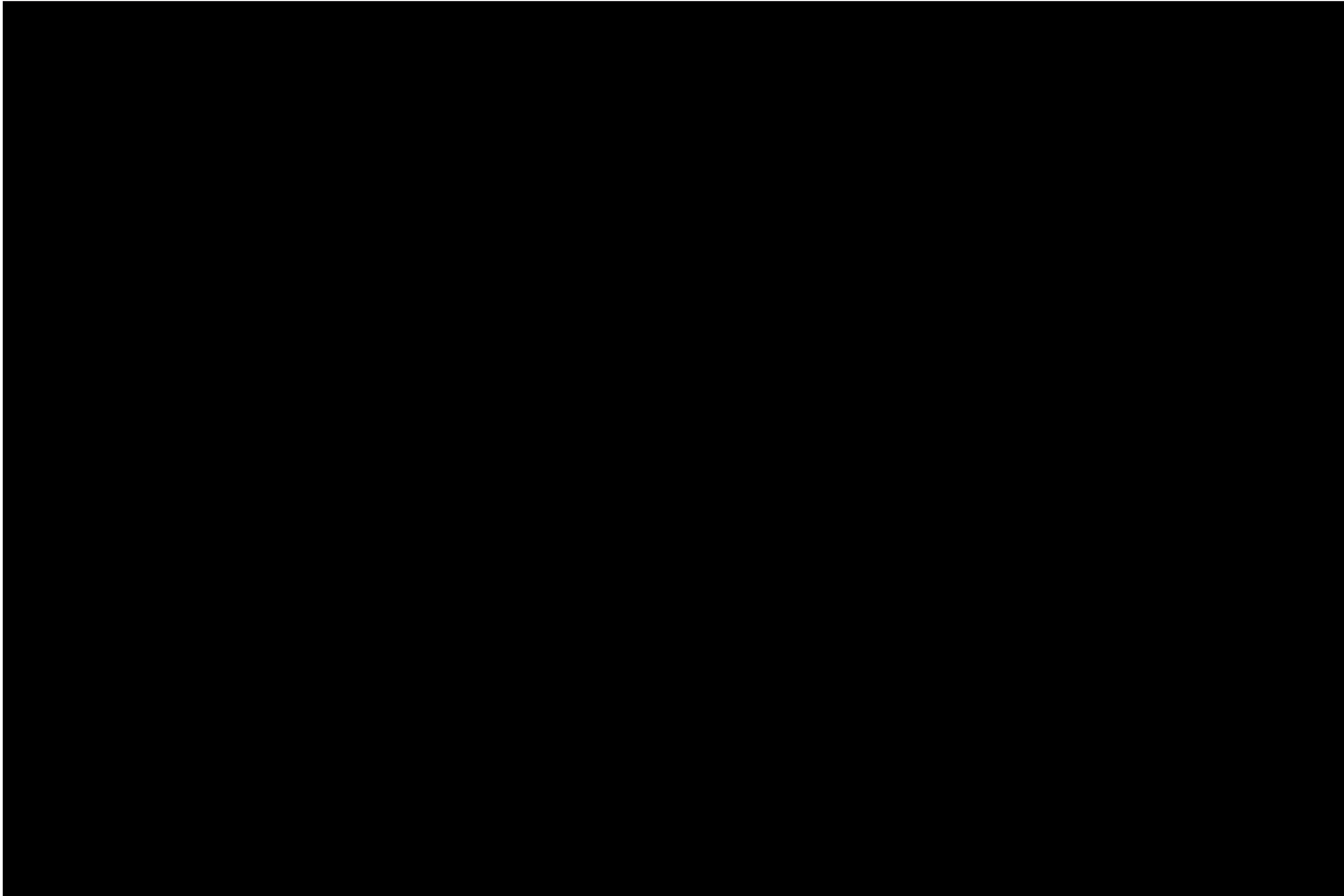


Photo 3











900 SW 70th Ave, Miami, FL 33144

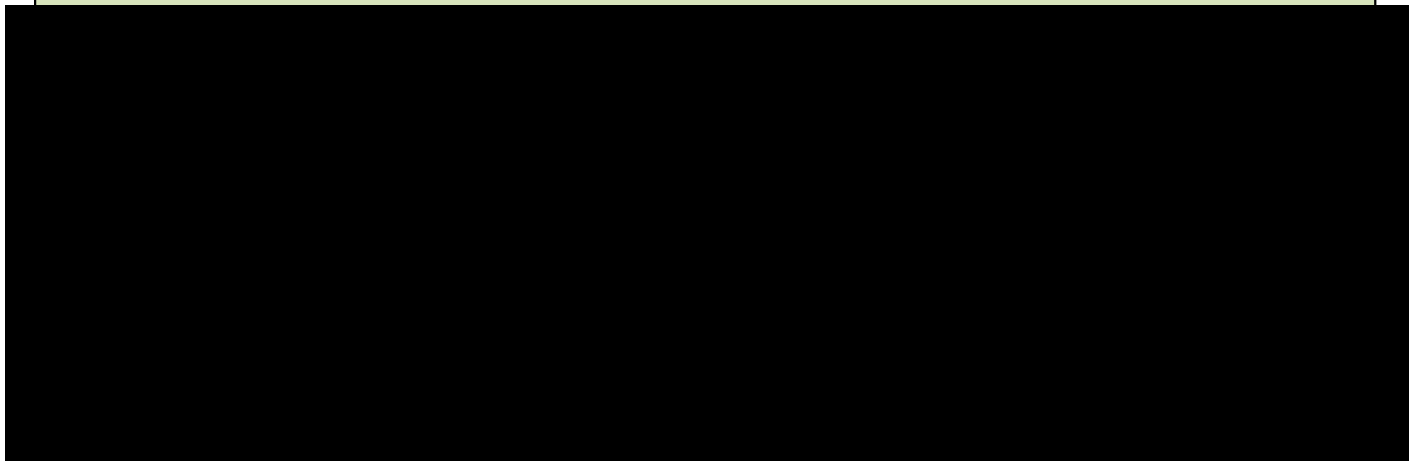
P:(305) 631-2578 F:(786) 615-5741

PCO #031

**PROPOSAL**

<b>Issue Date:</b>	October 29, 2025
<b>Project:</b>	Fort Lauderdale Police Headquarters & Parking Garage
<b>Project #:</b>	116
<b>Architect:</b>	AECOM
<b>Engineer:</b>	Thornton Tomasetti
<b>GC:</b>	Moss & Associates
<b>Ref:</b>	<b>DUMPSTER ENCLOSURE</b>

**Description of Work:** This proposal is for all additional costs associated with the Dumpster Enclosure of HQ at Level 1 requested by Mathew Kane of Moss & Associates via email dated 10/16/2025. Refer to the attached unit cost breakdown sheet and take-off for further further details.



Formwork Materials & Labor	Incl.
Concrete Materials	Incl.
Concrete Pumping, Placement & Finishing	Incl.
Reinforcement Materials & Labor	Incl.
Masonry	Incl.
Layout	Incl.
Hoisting	Incl.
Detailing	Incl.
Supervision	Incl.
Stripping & Cleanup	Incl.
Freight	Incl.
<b>Tax (7%)</b>	incl.
<b>Sub-total.</b>	incl.
<b>Overhead &amp; Profit</b>	incl.
<b>Total</b>	<b>\$ 78,323.00</b>

**Notes:**

1	Tekton Construction disclaims to the fullest extent authorized by law all warranties, whether expressed or implied, for the scope of work stated above.
---	---

**Disclaimer:** Tekton Construction reserves it's right to future claims in the event that is has omitted any work in relation to this proposal.

Thank you,

Usama Ahmed  
 900 Sw 70th Avenue  
 Miami, Florida 33144  
 P:305-631-2578 F:786-615-5741

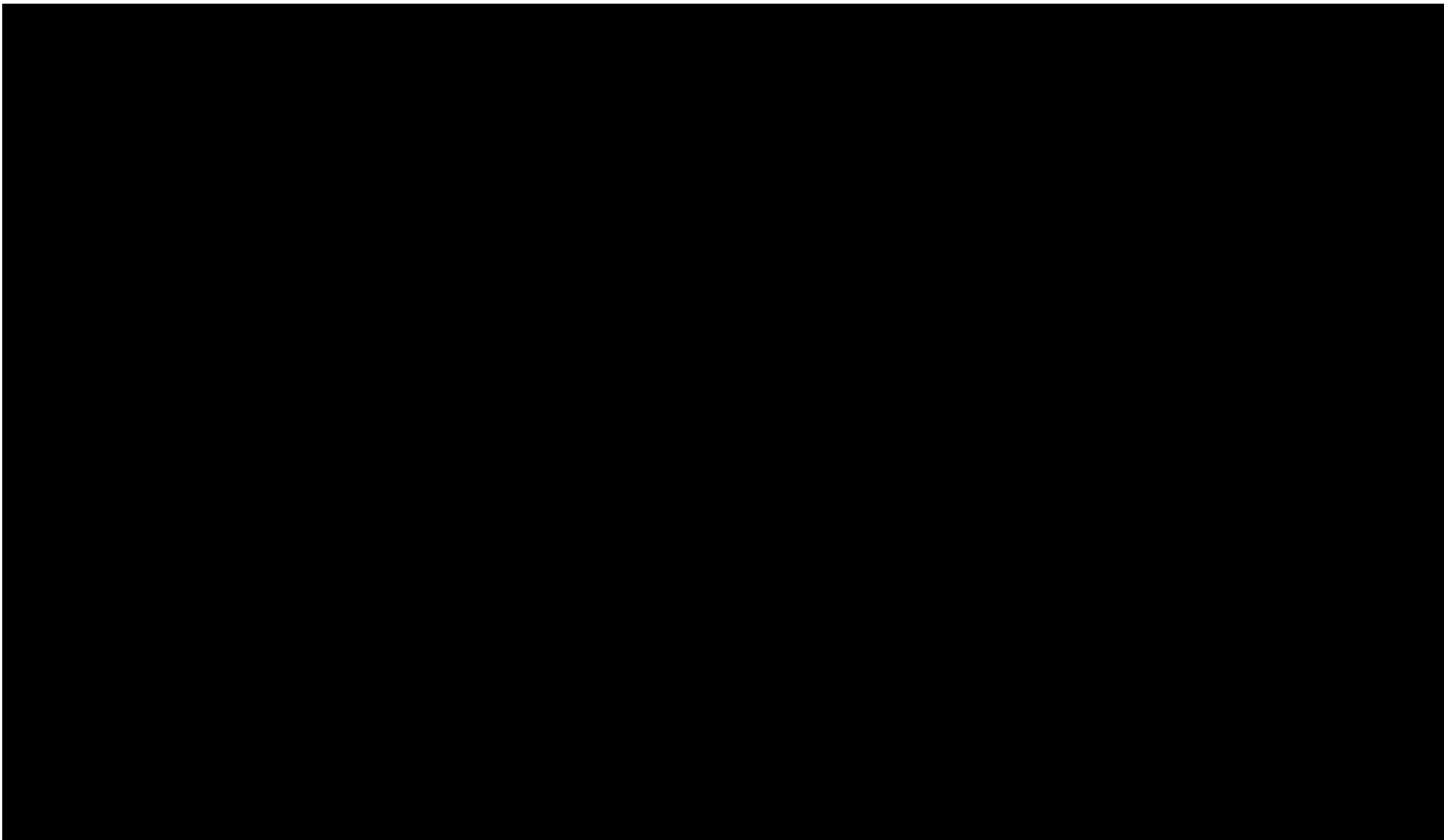


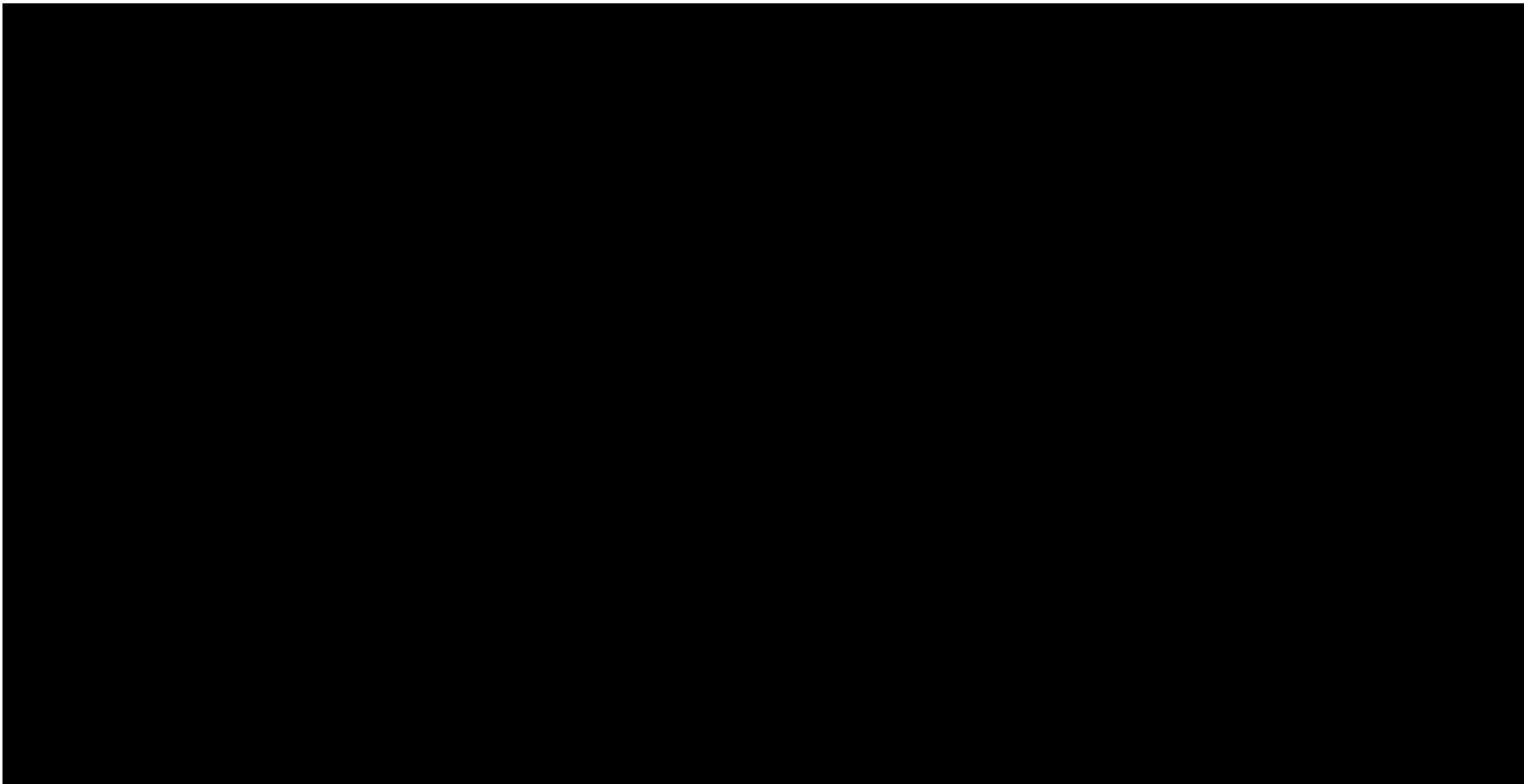
900 SW 70th Ave, Miami, FL 33144

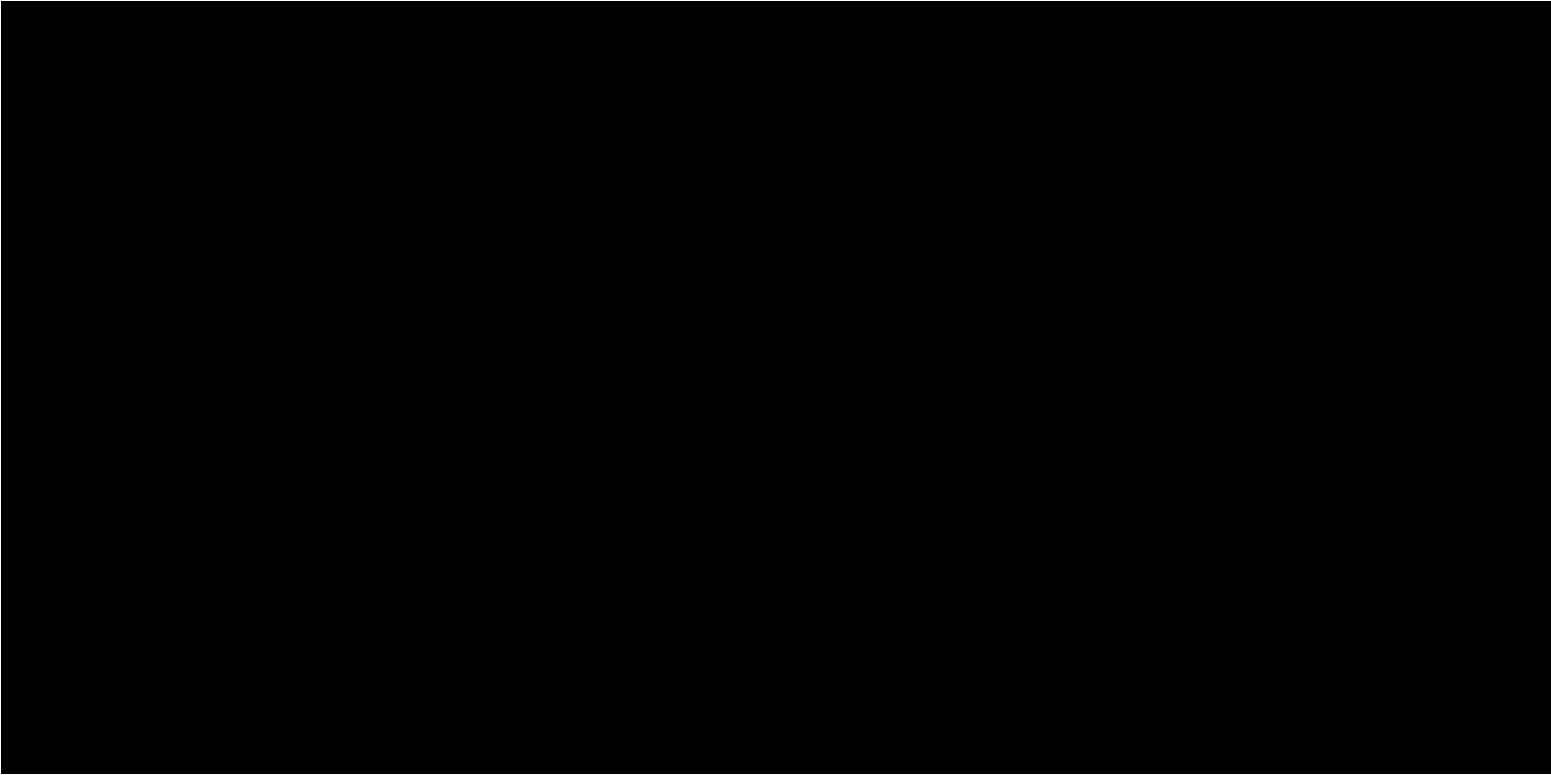
P:(305) 631-2578 F:(786) 615-5741

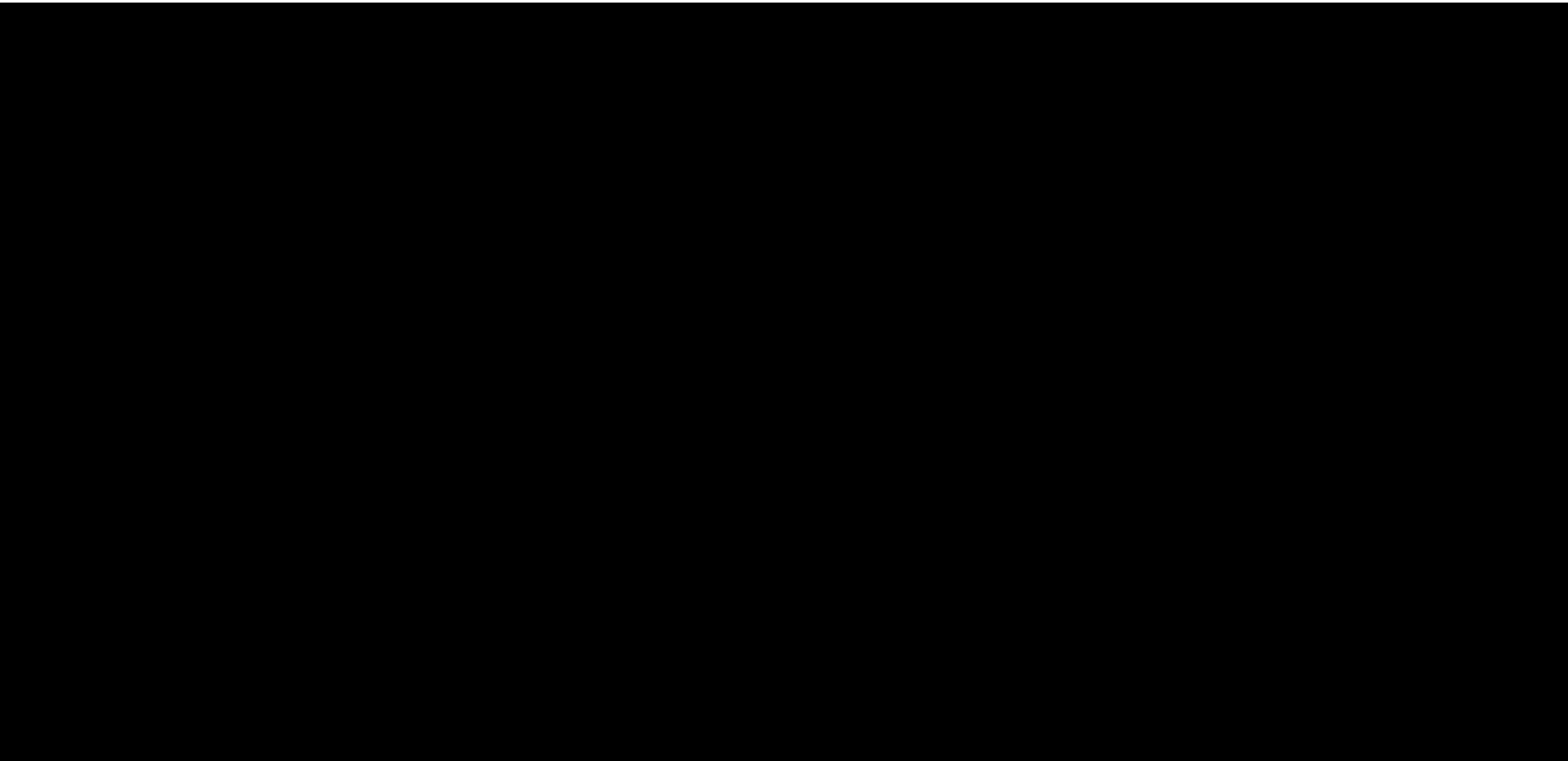
**HQ - DUMPSTER ENCLOSURE**

Description	\$ / Unit	Quantity	UOM	Price
<b>Formwork</b>				
Formwork Material - Footing, SOG & Conc Cap	\$ 6.00	838.11	C-Area	\$ 5,028.67
Formwork Labor- Footing, SOG & Conc Cap	\$ 10.00	838.11	C-Area	\$ 8,381.11
Formwork Labor - Strip & Cleanup - <i>4 Carpenters for 8 Hrs</i>	\$ 65.00	32.00	Hours	\$ 2,080.00
<b>Reinforcement</b>				
Rebar Materials - Footing, SOG, Conc Cap & CMU Wall	\$ 1,500.00	1.57	Tons	\$ 2,355.27
Rebar Labor - <i>4 Ironworkers for 8 Hrs for Footing / T.E &amp; SOG</i>	\$ 70.00	32.00	Hours	\$ 2,240.00
Rebar Labor - <i>2 Ironworkers for 6 Hrs for CMU &amp; Conc Cap</i>	\$ 70.00	12.00	Hours	\$ 840.00
Drill & Epoxy - Materials	\$ 2,500.00	1.00	LS	\$ 2,500.00
Drill & Epoxy - Labor - <i>4 Ironworkers for 8 Hrs</i>	\$ 70.00	32.00	Hours	\$ 2,240.00
<b>Concrete Materials, Pump &amp; Labor</b>				
Concrete Materials - 4 KSI @ 28 Days	\$ 219.00	29.11	Cubic-Yard	\$ 6,374.97
Concrete Pump ( <i>8hr min 2hr travel</i> ) - 2 Mobs	\$ 130.00	20	Per Day	\$ 2,600.00
Concrete Placement - <i>4 Laborers for 6 Hrs Per Mob x 2 Mobs</i>	\$ 45.00	48	hours	\$ 2,160.00
Concrete Finishing @ \$495 per Man up to 8 hrs	\$ 495.00	3	Men	\$ 1,485.00
Block Material & Labor	\$ 14.50	317.45	Each	\$ 4,603.02
<b>Misc.</b>				
Tekton Mobilization Fee	\$ 3,500.00	1	Lumpsum	\$ 3,500.00
Detailing	\$ 120.00	30	hours	\$ 3,600.00
Supervision	\$ 130.00	60	hours	\$ 7,800.00
Freight ( <i>For Additional Materials Stated Above</i> )	\$ 500.00	2	Lumpsum	\$ 1,000.00
Taxes (7%) ( <i>For Materials Only</i> )				\$ 1,460.33
Sub-Total				\$ 60,248.37
O.H. & Profit				\$ 18,074.51
<b>TOTAL</b>				<b>\$ 78,323</b>













900 SW 70th Ave, Miami, FL 33144

P:(305) 631-2578 F:(786) 615-5741

PCO #032

**PROPOSAL**

<b>Issue Date:</b>	April 9, 2026
<b>Project:</b>	Fort Lauderdale Police Headquarters & Parking Garage
<b>Project #:</b>	116
<b>Architect:</b>	AECOM
<b>Engineer:</b>	Thornton Tomasetti
<b>GC:</b>	Moss & Associates
<b>Ref:</b>	<b>Pour back SOG at Parking Garage</b>

**Description of Work:** This proposal is for all additional costs associated with Additional work for two areas on Ground Level requested by Moss & Associates resulting in costs impact to Tekton's scope of work. Refer to the attached unit cost breakdown sheet for further details.

<b>Scope of Work Included for Above Elements:</b>	
Formwork Materials & Labor	Incl.
Concrete Materials	Incl.
Reinforcement Materials & Labor	Incl.
Hoisting	Incl.
Supervision	Incl.
Stripping & Cleanup	Incl.
Freight	Incl.
<b>Tax (7%)</b>	incl.
<b>Sub-total.</b>	incl.
<b>Overhead &amp; Profit (10%).</b>	incl.

<b>Total</b>	<b>\$ 19,927</b>
--------------	------------------

**Notes:**

1	Tekton Construction will require an approval on this change order before proceeding with performing the extra to contract shown in this proposal.
---	---

**Disclaimer:** Tekton Construction reserves it's right to future claims in the event that is has omitted any work in relation to this proposal.

Thank you,

Sean Aleman  
 900 SW 70th Avenue.  
 Miami, FL 33144  
 P:305-631-2578 F:857-294-4980



900 SW 70th Ave, Miami, FL 33144  
 P:(305) 631-2578 F:(786) 615-5741

**PCO #032**

Description	\$ / Unit	Quantity	UOM	Price
-------------	-----------	----------	-----	-------

**Pour back SOG at Parking Garage**

<b>Ground Level</b>				
Description	\$ / Unit	Quantity	UOM	Price
Form Work Material ( <i>Vapor Barrier material</i> )	\$ 750.00	1	lumpsum	\$ 750.00
Form Work Labor ( <i>Installation of Vapor Barrier</i> )	\$ 1,250.00	1	lumpsum	\$ 1,250.00
Reinforcing Steel Materials	\$ 1,250.00	0.6	tons	\$ 750.00
Reinforcing Steel Labor - <i>2 Ironworkers for 10 hrs x 2 days</i>	\$ 70.00	40	hours	\$ 2,800.00
Drill & Epoxy Materials - <i>Materials (Epoxy + Gun)</i>	\$ 750.00	1	Lumpsum	\$ 750.00
Drill & Epoxy labor - <i>2 Labors by 8 hrs x 2 days</i>	\$ 45.00	32	hours	\$ 1,440.00
<b>Concrete Materials</b>				
Concrete Materials - 4 KSI @ 28 Days	\$ 250.00	5	Cy	\$ 1,250.00
Concrete Pump ( <i>8hr min 2hr travel</i> ) <i>1 MOB only</i>	\$ 130.00	10	hours	\$ 1,300.00
Concrete Placement - <i>4 Laborers @ 8 Hours</i>	\$ 45.00	32	hours	\$ 1,440.00
Finishers	\$ 500.00	4	men	\$ 2,000.00
Supervision	\$ 130.00	20	hours	\$ 2,600.00
Hoisting / Material Setup	\$ 130.00	8	hours	\$ 1,040.00
Freight ( <i>For Additional Materials Stated Above</i> )	\$ 500.00	1	Lumpsum	\$ 500.00
Taxes (7%) ( <i>For Materials Only</i> )				\$ 245.00
Sub-Total				\$ 18,115.00
O.H. & Profit (10%)				\$ 1,811.50
<b>TOTAL</b>				<b>\$ 19,927</b>
<b>Total \$</b>				<b>19,927</b>



CFC057223

## REQUEST FOR CHANGE ORDER

PROJECT NAME	Fort Lauderdale Police Headquarters and Parking Garage		
LOCATION OF WORK	1300 W Broward Blvd. Fort Lauderdale, FL 33312		
CONTRACT NO.		RCO#	RCO#18
REQUESTED BY	MOSS	DATE OF REQUEST	12/15/25
PROJECT MANAGER	Rick Doucette	SUB-CONTRACTOR	A Better Plumbing
OWNER		ENGINEER	

### SCOPE OF WORK

This Change Order is to add a hose bib for the newly added trash area. Please see attached material, labor, and contract documents showing the work to be completed.

Total Man Hours: 80 Man Hours 2 Plumbers

Total Man Hours: Operator for Excavation 2 days, one day to dig, one day to backfill 16 total hours

### SUBCONTRACTOR ITEMIZED BREAKDOWN OF MATERIAL

Materials	DESCRIPTION	QUANTITY	UNIT PRICE	AMOUNT
	Rough Materials			\$1,614.14
	Core Drill Costs			\$500.00
	Excavator Machine Costs			\$1,950.00
			TOTAL	\$4,064.14

LABOR	NO. OF HRS	RATE	AMOUNT
JOURNEYMAN RATE	96	\$95.00	\$9,120.00
<b>TOTAL</b>			\$9,120.00
EQUIPMENT	NO. OF HRS	RATE	AMOUNT
RENTED			
OWNED			
TRUCKING			
<b>TOTAL</b>			\$13,184.14
<b>OVERHEAD (MATERIAL, LABOR, &amp; EQUIPMENT TOTAL)</b>		x 10%	\$1,318.41
<b>GRAND TOTAL</b>			<b>\$14,502.55</b>

<b>RECOMMENDED BY</b> ENGINEER OF RECORD		<b>APPROVED BY</b> OWNER	
<b>DATE</b>		<b>DATE</b>	
<b>ACCEPTED BY</b> CONTRACTOR		<b>REVIEWED BY</b> FUNDER	
<b>DATE</b>		<b>DATE</b>	



FERGUSON ENTERPRISES LLC #140  
 9439 WEST COMMERCIAL BLVD  
 TAMARAC, FL 33351-4321

Phone: 954-726-3951  
 Fax: 954-720-1554

Deliver To: CELL 954-520-4500  
 From: Kyle Wilder  
 kyle.wilder@ferguson.com

Comments:

14:20:12 DEC 15 2025

Page 1 of 2

FERGUSON ENTERPRISES LLC #52

Price Quotation  
 Phone: 954-726-3951  
 Fax: 954-720-1554

**Bid No:** B684115  
**Bid Date:** 12/15/25  
**Quoted By:** KBW

**Cust Phone:** 954-421-2226  
**Terms:** 2% 10TH NET 25TH

**Customer:** A BETTER INC  
 4061 NORTH FEDERAL HWY  
 FT LAUD POLICE HEADQUART  
 POMPANO BEACH, FL 33064

**Ship To:** A BETTER INC  
 4061 NORTH FEDERAL HWY  
 FT LAUD POLICE HEADQUART  
 POMPANO BEACH, FL 33064

**Cust PO#:**

**Job Name:** FT. LAUD POLICE HEADQUART

Item	Description	Quantity	Net Price	UM	Total
	***** *****				
	----				
FNW5V3376KKG	*TRN LF 2X2X1 PXPXP TEE	1	75.575	EA	75.58
FNW5V0576K	LF 2 PXP COUP L/ ST	2	31.444	EA	62.89
LHARDG20	1 X 20 L HARD COP TUBE	40	764.626	C	305.85
FNW7001ECG	1 EPOX COP SPLT RNG HGR 3/8	8	2.706	EA	21.65
FNW5V1276G	LF 1 PXP SR 90 ELL	8	10.561	EA	84.49
LSOFTG60	1 X 60 L SOFT COP TUBE	60	1295.502	C	777.30
O38707	BLUE 200 FT PIPE GUARD SLV	1	27.525	EA	27.53
FNW5V4976GF	LF 1X3/4 PXP RED	1	15.800	EA	15.80
FNWX432G	LF 1 BRS PXP FP BV WTR	2	35.213	EA	70.43
FNW5V0076F	LF 3/4X3/4 BRS PXM ADPT	1	6.800	EA	6.80
LHARDF10	3/4 X 10 L HARD COP TUBE	10	520.126	C	52.01
PFX76FC	LFN 3/4 BRS FIP X HOSE BLR DRN	1	8.210	EA	8.21

**Net Total:** \$1508.54  
**Tax:** \$105.60  
**Freight:** \$0.00  
**Total:** \$1614.14



**HOW ARE WE DOING? WE WANT YOUR FEEDBACK!**

Scan the QR code or use the link below to  
 complete a survey about your bids:

<https://survey.medallia.com/?bidsorder&fc=140&on=775562>

CAM #26-0510

Exhibit 3

Page 30 of 262

14:20:12 DEC 15 2025

**Reference No:** B684115

Quoted prices are based upon receipt of the total quantity for immediate shipment (48 hours). SHIPMENTS BEYOND 48 HOURS SHALL BE AT THE PRICE IN EFFECT AT TIME OF SHIPMENT UNLESS NOTED OTHERWISE. QUOTES FOR PRODUCTS SHIPPED FOR RESALE ARE NOT FIRM UNLESS NOTED OTHERWISE.

Due to the uncertain impact of potential tariffs, Ferguson's quotation/proposal has not included any provision or contingency for future tariffs or increase of existing tariffs. Ferguson reserves the right to adjust prices to reflect the impact of any new or increased tariffs that affect our costs at the time of shipment. Ferguson will provide notice of any such adjustments along with documentation supporting the changes.

CONTRACTOR CUSTOMERS: IF YOU HAVE DBE/MBE/WBE//VBE/SDVBE/SBE GOOD FAITH EFFORTS DIVERSITY GOALS/ REQUIREMENTS ON A FEDERAL, STATE, LOCAL GOVERNMENT, PRIVATE SECTOR PROJECT, PLEASE CONTACT YOUR BRANCH SALES REPRESENTATIVE IMMEDIATELY PRIOR TO RECEIVING A QUOTE/ORDER.

Seller not responsible for delays, lack of product or increase of pricing due to causes beyond our control, and/or based upon Local, State and Federal laws governing type of products that can be sold or put into commerce. This Quote is offered contingent upon the Buyer's acceptance of Seller's terms and conditions, which are incorporated by reference and found either following this document, or on the web at <https://www.ferguson.com/content/website-info/terms-of-sale>

Govt Buyers: All items are open market unless noted otherwise.

LEAD LAW WARNING: It is illegal to install products that are not "lead free" in accordance with US Federal or other applicable law in potable water systems anticipated for human consumption. Products with \*NP in the description are NOT lead free and can only be installed in non-potable applications. Buyer is solely responsible for product selection.

Buyer shall accept delivery of products within 60 days of Seller receiving the products at Seller's warehouse. If Buyer causes or requests a delay in delivery of the products, Buyer may be subject to storage fees and additional costs caused by such delay. Seller reserves the right to requote the products and reschedule the delivery date, subject to manufacturer's lead times and price increases, if Buyer is unable to accept delivery within 60 days.

**HOW ARE WE DOING? WE WANT YOUR FEEDBACK!**

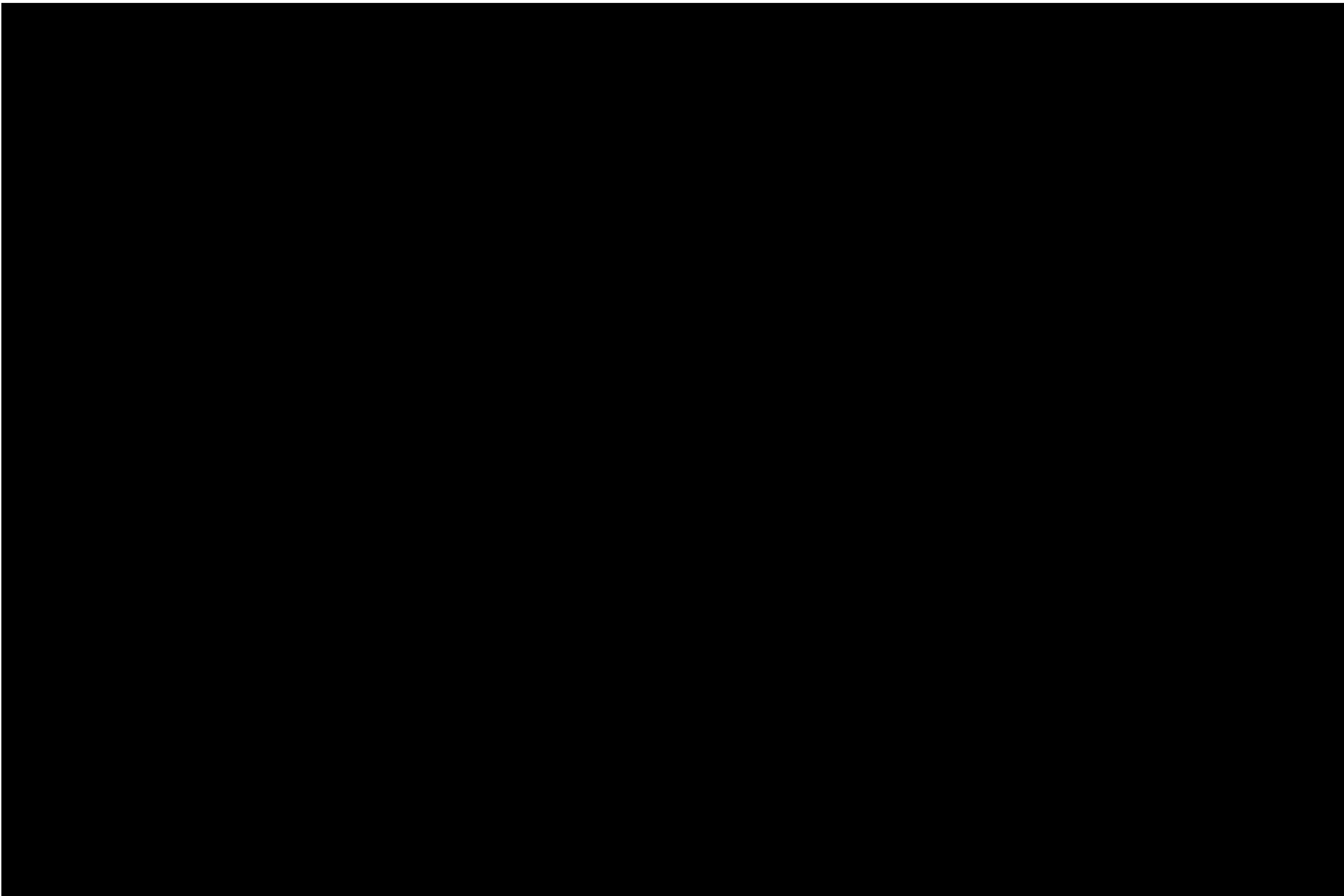
Scan the QR code or use the link below to  
complete a survey about your bids:

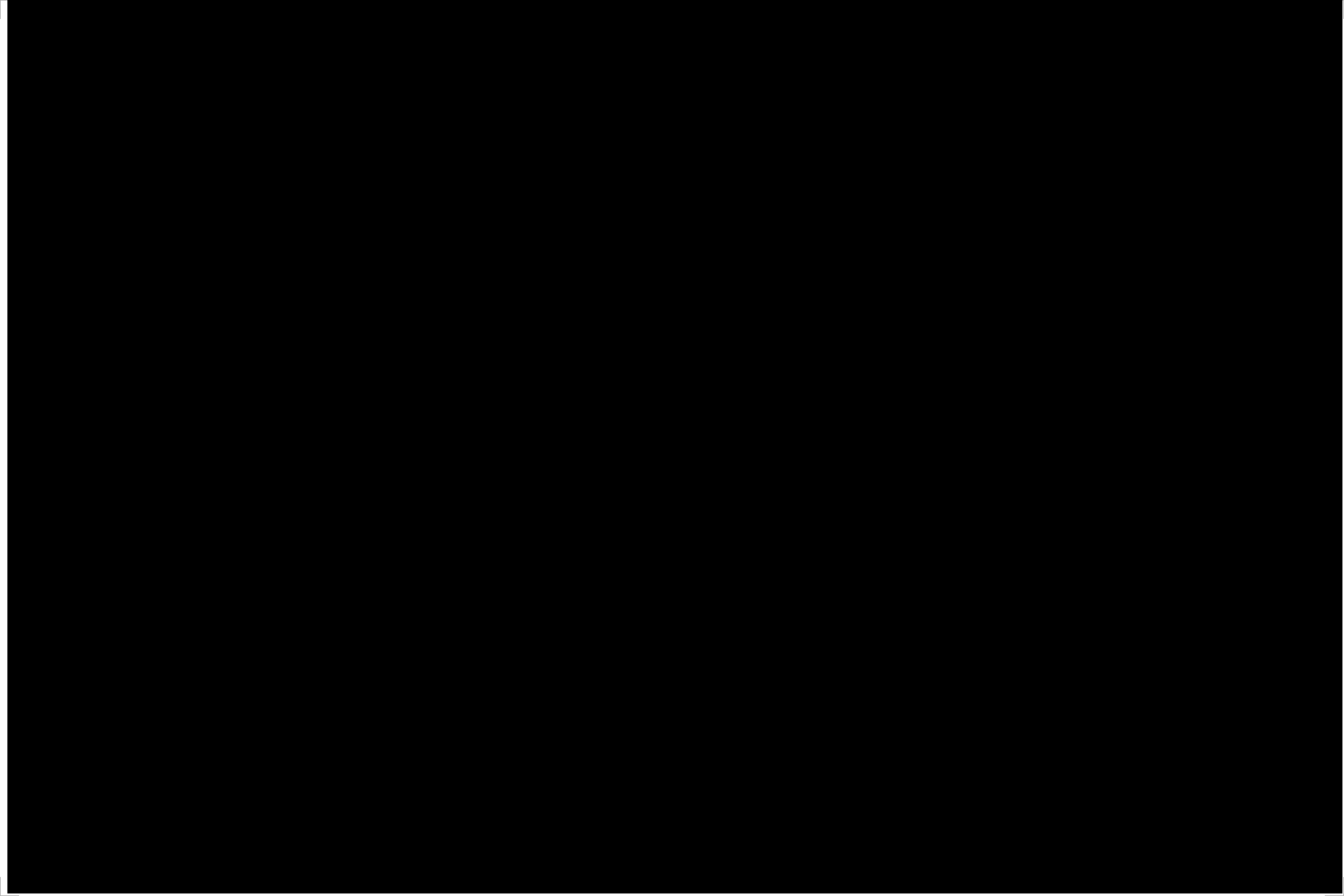
<https://survey.medallia.com/?bidsorder&fc=140&on=775562>

CAM #26-0510

Exhibit 3

Page 31 of 262







CFC057223

## REQUEST FOR CHANGE ORDER

PROJECT NAME	Fort Lauderdale Police Headquarters and Parking Garage		
LOCATION OF WORK	1300 W Broward Blvd. Fort Lauderdale, FL 33312		
CONTRACT NO.		RCO#	RCO# 19 Revised
REQUESTED BY	MOSS	DATE OF REQUEST	3/31/26
PROJECT MANAGER	Rick Doucette	SUB-CONTRACTOR	A Better Plumbing
OWNER		ENGINEER	

### SCOPE OF WORK

RCO# 19 Revised is to install two Dumpster Drains per the attached contract documents and tie in to the existing sanitary system inside the parking garage. Quote includes slab cutting, removal, excavation, and backfill. This does not include any concrete or asphalt pour back or repairs.

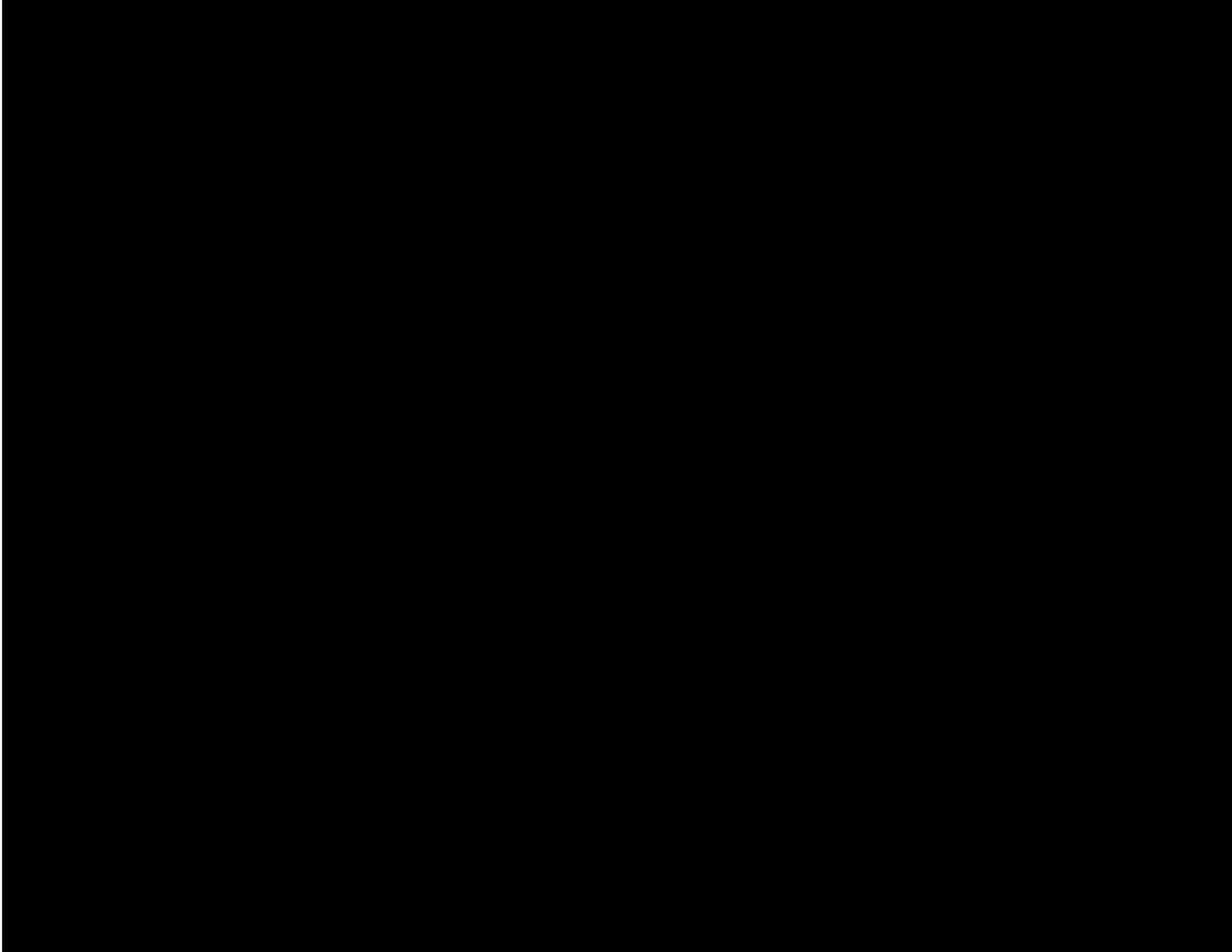
Total Man Hours: 120 Man Hours: 3 plumbers 5 working days.

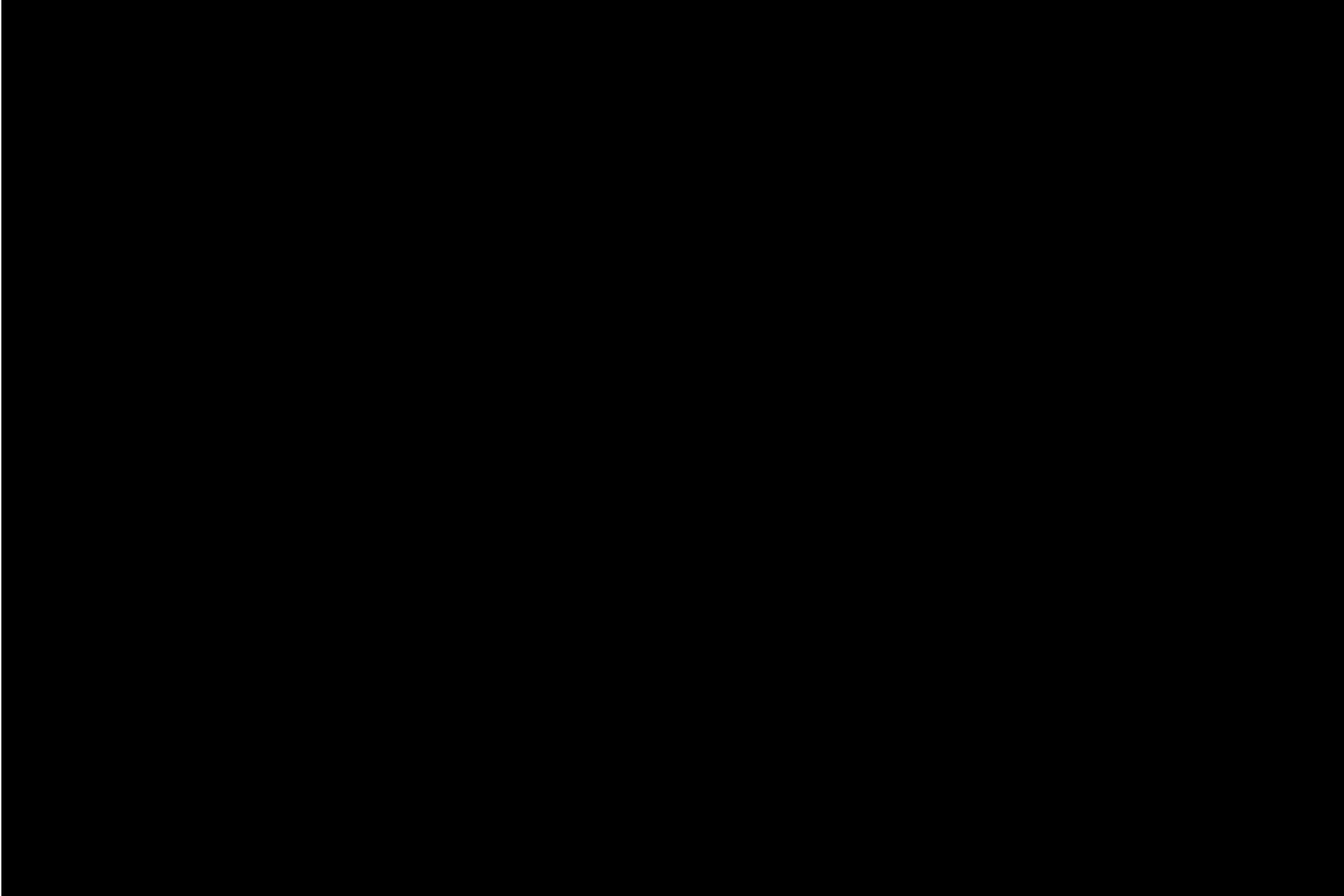
### SUBCONTRACTOR ITEMIZED BREAKDOWN OF MATERIAL

Materials	DESCRIPTION	QUANTITY	UNIT PRICE	AMOUNT
	Rough Materials Including Interceptor			\$9,941.92
	Concrete Cut/Removal and Excavation			\$10,250.00
			TOTAL	\$20,191.92

LABOR	NO. OF HRS	RATE	AMOUNT
JOURNEYMAN RATE	120	\$95.00	\$11,400.00
<b>TOTAL</b>			\$11,400.00
EQUIPMENT	NO. OF HRS	RATE	AMOUNT
RENTED			
OWNED			
TRUCKING			
<b>TOTAL</b>			\$31,591.92
<b>OVERHEAD (MATERIAL, LABOR, &amp; EQUIPMENT TOTAL)</b>		x 10%	\$3,159.19
<b>GRAND TOTAL</b>			<b>\$34,751.11</b>

<b>RECOMMENDED BY</b> ENGINEER OF RECORD		<b>APPROVED BY</b> OWNER	
<b>DATE</b>		<b>DATE</b>	
<b>ACCEPTED BY</b> CONTRACTOR		<b>REVIEWED BY</b> FUNDER	
<b>DATE</b>		<b>DATE</b>	









DIRTWORK SOLUTIONS  
 (561) 374-3639  
 15276 HARRISON RD  
 Delray Beach, FL 33484

**Prepared For**  
 Bill Fusco  
 A BETTER, INC.  
 4061 N. FEDERAL HIGHWAY  
 POMPANO BEACH, FL 33064

**Proposal Date**  
 03/30/2026

**Proposal Number**  
 000000188

**Reference**  
 FT.Lauderdale Police

## Pricing

Description	Rate	Qty	Line Total
Concrete & Site work See notes for scope of work	\$10,250.00	1	\$10,250.00
Subtotal			10,250.00
Tax			0.00
<b>Proposal Total (USD)</b>			<b>\$10,250.00</b>

## Notes

Site Work  
 Concrete Cutting & Removal  
 Parking Garage  
 6'x 6' x 6"-8"slab  
 34' x 3' x 6"-8" Slab  
 Asphalt cutting & Removal  
 Approximately 600 Sq ft 2.5" Asphalt

Excavate and backfill for new sewer line and grease trap.  
 Approximately 80'  
 6'x6' x3' -5' to find existing sewer line  
 10' x 10' x 4' for grease trap  
 Haul away any excess fill



FERGUSON ENTERPRISES LLC #140  
 9439 WEST COMMERCIAL BLVD  
 TAMARAC, FL 33351-4321

Phone: 954-726-3951  
 Fax: 954-720-1554

Deliver To: CELL 954-520-4500  
 From: Kyle Wilder  
 kyle.wilder@ferguson.com

Comments:

10:50:21 MAR 31 2026

Page 1 of 2

FERGUSON ENTERPRISES LLC #52

Price Quotation

Phone: 954-726-3951

Fax: 954-720-1554

**Bid No:** B082789  
**Bid Date:** 03/31/26  
**Quoted By:** KBW

**Cust Phone:** 954-421-2226  
**Terms:** 2% 10TH NET 25TH

**Customer:** A BETTER INC  
 4061 NORTH FEDERAL HWY  
 FT LAUD POLICE HEADQUART  
 POMPANO BEACH, FL 33064

**Ship To:** A BETTER INC  
 4061 NORTH FEDERAL HWY  
 FT LAUD POLICE HEADQUART  
 POMPANO BEACH, FL 33064

**Cust PO#:**

**Job Name:** FLPH DUMPSTER ADD

Item	Description	Quantity	Net Price	UM	Total
SP-SOS50SS	OS-50 HIGH EFFICIENCY OIL/WATER SEP	1	7280.000	EA	7280.00
S2233LXH04	*CVR* 4 LXH 2233	1	414.750	EA	414.75
P40PP20	4X20 FT PVC DWV S40 PE PIPE	100	169.612	C	169.61
PDWVCOMBTPUUP	6X6X4 PVC DWV COMB	1	61.500	EA	61.50
F105666	6 CI PVC X 6 CI PVC COUP	2	17.000	EA	34.00
FSRC25	6 SHEAR RNG F/ 1056-55	2	25.675	EA	51.35
P40PU20	6X20 FT PVC DWV S40 PE PIPE	20	318.437	C	63.69
F105644	4 CI PVC X 4 CI PVC COUP	2	7.956	EA	15.91
FSRC19	4 SHEAR RNG F/ 1056-44 1055-44	2	19.500	EA	39.00
PDWVCP	4 PVC DWV COUP	4	2.966	EA	11.86
PDWV4P	4 PVC DWV 45 ELL	12	5.896	EA	70.75
PDWVCOMBP	4 PVC DWV COMB	2	17.762	EA	35.52
PDWVPTP	4 PVC DWV P TRAP	2	28.494	EA	56.99
PDWVCOMBPPK	4X4X2 PVC DWV COMB	1	9.275	EA	9.28
P40PK20	2X20 FT PVC DWV S40 PE PIPE	40	62.250	C	24.90
PDWV4K	2 PVC DWV 45 ELL	4	1.131	EA	4.52
PFAAV20	160 BR/72 STK AAV 1.5-2 PVC ADPT	1	24.712	EA	24.71
O31118	1 GAL PVC HD GRAY CMNT	1	76.262	EA	76.26
O30759	1 GAL PURP PRMR - NSF LISTED	1	41.200	EA	41.20
O31276	12 IN GAL CAN SWAB APPLICATOR	2	30.512	EA	61.02
O31257	RED. BRSH TOP F/ QT CAN	2	5.469	EA	10.94
O31307	EMPTY QT CMNT CAN	2	6.606	EA	13.21
PSDTC260B	2X60 DUCT TAPE PREM GRD BLK	1	14.312	EA	14.31
PDWVLS9P	4 PVC DWV LS 90 ELL	1	8.725	EA	8.73
ZZN14004NL	FLR C/O NB TOP 4 NL ADJ LEV TROL FLR CO W/NB TOP	1	256.725	EA	256.73
ZZ5204NL	DUMPSTER DRN *CVR* 9" DIA ADJUSTABLE HD DRN	2	240.630	EA	481.26

**Net Total:** \$9332.00  
**Tax:** \$609.92  
**Freight:** \$0.00  
**Total:** \$9941.92



**HOW ARE WE DOING? WE WANT YOUR FEEDBACK!**

Scan the QR code or use the link below to  
 complete a survey about your bids:

<https://survey.medallia.com/?bidsorder&fc=140&on=775562>

CAM #26-0510

Exhibit 3

Page 40 of 262

10:50:21 MAR 31 2026

**Reference No:** B082789

Quoted prices are based upon receipt of the total quantity for immediate shipment (48 hours). SHIPMENTS BEYOND 48 HOURS SHALL BE AT THE PRICE IN EFFECT AT TIME OF SHIPMENT UNLESS NOTED OTHERWISE. QUOTES FOR PRODUCTS SHIPPED FOR RESALE ARE NOT FIRM UNLESS NOTED OTHERWISE.

Due to the uncertain impact of potential tariffs, Ferguson's quotation/proposal has not included any provision or contingency for future tariffs or increase of existing tariffs. Ferguson reserves the right to adjust prices to reflect the impact of any new or increased tariffs that affect our costs at the time of shipment. Ferguson will provide notice of any such adjustments along with documentation supporting the changes.

CONTRACTOR CUSTOMERS: IF YOU HAVE DBE/MBE/WBE//VBE/SDVBE/SBE GOOD FAITH EFFORTS DIVERSITY GOALS/ REQUIREMENTS ON A FEDERAL, STATE, LOCAL GOVERNMENT, PRIVATE SECTOR PROJECT, PLEASE CONTACT YOUR BRANCH SALES REPRESENTATIVE IMMEDIATELY PRIOR TO RECEIVING A QUOTE/ORDER.

Seller not responsible for delays, lack of product or increase of pricing due to causes beyond our control, and/or based upon Local, State and Federal laws governing type of products that can be sold or put into commerce. This Quote is offered contingent upon the Buyer's acceptance of Seller's terms and conditions, which are incorporated by reference and found either following this document, or on the web at <https://www.ferguson.com/content/website-info/terms-of-sale>

Govt Buyers: All items are open market unless noted otherwise.

LEAD LAW WARNING: It is illegal to install products that are not "lead free" in accordance with US Federal or other applicable law in potable water systems anticipated for human consumption. Products with \*NP in the description are NOT lead free and can only be installed in non-potable applications. Buyer is solely responsible for product selection.

Buyer shall accept delivery of products within 60 days of Seller receiving the products at Seller's warehouse. If Buyer causes or requests a delay in delivery of the products, Buyer may be subject to storage fees and additional costs caused by such delay. Seller reserves the right to requote the products and reschedule the delivery date, subject to manufacturer's lead times and price increases, if Buyer is unable to accept delivery within 60 days.

**HOW ARE WE DOING? WE WANT YOUR FEEDBACK!**

Scan the QR code or use the link below to  
complete a survey about your bids:

<https://survey.medallia.com/?bidsorder&fc=140&on=775562>

CAM #26-0510

Exhibit 3

Page 41 of 262



**EMM - TRACE INC.**

5791 Nw 37th ave.  
 HIALEAH, FL. 33142  
 Phone (305) - 684 - 7172  
[WWW.EMM-TRACE.COM](http://WWW.EMM-TRACE.COM)

**CHANGE ORDER**

<b>CUSTOMER</b>	MOSS & ASSOCIATES	<b>C.O.</b>	<b>Nº</b>	007
<b>PHONE</b>	954.524.56.78	<b>DATE</b>	3/5/26	
<b>CONTACT</b>	Matthew Kane	<b>VALID UNTIL</b>	4/19/26	
<b>E-MAIL</b>	<a href="mailto:mkane@moss.com">mkane@moss.com</a>	<b>TERMS</b>	3	WEEKS
<b>JOB</b>	Police Department Headquarters		AFTER APPROVED PLANS AND FINAL MEASURES ARE TAKEN	
<b>ADDRESS</b>	1300 W Broward Blvd FT Lauderdale, FL 33312	<b>SHIPPING</b>	INCLUDED	

ITEM	QTY.	UNIT	DESCRIPTION	PRICE	TOTAL
1	1	PCS.	20'-1" W. - 7'-0" H Dumpster Double Gate - Galvanized Steel Material: HSS 4x4 and framing, Aluminum Louver blades for gate infill. Includes: Hardware and heavy duty hinges, standard lock system. Excludes: Any reinforcement to substrate for the post installation.		
<b>MATERIAL :</b>					<b>\$ 9,875.54</b>
			ALUMINUM SQUARE TUBE 4" X 4" (GATE FRAMING)	4 PCS.	\$ 2,024.58
			ALUMINUM CHANNEL 4" X 1" (LOUVER FRAMING)	4 PCS.	\$ 1,125.60
			ALUMINUM LOUVER BLADES	60 PCS.	\$ 4,589.35
			ADDITIONAL ALUMINUM MATERIAL (CAPS, HANDLE, FLAT BARS)		\$ 789.56
			HARDWARE (ANCHORS, HEAVY DUTY HINGES)		\$ 1,346.45
			<b>LABOR : FABRICATION (3 PPL)</b>	96 HRS	<b>\$ 3,260.50</b>
			<b>LABOR INSTALLATION (3 PPL)</b>	72 HRS	<b>\$ 2,690.50</b>
			<b>PAINT</b>		<b>\$ 5,128.33</b>
			<b>OVERHEAD AND PROFIT (10%)</b>		<b>\$ 2,150.80</b>

<b>Tax (7%)</b>	INCLUDED
<b>Bond (2%)</b>	N/A
<b>TOTAL</b>	<b>\$ 23,105.67</b>

Accepted by \_\_\_\_\_ Signature \_\_\_\_\_ Date \_\_\_\_\_

The signature of this proposal indicates the fully acceptance of all terms and conditions mentioned above.

**DISCLAIMER**

This Change Order is an owner GC generated C.O., as such will impact the estimated time needed to complete the task. Between this date completion of Our estimate for and approval of C.O., no work can be done (signed and sealed drawings, fabricating, painting, or installation). Once a decision is (signed C.O., or email) made the process by owner or GC, only then can the process be restarted.



RFI#  
**Project Name:** FLPD  
**Project Number:** 23-414  
**Page Number:** 1  
**Change Order #:** 72  
**Change Order Date:** 12/19/2025

**Moss**  
 2101 N ANDREWS AVE  
 FT LAUDERDALE, FL 33311  
 Telephone: (954) 524-5678

**Scope of work**

At the request of ownership, this change order proposal is for the labor and material associated with SI-006 changes. These changes include the addition of light fixtures at the dumpster enclosure and modifications to the electrical provisions for the entrance gates. The proposal considers the conduit, wire, breakers, disconnects, etc. needed to implement the changes reflected in the revision.

Please note, in efforts to provide savings to owner we are using existing conduit provisions for the south gate to feed the new disconnect in the green area by the parking spaces. We are then branching to the gate.

This proposal also includes the quote to furnish the (3) W1 fixtures at the dumpster enclosure. The lights will be furnished with integral photocells for operation of the fixture in lieu of adding costs by extending lighting control. Circuit connected to spare breaker in Panel HG1D.

Please see attached for reference.

**Summary**

**MATERIAL**

General Materials		9,620.02	
WORLD ELECTRIC - Lighting		1,950.00	
Material Tax	(@ 7.000 %)	809.90	
			<b>12,379.92</b>

**Material Total**

**LABOR**

ELECTRICIAN	(164.32 Hrs @ \$55.00)	9,037.60	
FOREMAN	(41.08 Hrs @ \$65.00)	2,670.20	
SUPERINTENDENT	(16.43 Hrs @ \$70.00)	1,150.10	
PROJECT MANAGER	(4.93 Hrs @ \$85.00)	419.05	
BIM COORDINATION	(4.93 Hrs @ \$55.00)	271.15	
ESTIMATING	(4.00 Hrs @ \$55.00)	220.00	
			<b>13,768.10</b>

**Total Labor**

**EQUIPMENT**

BACKHOE RENTAL		1,161.98	
			<b>1,161.98</b>

**Total Equipment**

<b>TOTAL MATERIAL, LABOR &amp; EQUIPMENT</b>			<b>27,310.00</b>
--	--	--	------------------



**RFI#**  
**Project Name:** FLPD  
**Project Number:** 23-414  
**Page Number:** 2  
**Change Order #:** 72  
**Change Order Date:** 12/19/2025

**Moss**  
2101 N ANDREWS AVE  
FT LAUDERDALE, FL 33311  
Telephone: (954) 524-5678

---

**Summary (Cont'd)**

---

OH&P	(@ 10.000 %)	2,731.00
<b>Final Amount</b>		<b>\$30,041.00</b>



**Moss**  
 2101 N ANDREWS AVE  
 FT LAUDERDALE, FL 33311  
 Telephone: (954) 524-5678

**Project Name:** FLPD  
**Project Number:** 23-414  
**Page Number:** 3  
**Change Order #:** 72  
**Change Order Date:** 12/19/2025

**Itemized Breakdown**

Description	Qty	Net Price U	Total Mat.	Labor U	Total Hrs.
EXCAVATION (CUBIC YARD)	6	0.00 E	0.00	0.30 E	1.80
BACKFILL (CUBIC YARD)	6	0.00 E	0.00	0.30 E	1.80
COMPACTION (LINEAR FOOT)	148	0.00 E	0.00	0.02 E	2.96
1" DIAM CORE 6" THICK WALL	2	0.00 E	0.00	1.00 E	2.00
2" DIAM CORE 6" THICK WALL	2	0.00 E	0.00	0.00 E	0.00
FIRESTOP COMPOUND CAULK (1) PIPE	6	1.00 E	6.00	0.06 E	0.36
3/4" CONDUIT - EMT	111	154.78 C	171.81	4.40 C	4.88
1 1/4" CONDUIT - EMT	455	406.92 C	1,851.49	6.60 C	30.03
3/4" COUPLING COMP DC - EMT	9	244.48 C	22.00	0.00 C	0.00
3/4" CONN COMP DC INSUL - EMT	4	281.18 C	11.25	15.63 C	0.63
3/4" COUPLING COMP STL - EMT	2	424.55 C	8.49	37.50 C	0.75
1 1/4" COUPLING COMP STL - EMT	45	1,174.47 C	528.51	50.00 C	22.50
3/4" CONN COMP STL INSUL - EMT	10	471.66 C	47.17	15.63 C	1.56
1 1/4" CONN COMP STL INSUL - EMT	4	1,358.38 C	54.34	21.88 C	0.88
3/4" TYPE LB STD CONDUIT BODY - EMT - ALUM	1	20.89 E	20.89	0.56 E	0.56
3/4" CONDUIT BODY COVER - EMT	1	5.11 E	5.11	0.00 E	0.00
3/4" CONDUIT BODY NEOPRENE GASKET - EMT	1	3.04 E	3.04	0.06 E	0.06
3/4" LOCKNUT - STEEL	14	51.00 C	7.14	2.88 C	0.40
1 1/4" LOCKNUT - STEEL	2	131.31 C	2.63	5.81 C	0.12
1 1/4" BUSHING - PLASTIC	2	67.87 C	1.36	4.88 C	0.10
3/4" 1-H STRAP - EMT - STEEL	6	51.58 C	3.09	6.75 C	0.41
1 1/4" EMT & 1" RMC 1-PC STRUT CLAMP W/ SADDLE -	46	174.68 C	80.35	8.25 C	3.79
1/2 OR 3/4" CONDUIT SNAP CLOSE CLIP W/ 1/4-20 THRD	10	52.18 C	5.22	7.13 C	0.71
3/4" CONDUIT - PVC40	197	44.33 C	87.33	4.50 C	8.87
1 1/4" CONDUIT - PVC40	54	106.79 C	57.67	6.63 C	3.58
3/4" ELBOW 90 DEG - PVC40	15	156.60 C	23.49	23.75 C	3.56
1 1/4" ELBOW 90 DEG - PVC40	2	366.38 C	7.33	32.50 C	0.65
3/4" COUPLING - PVC	22	42.40 C	9.33	0.00 C	0.00
1 1/4" COUPLING - PVC	2	96.87 C	1.94	0.00 C	0.00
3/4" ADAPTER MALE - PVC	14	73.90 C	10.35	12.50 C	1.75
1 1/4" ADAPTER MALE - PVC	2	131.68 C	2.63	17.50 C	0.35
3/4" ADAPTER FEM - PVC	6	81.80 C	4.91	12.50 C	0.75
4x 1 1/2" SQ BOX COMB KO	3	1,469.00 C	44.07	28.75 C	0.86
4" SQ 1G PLSTR RING 5/8" RISE	3	937.62 C	28.13	3.13 C	0.09
16x 16x 6" BOX CONT HNG - NEMA 4X	1	1,054.00 E	1,054.00	1.63 E	1.63
8x 8x 4" BOX SCREW CVR - NEMA 3R	1	41.30 E	41.30	0.88 E	0.88



**Moss**  
 2101 N ANDREWS AVE  
 FT LAUDERDALE, FL 33311  
 Telephone: (954) 524-5678

**Project Name:** FLPD  
**Project Number:** 23-414  
**Page Number:** 4  
**Change Order #:** 72  
**Change Order Date:** 12/19/2025

Description	Qty	Net Price U	Total Mat.	Labor U	Total Hrs.
1 5/8x 1 5/8x 14G STRUT GALV	10	450.87 C	45.09	12.50 C	1.25
6x 6x 3 1/2" POST BASE - ANGLE MNT 2-1 5/8x 1 5/8" STR	1	9,002.39 C	90.02	20.00 C	0.20
1/4-20x 1 3/4 WEDGE ANCHOR - 1 1/8" MIN DEPTH	2	60.00 C	1.20	10.00 C	0.20
3/8-16x 2 1/4 WEDGE ANCHOR - 1 1/2" MIN DEPTH	4	91.20 C	3.65	15.00 C	0.60
1/2-13x 2 3/4 WEDGE ANCHOR - 2 1/4" MIN DEPTH	4	163.13 C	6.53	20.00 C	0.80
1/4-20 MACHINE SCREW ANCHOR	10	29.24 C	2.92	10.00 C	1.00
1/4" THREADED ROD - PLTD	29	68.72 C	19.93	3.13 C	0.91
1/2-13x 1 1/2 HEX HEAD BOLT - PLTD STL	4	50.60 C	2.02	6.75 C	0.27
1/4-20 HEX NUT - PLTD STL	10	3.14 C	0.31	2.50 C	0.25
1/2" LOCK WASHER - PLTD STL	4	7.98 C	0.32	1.25 C	0.05
3/16x 1 1/4 CONCRETE SCREW HEX HEAD - BLUE	44	45.53 C	20.03	8.50 C	3.74
TIE WIRE (PER LB)	1	5.00 C	0.05	1.88 C	0.02
#12 THHN BLACK	84	257.16 M	21.60	6.44 M	0.54
#10 THHN BLACK	2,887	393.32 M	1,135.51	7.06 M	20.38
# 8 THHN BLACK	1,262	622.90 M	786.10	8.75 M	11.04
#12 THHN RED	0	257.16 M	0.00	0.00 M	0.00
#12 THHN BLUE	0	257.16 M	0.00	0.00 M	0.00
#12 THHN WHITE	84	257.16 M	21.60	6.44 M	0.54
#10 THHN WHITE	109	393.32 M	42.87	7.06 M	0.77
#12 THHN GREEN	112	257.16 M	28.80	6.44 M	0.72
#10 THHN GREEN	1,010	393.32 M	397.25	7.06 M	7.13
# 8 THHN GREEN	455	622.90 M	283.42	8.75 M	3.98
1/8" POLYTWINE	841	11.94 M	10.04	3.75 M	3.15
30A DSN SW - NEMA 3R	3	832.80 E	2,498.40	1.50 E	4.50
TYPE W1 TRIMOUT & INSTALLATION	3	0.00 E	0.00	1.00 E	3.00
<b>Totals</b>	<b>8,188</b>		<b>9,620.02</b>		<b>164.32</b>

**CLIENT ACCEPTANCE**

<b>Name:</b>	
<b>Date:</b>	
<b>Signature:</b>	
I hereby accept this quotation and authorize the contractor to complete the above described work.	

**Expiration Date: 10/22/25**

## Quotation

<b>TO:</b> THUNDER ELECTRICAL CONTRACTORS MIAM 7035-F SW 47TH ST MIAMI, FL 33155-4639	<b>Project Info:</b> Project: FLPD - SI006 Job #: 343173 Bid Date: 10/07/25 Bid Time: 02:00 PM EDT Quoter: JOHAN SANTOYO
--	---

Type	Quantity	Vendor	Description	Unit or Lot#	Unit Price	Ext Price
TAXES NOT INCLUDED						

W1	3		WPX1 LED P2 40K MVOLT DWHXD PE MERU-LED			
----	---	--	--	--	--	--

Terms and Conditions of Sale for Quotes

A. Seller assumes no responsibility whatsoever for any interpretation of bid documents, plans, or specifications provided to Seller (i.e., customer shall be solely responsible for ensuring interpretation of such documents, plans and/or specifications and for conformity and appropriateness of all goods and services ordered in comparison to same).

B. Prices are subject to change at any time prior to shipment unless otherwise agreed in writing signed by an authorized Seller representative.

C. Pricing and estimated delivery dates are based solely on the quantities and specific products and/or scope of services identified in this quote. Seller may refuse, terminate, or change pricing, estimated dates, and other terms of its offer if customer requests changes or deviations from the original quote. Unless an authorized Seller representative accepts customer's proposed deviations in an explicit signed agreement modifying this quotation, any such proposed deviations are automatically rejected, void, and of no force or effect.

D. Quotation does not include special mounting or installation hardware, equipment options, accessories, samples, spares, or mock-up equipment unless otherwise noted.

E. Seller is not responsible for the design of the project or any goods supplied.

F. Seller reserves the right to increase the pricing quoted herein to account for force majeure events, the

**From:**  
 WORLD ELECTRIC SUPPLY, LLC.  
 SALES 305-436-1500  
 2301 NW 107TH AVE  
 DORAL, FL 33172-2182  
 Printed By: JOHAN SANTOYO  
 Thanks ,  
 Johan Santoyo  
 Sales Representative

**Notes**

All transactions are subject to and exclusively governed by our Term and Conditions of Sale, which are incorporated herein and available at: <https://www.worldelectricssupply.com/terms#sale>. Additional or conflicting terms are rejected, void, and of no force or effect.

Project: FLPD - SI006

**Expiration**

**10/22/25**

## Quotation

Type	Quantity	Vendor	Description	LOT #	Unit Price	Ext Price
<p>imposition of new or increased tariffs, shipping costs, import/export fees, duties, customs, or taxes, currency fluctuations, or increases in commodity or market pricing.</p> <p>G. Pre-shipment of anchor bolts is plus freight.</p> <p>H. Where applicable, fabrication and shipment of goods can only be made after Seller receives the following: (i) purchase order conforming to this Quotation, (ii) customer's verification and approval of technical information, (iii) approved Submittal Drawings, and (iv) credit approval.</p> <p>I. Lead times are strictly estimates. Seller is not responsible for ship dates beyond estimated dates unless Seller's President or VP Finance otherwise explicitly agrees in a signed writing as part of this Quotation and then only to the extent so agreed.</p> <p>J. All orders are FCA Shipping Point, prepaid and billed, unless otherwise noted in quote.</p> <p>K. Logistic solutions, storage, handling, kitting, expedited or special delivery, testing, including, but not limited to, infrared scanning and NETA testing, spares, start-up, installation, commissioning, arc flash studies, and other services are excluded unless otherwise specified in this quote. Please contact your Seller representative for additional information on any such services if desired.</p> <p>L. This quotation and all related transactions are also subject to the applicable manufacturer's published warranties, including all applicable disclaimers, exclusions, and limitations.</p> <p>M. This quotation constitutes Seller's confidential information, and customer shall not share or distribute this quotation to third parties other than to the extent reasonably necessary to process the transactions contemplated herein with Seller.</p> <p>N. Unless otherwise expressly agreed in a separate writing signed by Seller's President or VP Finance, Seller does not agree and is not subject to any contractual flow-down or pass-through terms from customer, including, but not limited to, DFARs, FARs, Prime Contracts, Minority Business requirements, Buy America Act, etc.</p>						

**From:**

WORLD ELECTRIC SUPPLY, LLC.  
 SALES 305-436-1500  
 2301 NW 107TH AVE  
 DORAL, FL 33172-2182  
 Printed By: JOHAN SANTOYO  
 Thanks ,  
 Johan Santoyo  
 Sales Representative

**Total**

**1,950.00**

**Notes**

All transactions are subject to and exclusively governed by our Term and Conditions of Sale, which are incorporated herein and available at: <https://www.worldelectricssupply.com/terms#sale>. Additional or conflicting terms are rejected, void, and of no force or effect.



CHANGE ORDER#: 13

DATE: 12/19/2025

\*\*\* This change order is for ASI-006

Customer  
MossProject  
Fort Lauderdale Police Headquarters - PH 1 + 2  
1300 W Broward Blvd  
Fort Lauderdale, FL 33312  
Landscape

Telephone	Fax	Sales Rep	Terms	Original Plan Date	Revised Date
		Art Scroggie	UPON RECEIPT		
Quantity	Description				
	<b>Delete:</b>				
-1	MYRCIANTHES FRAGRANS (SIMPSON'S STOPPER)		10' HT. X 5' SPRD., 2" CAL. MULTI-TRUNK	\$ 500.00	\$ (500.00)
-8	NERIUM OLEANDER (OLEANDER)		18" HT. X 18" SPRD.	\$ 12.00	\$ (96.00)
-7	Pennisetum setaceum (WHITE FOUNTAIN GRASS)		24" HT. X 24" SPRD.	\$ 10.00	\$ (70.00)
	<b>Adds:</b>				
2	QUERCUS VIRGINIANA (SOUTHERN LIVE OAK)		15' HT X 6' SPRD, 4" CAL.	\$ 1,625.00	\$ 3,250.00
51	NEPHROLEPIS EXALTATA (BOSTON FERN)		12" HT X 14" SPRD., CERTIFIED NATIVE ON	\$ 16.25	\$ 828.75
5	TRIPSACUM DACTYLOIDES (FAKAHATCHEE GRASS)		24" HT. X 24" SPRD.	\$ 12.50	\$ 62.50

\*\*\* This change order is for ASI-006

TOTAL: \$ 3,475.25

ADD/ALT:

Payments to be made as follows: \$ \_\_\_\_\_ Deposit must be received prior to work commencement. \$ \_\_\_\_\_ Progress payment due when 2/3 of material and/or work as listed above has been installed. The balance is due upon completion. Bermuda Landscape will notify the customer upon completion. If any of the payments remain unpaid after a term of 30 days, the customer agrees to a service of 1.5% (18% per annum). If collections are commenced by Bermuda Landscape & Design, Inc., Customer agrees to pay reasonable fees, court cost, and all unpaid balances shall accrue interest at the highest rate permitted by law. Bermuda Landscape & Design, Inc. will not be held responsible for damages to any underground utilities. Owner is responsible for locating and marking all underground lines. Owner/Customer indemnifies and holds Bermuda Landscape & Design, Inc. harmless from any damages or claims of damages relating to underground lines or cables. Transplanted trees are not guaranteed. Bermuda Landscape & Design, Inc. is not responsible for damages to walkway, driveways, sprinklers or sod should we be required to cross any. Any guarantees or warranties shall commence the day the material is planted. Bermuda Landscape & Design, Inc. is not responsible for replacing any material that is damaged due to Acts of God or did not receive proper maintenance, i.e. water, fertilizer, insecticides, lethal yellowing, ect. All guarantees and warranties are null and void if contract is not paid in full and/or as per the above payments terms. It is the customer's responsibility to carry insurance against theft, Acts of God, ect. on all planted material. (Proposal may be withdrawn if not accepted within 30 days.)

Company Name: \_\_\_\_\_

Bermuda Landscape &amp; Design Inc.

Date: \_\_\_\_\_

By: \_\_\_\_\_

Date: \_\_\_\_\_

Customer Signature \_\_\_\_\_

Visit Us At [Bermudalandscape.com](http://Bermudalandscape.com)

Print Name and Title: \_\_\_\_\_

CAM #26-0510

Exhibit 3

Page 49 of 262

# FENCE MASTERS, INC.

3550 N. W. 54<sup>TH</sup> STREET  
MIAMI, FLORIDA 33142

DADE: (305)635-7777 \* BROWARD (954)463-3172 \* FAX: (305)635-7887

<b>Date:</b>	February 16, 2026	<b>Name:</b>	Mathew Kane
<b>Company:</b>	Moss & Associates	<b>Job Name:</b>	Ft Lauderdale police HQ & Parking garage
<b>Address:</b>	2101 N Andrews Ave., Suite #300		
<b>City:</b>	Ft. Lauderdale, FL 33311	<b>Job Address:</b>	FT lauderdale
<b>Phone:</b>	954-769-8055, Fax: 954-712-5999		

*We propose, subject to acceptance by Fence Masters, Inc., (seller) to perform work in accordance with quantities and sizes listed below. Before erection is begun, purchaser is to establish property line stakes and grade stakes and to remove all obstructions that may interfere with erection. Purchaser is responsible for location of any underground lines. Fence Masters, Inc. is not responsible for any damage to unmarked lines. After the contract is executed and received by Fence Masters, Inc., notice to proceed is to be provided by purchaser at least 14 days prior to date of commencement of the work. In order to avoid unforeseen conflicts in contract language, by signing this contract you are waiving any obligation on our part to sign any contract or other document that you subsequently may offer, provide, or demand. This contract will be the only contract for this job and is binding for both parties.*

Furnish & install  
Change order pricing on South Lot revision SI-006

Fence around curb at Dumpster Enclosure.

- 1) Add 32' of 8' high Ameristar Echelon II fence.
- 2) All posts on plates bolted to top of curb. Curb must be at least 8" wide.
- 3) All black in color.
- 4) Includes tax,

Material \$ 5,295.00  
Shop time to assemble the panels \$ 935.00  
Tax 7 % 371.00  
Overall material cost \$ 6,601.00  
Labor \$ 3,575.00  
10% Profit \$ 1,018.00  
Add \$ 11,194.00

350' of 8' high green vinyl clad chain link fence at new enclosure.

- 1) 9 Gauge core with green vinyl finish.
- 2) 3" OD Green SS 40 line posts set in concrete footings.
- 3) 3" OD terminal posts.
- 4) 1 5/8' top, middle and bottom rails.
- 5) 2 - 4' Man gates with standard fork latches.
- 6) 3" OD Gate posts.

Material Cost \$ 14,028.00  
Additional costs: concrete \$ 1024.00  
Tax 7% \$ 1,054.00  
Labor \$ 7,100.00 (Approximately 3 1/2 crew days @ \$ 2,000.00 per day )  
10% Profit \$ 2,321.00  
Add \$ 25,527.00

- 1) Add at confiscation car lot:
- 2) Add 1 - TyMetal 24' cantilever slide gate.
- 3) Modify Ameristar fence as required by the revision SI-006.
- 4) Add 1 - TyMetal slide gate operator on conc pad.
- 5) Add all safety and free exit loops required.
- 6) All access controls, wiring, conduit, and final hook up by others.

Material \$ 36,083.00  
Additional costs: Concrete pad \$ 160.00  
5 - 6 5/8" Schedule 40 gate posts @ 375.00 each Add \$ 1,875.00  
Concrete \$ 512.00  
Loops \$ 525.00  
Ground rod \$ 175.00  
Shop time for ameristar fence modification for new lay out \$ 2,886.00  
Tax 7 % 2,955.00

Labor \$ 17,650.00 (Approximately 9 Crew Days @ \$2,000 per day)  
10% profit \$ 6,282.00  
Add \$ 69,103.00

Delete 96' of 8' high galvanized chain link fence added to original contract as an alternate.

Delete \$ 11,569.00

Delete 1 – 11' by 8' high galvanized chain link swing gate at confiscation lot.

Delete \$ 750.00

Total Add \$ 93,505.00

Note: The above pricing is good for only 5 days do to the existing conditions in the steel industry. The mills won't guarantee the pricing to us for more than 5 days. After that, actual price is based on receipt date of executed contract and mill price increases.

**DEPOSIT N/A**

*Subject to credit approval by Fence Masters, Inc. Terms are net on billing. Prices for this proposal are valid for 5 days from the proposal date. Interest of 1 1/2 % per month will be charged on accounts past due. Title to the property as addressed by this proposal shall remain in the seller, Fence Masters, Inc. until payment in full is received, pursuant to the terms hereof. This is a retain title contract.*

*In the event the money due hereunder, or any portion thereof, has to be collected on demand of an attorney or by suit, the purchaser agrees to pay all costs of collection including interest at the highest legal rate and reasonable attorney's fees.*

Approved & Accepted: Fence Masters, Inc. (Seller)

Approved & Accepted by Purchaser:

Moss & Associates

By  Signature	By _____ Signature
---	-----------------------

Carlo S. Cortina, Project Manager

\_\_\_\_\_  
Print Name and Title



# TYMETAL

SECURITY GATES & PERIMETER SOLUTIONS

678 Wilbur Avenue, Greenwich, New York 12834  
 P:800.328.4283 F:518.692.9404 [www.tymetal.com](http://www.tymetal.com)

# QUOTATION

**Quote #** TYMQ173359  
**Date** 10/28/25  
**Sales Rep.** RRabine

**Quote To:**

**Carlo Cortina**  
 Fence Masters, Inc. - FL  
 3550 NW 54th St.  
 Miami, FL 33142  
 Phone: (305)300-8110

**Ship To:**

Ft Lauderdale PD 24x8 ORN STR HYD F

**Project Name:**

Ft Lauderdale PD 24x8 ORN STR HYD FL

Thank you for your inquiry regarding the above project, please find our quotation below.

Customer is responsible for compliance with plans and specifications for product type, material, size and quantity. If any of our quantities vary from yours, contact us and we will re-quote as needed.

Note: For sites with higher operational, non-typical, or specified wind loadings Tymetal should be advised of the site conditions and a specifically engineered design will be offered.

PRICING IS SUBJECT TO CHANGE DUE TO TARIFFS, TAXES, AND OTHER FEES.

Qty	Description	Opening Width	Gate Height	Unit Price	Ext. Price
1	Ornamental Structural Cantilever Slide Gate w/ HYD Operator			\$32,480.00	\$32,480.00
	Fortress Structural Cantilever Slide Gate (OAL = 36' 0")	24' 0"	8' 0"		

Gate to be fabricated in one piece.

1"x1" square aluminum pickets spaced approximately 3" o.c. Pickets will run through the opening portion of the gate only.

Note: Black, plastic mesh will be provided (to be installed by the customer) when the picket spacing allows for an opening greater than 2 1/4". The installation of a secondary filler is required per ASTM F2200 when a motorized gate operator is to be applied to the gate.

Curved, Smashed Point Pickets - Pickets extend above the top primary, but not below the bottom primary. A sample of the curved picket is required prior to fabrication if a match is to be made to a specific curve.

NOTE: Candy Cane or Shepherd's Hook style pickets are also available but not included in this quote. Contact Tymetal for pricing.

Gate to be powder coated stock, standard black. Non-stock, non-standard color coating will require an upcharge.

Cantilever Slide Gate Hardware for 4" ~~O.D.~~ Posts

6 5/8" OD

Qty	Description	Opening Width	Gate Height	Unit Price	Ext. Price
	Support posts by others. Five (5) posts are required for this gate.				
	<p>TYM-HYD VF2/3 Hydraulic Slide Gate Operator - 2hp with heater, UL 325 6th edition compliant. 2.2 ft/sec. or 3 ft/sec. Max. gate weight = 5000#. Choose: (208 or 230v, 1ph; 208, 230 or 460v, 3ph; 60 Hz). Smart Touch 725 Controller with Bluetooth Smartphone Interface and Soft stop/soft start using integrated variable frequency drive. Solid state dual limit sensors &amp; drive rail mounted limit flags. (5) configurable relays. Includes 8" Advanced Drive with 4.0 GPM pump pack. Outside cover is heavy 10 gauge galvanized steel with mogul lock (3 keys per key code included. Both cover and chassis are zinc plated steel with custom color powder coat gray (RAL 7038)).</p> <p>NOTE- External reset button not available on cover. Optional Loop modules sold separately.</p> <p>ELECTRICAL NOTE: Variable Frequency Motor Controllers requires proper grounding and clean power. Some installations have required additional transformers to regulate voltage within +/- 10% and have required transient voltage devices to condition supply power. These issues and devices are not part of Tymetal's scope.</p>				
	(3) Mogul Key for commercial motorbox lock TYC800A - 3 keys per code at no charge.				
	Portable ground rod kit for gate operators and lane access control pedestals. Includes 8' ground rod, ground rod clamp, and 6 ft of 6 gauge copper cable.				
	(2) HY 5B Loop Detector (uninstalled) -(replaces 25280) HyS plug in model requires only loop wire by others and attachment				
	<p>(2) Photoeye Kit with Shield Cone [70' &amp; less] - (1) Set of Independent Transmitter/Receiver &amp; Hoods with (2) mounting plates and mounting hardware. 10-24vac/ vdc with 115' range. Plates mount to separate 2" OD pipe to prevent vibration, appx 26" above grade. 2" OD support post pipe is supplied and installed by others. Includes 10K EOL Jumper feature for Post 2016 monitoring (not needed for VS models) and Manufactures operating instructions.</p> <p>INCLUDES: Tymetal Installation Manual (#24793)</p> <p>NOTE: A minimum of 2 kits are typically required as entrapment protection with a Tymetal Operator. Installer is responsible to ID all entrapment zones and install appropriate protective devices per UL 325 requirements. Both transmitter and receiver require conduits for wiring. AFA mounting instruction included.</p> <p>TECHNICAL: NEMA 4X 10-24vac/dc; 37ma total draw TX; 23ma total draw standby; 17ma detecting @ 24v. Emitter alone: 5mA draw. Contacts for 5a @30vdc/250vac. -40 to 170 degree F (Uses MON EMX IRB Only) replaces 45054</p>				
	Hardware Kit -Drive Rail Mount - ( Hyd Drive Rail Mtg Kit Includes 2" Square Stainless U bolts, 1/4 locknuts and spacer for 2" uprights, angles and drive rivets to terminate drive rail, and rollpins to connect rail. MUST				

Qty	Description	Opening Width	Gate Height	Unit Price	Ext. Price
	ref gate model and length for proper kit parts.)				
(3)	Drive Rail -traction blast-TYM 20'				
	Snow Brushes and Scrapers kit with mounting hardware- for 50VF2/3 cabinet that is predrilled, material must be field-attached. CAUTION:bristles may need trimming to avoid ramp-down switch interference				
	Strobe/Alarm combination, ADA compliant 24vdc 170mA [may require bridge rectifier #36352 - with 24vac input only) . Apex2 DC output is 750 mA				
* (3)	Hardware Kit -Drive Rail Mount - (Hyd Drive Rail Mtg Kit for Box Frame Roller includes fasteners for attaching hyd drive rail to gate mounting surface and plate for offsetting operator. Field drilling is required.)				
* (4)	Base Extension (12" riser, pedestal) fits under TYM-HYD slide gate operator ( 50VF2/3 ) painted matching Tymetal Custom Gray - customer installs on operator. 4 to 8 week lead time.				
	Dedicated trucking - the truck can be arranged per your project requirements, including the day and time of delivery.				

SubTotal	\$32,480.00
- Freight ESTIMATE	\$3,603.00
Sales Tax to be added unless Tymetal is provided with a tax exempt or resale certificate	
<b>Total</b>	<b>\$36,083.00</b>

Freight ESTIMATE is subject to prevailing market rates at the time of order placement.

Standard Lead-times: Swing Gates 4-6 weeks, Non-crash Gates 5-7 weeks, Ornamental gates 7-9 weeks, BFR Gates 12-14 weeks, 2150 Ped Gates 10-12 weeks, VPG 14-16 weeks, Crash Gates 12-14 weeks from receipt of all required documents. Add 2-3 weeks for powder coated gates. Expedited lead time may be available at an additional charge. Actual lead time to be determined upon placement of order.

Terms & Conditions: Please see TYMETAL CORP. - TERMS AND CONDITIONS.

Billing: If customer delays shipment of completed product, TYMETAL reserves the right to transfer ownership of the material to customer upon completion. If customer is not ready to receive completed product, then TYMETAL will store on premises for customer. Upon ownership transfer, TYMETAL will bill customer for product and payment will be required per terms and conditions of sale.

Payment: PREPAYMENT with PO unless existing TYMETAL Approved Credit Account, then Net 30 Days subject to Credit Limit Amount.

Currency: US Dollar.

This quotation is valid for 30 days from above date.

WARRANTY: The addition of any items or material (signs or decorations over 2 sq. ft., privacy slats, etc.) that adds weight or wind loading to the gate system may void your warranty. Tymetal is not responsible for damage to the gates as a result of excessive wind and weight loading. For In-fills installed by the end user over 1#/sq.ft. or with less than 75% open area consult Tymetal Engineering for suitability.

Accepted By: *[Signature]*  
Title: *Pres*  
Date: \_\_\_\_\_  
PO #: \_\_\_\_\_

Kind regards,

RRabine  
rrabine@tymetal.com

Quote # and total \$ value (PO Total): TYMQ173359 \$36,083.00

*+ TAX*

# AMERISTAR

## ASSA ABLOY

### SALES QUOTE

Order Number: 3815212-SQ  
 Order Date: 5/27/2025  
 Total (USD): \$14,506.84  
 Page: 1 of 2

Ameristar Tulsa  
 1555 N Mingo Rd  
 Tulsa, OK 74116-1506

Sold To: 4327821 FENCE MASTERS 3550 NW 54TH ST MIAMI FL 33142-3250 UNITED STATES	Ship To: 4327821 FENCE MASTERS 3550 NW 54TH ST MIAMI FL 33142-3250 UNITED STATES
--	--

Customer PO:	Quote	Order No:	3815212 SQ
Job Name:	20220110085422685Fort Lauderdale Police	Price Book:	
Carrier & Freight Method:		Freight Terms:	FOB ORIGIN, FREIGHT PREPAID
CCF #/Reference Order:		Load No:	0
Order By:	CARLO	Terr:	P13
Delivery Instructions:		Quote No:	
		Taken By:	TIMSMI

Line	Plant	Item Number / Description	Qty/UM	Weight	List	Discount	Net	Extended
1.000	Tulsa, OK	2AIB40948 ECH-II PNL INV 4R EXT 4"GAP 8'H 8'W BLK	16 / EA	1,603.18	467.8403		467.8403	7,485.44
		Requested Date: 5/27/2025			Scheduled Date: 5/27/2025			
2.000	Tulsa, OK	91-111-9437-1 PLT-POST 4"SQ .250" 84"L ALUM BLK 8"X4-1/2" 3/8"	18 / EA	597.05	274.4827		274.4827	4,940.69
		Requested Date: 5/27/2025			Scheduled Date: 5/27/2025			
3.000	Tulsa, OK	BB301SR IND FLAT MOUNT BRKT BLK 42/BOX	48 / BC	40.32	22.7532		22.7532	1,092.15
		Requested Date: 5/27/2025			Scheduled Date: 5/27/2025			
4.000	Tulsa, OK	6-0058PPFG SOCKET FOR TRI GROOVE NUTS PKG	3 / EA	.2700	6.4385		6.4385	19.32
		Requested Date: 5/27/2025			Scheduled Date: 5/27/2025			
5.000	Tulsa, OK	FB100	2 / EA	2.16	10.0984		10.0984	20.20
		Requested Date: 5/27/2025			Scheduled Date: 5/27/2025			

Ameristar Perimeter Security USA Inc.  
 R9942565 PSG0007  
 JOEAMRACK.qfs

ERP: 5/27/2025 135359  
 DP: 05/27/25 01:54 PM

**AMERISTAR**  
**ASSA ABLOY**

**SALES QUOTE**

Order Number: 3815212-SQ  
Order Date: 5/27/2025  
Total (USD): \$14,506.84  
Page: 2 of 2

Ameristar Tulsa  
1555 N Mingo Rd  
Tulsa, OK 74116-1506

<b>Sold To:</b> 4327821 FENCE MASTERS 3550 NW 54TH ST MIAMI FL 33142-3250 UNITED STATES	<b>Ship To:</b> 4327821 FENCE MASTERS 3550 NW 54TH ST MIAMI FL 33142-3250 UNITED STATES
---	---

<b>Customer PO:</b>	Quote	<b>Order No:</b>	3815212 SQ
<b>Job Name:</b>	20220110085422685Fort Lauderdale Police	<b>Price Book:</b>	
<b>Carrier &amp; Freight Method:</b>		<b>Freight Terms:</b>	FOB ORIGIN, FREIGHT PREPAID
<b>CCF #/Reference Order:</b>		<b>Load No:</b>	0
<b>Order By:</b>	CARLO	<b>Terr:</b>	P13
<b>Delivery Instructions:</b>		<b>Quote No:</b>	
		<b>Taken By:</b>	TIMSMI

Line	Plant	Item Number / Description	Qty/UM	Weight	List	Discount	Net	Extended
		BLACK CUSTOM FINISH SPRAY PAINT						

Signature: \_\_\_\_\_ Total Order Weight: 2,242.98

This acknowledgment supersedes the customer's purchase order in representing current pricing & shipping information. If the customer for any reason is not in agreement with the information listed above, please contact Customer Service at 1-888-333-3422 upon receipt of this document (delay in contact may affect the scheduled ship date). Any changes to this order may be subject to processing fees. Please refer to the Terms & Conditions section in the price book(s).

Terms: Net 30 Days

<b>Total Sale</b>	\$13,557.80
<b>Sales Tax</b>	\$949.04
<b>Freight</b>	\$ .00
<b>Total (USD)</b>	\$14,506.84

Ameristar Perimeter Security USA Inc.  
R5942585 PSG0007  
JDEAMRACK qfs

All quotes are subject to expire without notice at the time of internal price changes

ERP: 5/27/2025 135359  
DP: 05/27/25 01:54 PM

B-29-25  
P.O.# 17945C



525 Distribution Drive  
Melbourne, FL 32904  
(321) 728-2932  
Sales Fax: (321) 728-2933  
Sales Phone: (800) 290-7473

Remit Payment to:  
Stephens Pipe & Steel, LLC  
P.O. Box 618  
Russell Springs, KY 42642

Visit our website:  
<https://SPSfence.com>

QUOTATION #: 06-207145 Pg 1 of 1  
Billing Date : 9/8/2025  
Customer Acct: 30017  
Payment Terms: NET-60  
Customer PO #:  
Sales Person : P.NINESLING  
Made By User : pamelawilson  
SPS Order # : 0-0  
Shipped Via : OT  
Contact Name : STEVE ERNST  
Cust Mobile : 3057960163 STEVE  
Fax number : 3056357887

**\* Quote valid 10 days. Expires: 9/18/2025 \***

Sh Note: CALL JOHN 305.796.0164 FOR DELV

Sold To: FENCE MASTERS @MIAMI  
3550 NW 54TH ST  
MIAMI, FL 33142

Ship To: FENCE MASTERS @MIAMI  
(305) 635-7777  
3550 NW 54TH ST  
MIAMI, FL 33142

**\*\* Send Invoice by EMAIL ONLY.**

**CUSTOMER MUST FIELD VERIFY ALL MATERIALS. SPS IS NOT RESPONSIBLE FOR FINAL QUANTITIES OR TAKEOFFS!**

Ordered	Shipped	BackOrder	Unit	Product Item Description	Price	Amount
400	400	0	ft	GRN VNL 2B 2x8(9core)x96in KT 50ft/roll ** VERIFY SELVAGE	7.4866	2,994.64
1281	1281	0	ft	GRN PLY 1-5/8" x 21' x PP40 x 61pc	2.1699	2,779.64
48	48	0	pc	GRN PLY 2-1/2" x 10'6" x PP40	37.543	1,802.05
12	12	0	pc	GRN PLY 3" x 12' x PP40	67.26	807.12
2	2	0	pc	GRN VNL 6-5/8" x 12' x SPSch40 - nonstock	361.26	722.52
30	30	0	ea	GRN PLY TENSION BAR 96"x3/4"	9.506	285.18
84	84	0	ea	GRN PLY TENSION BAND 2in	1.3144	110.41
100	100	0	ea	GRN PLY TENSION BAND 3in	1.9927	199.27
14	14	0	ea	GRN PLY BEV TENSION BAND 6-5/8	5.1282	71.79
100	100	0	ea	GRN PLY BRACE BAND 3in	2.2039	220.39
6	6	0	ea	GRN PLY BEV BRACE BAND 6-5/8in	4.683	28.10
8	8	0	ea	GRN PLY IND BOX HINGE 90Deg 3in P.S.	37.609	300.88
4	4	0	ea	GRN PLY IND BOX HINGE 90Deg 6-5/8in P.S.	51.848	207.39
48	48	0	ea	GRN PLY PS LOOP CAP 2-1/2x1-5/8	4.9294	236.61
48	48	0	ea	GRN PLY PS RAIL END COMBO 1-5/8in	2.119	101.71
12	12	0	ea	GRN PLY PS DOME CAP 2in	2.3002	27.60
12	12	0	ea	GRN PLY PS DOME CAP 3in	4.1534	49.84
2	2	0	ea	GRN PLY PS DOME CAP 6-5/8in	16.079	32.16
2	2	0	ea	GRN IND DD 11'Wx8' 2"SP40 *Fab: F/O	708.62	1,417.24
2	2	0	ea	GRN IND SNG 14'Wx8' 2"SP40 *Fab: F/O	783.10	1,566.20
400	400	0	ea	BOLT/NUT 5/16x1-1/4in	0.087	34.80
200	200	0	ea	BOLT/NUT 3/8x2-1/2in	0.185	37.00
1200	1200	0	ea	GRN VNL STEEL TIE 9gax8-1/4in	0.113	135.60
20	20	0	ea	GRN PLY SLEEVE 1-5/8in	4.1534	83.07
100	100	0	set	GRN PLY BLVD CLAMP 2-1/2x1-5/8	6.6747	667.47
2	2	0	ea	GRN PLY 96"x2in DROP ROD ASMBLY	29.912	59.82
2	2	0	ea	GRN PLY IND LATCH 2x3 MAL	14.656	29.31
4	4	0	can	GRN PLY SPRAY PAINT	13.91	55.64

Accepted By: \_\_\_\_\_, Date \_\_\_/\_\_\_/\_\_\_ I HAVE REVIEWED  
AND DO ACCEPT THIS ORDER AS QUOTED. Use Reference P.O # \_\_\_\_\_  
Instructions:

15,063.45  
Fuel Charge 15.00  
7.0% Tax 954.71  
-----  
Total Order 16,033.16

Acceptance of quote confirms your approval of materials as quoted.  
Review all items. Any discrepancies MUST BE noted on original delivery document and VERIFIED BY DRIVER. Buyer agrees to pay all applicable taxes. Invoices not paid within terms will be charged a 1.5% monthly service charge. If payment made with credit card, a 2% convenience fee will be added. PRICES MAY CHANGE WITHOUT NOTICE! Returns subject to 15-50% Restock Fee. CAM#26-95499 P/D:09-08  
Exhibit 3



**Moss & Associates, LLC**  
 6363 NW 6th Way  
 Ft Lauderdale, FL 33309

May 04, 2026

Ronald Stein  
 City of Fort Lauderdale  
 101 NE 3rd Ave, Suite 2100  
 Ft. Lauderdale, FL 33301

RE: Potential Change Item (PCI) 0356 Notification  
 Fort Lauderdale Police Headquarters - B372302

Dear Ronald Stein,

This letter is to provide official notification of a potential change item (PCI) as follows:

PCI Number: 0356  
 Date: December 04, 2025  
 Description: Misc. Electrical and LV Changes  
 Days Requested:  
 Reason: Owner Directive - External  
 Scope Description: Electrical and LV relocations for rooms 1607, 1503, and Level 3 added copier locations. Also includes additional cables for furniture feeds and City IT requested (1') patch cables.

This PCI is comprised of the following items:

Added Cabling per COR #15	\$ 29,604.92
Electrical changes per COR #73R1	\$ 17,560.81
Drywall patchwork	\$ 3,000.00
Painting of patches	\$ 1,547.00
Electrical changes per COR #69R1	\$ 3,166.96
01 Subcontract Default Insurance 1.25%	\$ 686.00
02 Moss Insurance 1.75%	\$ 960.39
03 Bond 1%	\$ 548.80
04 Fee 4%	\$ 2,195.19

<b>Grand Total</b>	<b>\$59,270.07</b>
--------------------	--------------------

Per the terms and conditions of our contract, we have attached the appropriate back up documentation to substantiate the above referenced costs. This request only includes the items specifically identified in this change proposal. All other costs associated with this project shall be submitted under a separate change order cover.

The costs associated with this PCI will remain valid for fourteen (14) calendar days after submission.

Please indicate your formal approval for this additional work and cost by signing in the space provided below. Moss & Associates will then incorporate this change into the next Owner Change Order (OCO).

If you should have any questions, please contact the undersigned at 954-326-2727 as soon as possible.

<p>Sincerely,  <b>Moss &amp; Associates, LLC</b></p> <p>_____ Date: _____</p> <p>Matthew Kane          Sr. Project Manager</p>	<p>Reviewed / Approved by:  <b>City of Fort Lauderdale</b></p> <p><b>Approved:</b> _____ <b>Date:</b> _____          (Owner)</p>
--	--



Date: 11/11/2025

PROPOSAL NO: 210276 CO15	SUBMITTED TO: Matthew Kane
Moss & Associates LLC 2101 N. Andrews Ave. Ft. Lauderdale, Fl. 33311	<i>Job Location:</i> Ft. Lauderdale Police Dept. 1300 West Broward Blvd. Ft. Lauderdale, Fl. 33312
Phone Number: 321.427.3500	Email: mkane@mosscom.com

### Additional Cables for Furniture Feed, FL Box, Printers, 911 Center, AV Rack & Patch Cables

Quantity	Part #	Manufacture	Description	Material Cost	Unit	Totals	10% Overhead and Profit	Totals
238	Hourly Rate	Jade	Technician - Regular Time	\$87.000	HR	\$ 20,706.00		\$ 20,706.00
2720	10143424	Berk-Tek	Cat 6A Shielded Plenum Cable	\$0.750	LF	\$ 2,040.00	\$204.00	\$ 2,244.00
580	DOSP6AF	Belden	Cat 6A Wet Plenum Cable	\$1.100	LF	\$ 638.00	\$63.80	\$701.800
74	6ASJK-RE6	Leviton	Cat6A Shielded Jack	\$12.500	EA	\$ 925.00	\$92.50	\$ 1,017.50
2820	10136226	Berk-Tek	Cat6 Plenum Cable	\$0.260	EA	\$ 733.20	\$73.32	\$806.520
36	61110-RL6	Leviton	Cat6 Jacks Blue	\$5.250	EA	\$ 189.00	\$18.90	\$207.900
8	6AS10-3L	Leviton	3' Cat 6A Shielded Patch Cords	\$9.450	EA	\$ 75.60	\$7.56	\$ 83.16
8	6AS10-7L	Leviton	7' Cat 6A Shielded Patch Cords	\$13.500	EA	\$ 108.00	\$10.80	\$ 118.80
18	62460-07L	Leviton	7' Cat6 Patch Cable	\$9.000	EA	\$ 162.00	\$16.20	\$178.200
18	62460-03L	Leviton	3" Cat6 Patch Cable	\$6.000	EA	\$ 108.00	\$10.80	\$118.800
2	49256-VFR	Leviton	48 Port Cat6 Unloaded Angled Patch Panel	\$61.970	EA	\$ 123.94	\$12.39	\$136.334
12	42080-2WS	Leviton	2 Port Face plates	\$1.520	EA	\$ 18.24	\$1.82	\$20.064
6	41089-1WP	Leviton	1 Port Surface Mount Boxes	\$1.770	EA	\$ 10.62	\$1.06	\$11.682
50	CAT32HP	Caddy	2" J-Hooks	\$3.250	EA	\$ 162.50	\$16.25	\$ 178.75
74	Test	Jade	Test Cat 6/6A Cables	\$0.250	EA	\$ 18.50	\$1.85	\$ 20.35
1820	10139885	Berk-Tek	Wet Cat 6 CMP Cable	\$0.295	LF	\$ 536.90	\$53.69	\$590.590
500	6D460-01L	Leviton	1' Cat 6A Patch Cords	\$4.350	EA	\$ 2,175.00	\$217.50	\$2,392.500
5	41642-00B	Leviton	1 Gang Decora Quick 2 Port insert	\$3.520	EA	\$ 17.60	\$1.76	\$19.360
1	VDV826-703		50 pack-RJ45 pass thru	\$45.630	EA	\$ 45.63	\$4.56	\$50.193
1	41084-BW	Leviton	Snap-In Blank, Quickport Module, White, (10PC)	\$2.200	EA	\$ 2.20	\$0.22	\$2.420
								\$ 29,604.92

We hereby propose to furnish labor and materials-complete in accordance with the above specifications, for the sum of \$ **29,604.92**

#### **Balance due upon receipt of invoice.**

All material is guaranteed to be as specified. All work above to be completed in a skillful manner according to standard practices. Any alteration or deviation from above specifications involving extra cost, will be executed only upon written orders, and will become a "T & M" extra charge over and above the estimate. All agreements are contingent upon strikes, accidents or delays beyond our control. No permit fees or bonding is included in this quotation. This proposal is subject to acceptance within thirty days and is void hereafter at the option of the undersigned. Florida License ES0000112. Pricing includes all sales tax.

**AUTHORIZED NAME**      **Serge Leblanc**      **11/11/2025**

### **ACCEPTANCE OF PROPOSAL**

The above prices, specifications and conditions are hereby accepted. You are authorized to do the work as specified. Payment will be made as outlined above.

6610 E. ROGERS CIRCLE ° BOCA RATON, FLORIDA 33487 ° (561) 997-8552 ° FAX (561) 997-5935



ACCEPTED:

Signature \_\_\_\_\_ Date \_\_\_\_\_



**Moss**  
2101 N ANDREWS AVE  
FT LAUDERDALE, FL 33311  
Telephone: (954) 524-5678

**RFI#**  
**Project Name:** FLPD  
**Project Number:** 23-414  
**Page Number:** 1  
**Change Order #:** 73R1  
**Change Order Date:** 5/4/2026

---

### Scope of work

---

At the request of ownership, this change order proposal includes the labor and materials associated with providing electrical power receptacles and telecommunication service outlets for additional copy/printer equipment on Levels 1 and 3 of the headquarters building. All affected areas are in the final stages of the construction phase. Existing drywall will need to be demolished as required to allow for the installation of additional sleeves, conduit, and box provisions.

#### Level 1 - Room 1607:

The requested power receptacle will be installed using an MC cable jumper connected from the existing receptacle circuit within the room.

#### Level 3:

The additional power requirements will be served by new conduit and wire homeruns routed from the North Electrical Room (Room 3802) to a pull box located in the corridor. Due to the number of bends in the conduit routing, the pull box will serve as a transition point before the conduits are split and distributed to the respective rooms. Fire caulking will be applied to all electrical homerun penetrations from the electrical room. Panel schedules for panels LB3-3 and LB3-4 will be updated accordingly.

#### Low Voltage Scope:

Additional low voltage drops are also being requested under this design revision for the printers. Each printer will require one (1) low voltage cable. The telecom symbol legend has been updated to reflect a (1) cable telecom service outlet consisting of the following:

- (1) 4-11/16" (2-1/8" deep) flush-mount box with single gang reducer ring
- (1) 1" conduit stubbed to the accessible ceiling

All added sleeves and conduit runs for these new telecom service outlets have been included in this proposal's pricing.

#### HQ-E2-2-1A:

- (2) RM 1607 DRYWALL DEMO LABOR FOR MC CABLE AND BOX PROVISIONS
- MC CABLE IN ACCESSABLE CEILING FOR JUMPER ADDED RECEPTACLE - (#10/2C CABLE MC CAB) LENGTH: 48.51'
- (1) RM 1607 20A 125V DUP REC - (MC CABLE - METAL STUD)

#### HQ-T2-1-1A:

- (1) DATA OUTLET ROUGH-IN BOX W/ STUP-UP (1" EMT METAL STUD UP)
- (2) RM 1607 DRYWALL DEMO LABOR FOR DATA BOX AND STUB-UP PROVISIONS
- RM 1607 DATA OUTLET CONDUIT SLEEVE TO CABLE TRAY - (1" EMT T-ROD FRM CONC) LENGTH: 2.13'

#### HQ-E2-2-3A:

- L3B-3/ 37 & 39 HR FRM PNL TO BOX - (3/4" EMT STRUT MOUNT) LENGTHS: 154.00      1.00
- L3B-3/39 HR ROUTE FRM BOX TO RECEP - (3/4" EMT T-ROD FROM CONC) LENGTHS: 67.09
- L3B-3/37 HR ROUTE FRM BOX TO RECEP - (3/4" EMT T-ROD FROM CONC) LENGTHS: 78.13
- (2) PROVISION FOR DUP RECEP L3B-3/ 37 & 39 - (3/4" EMT-METAL STUD)
- (8) LVL 3A DRYWALL DEMO LABOR FOR SLEEVES, CONDUIT AND BOX PROVISIONS

HQ-E2-2-3B:-L3B-4/37 HR FRM PNL TO BOX - (3/4" EMT STRUT MOUNT) LENGTH: 103.63'

Phone: 305-669-1776      Fax: 305-669-1710



RFI#  
**Project Name:** FLPD  
**Project Number:** 23-414  
**Page Number:** 2  
**Change Order #:** 73R1  
**Change Order Date:** 5/4/2026

**Moss**  
 2101 N ANDREWS AVE  
 FT LAUDERDALE, FL 33311  
 Telephone: (954) 524-5678

- L3B-4/37 HR ROUTE FRM BOX TO RECEP - (3/4" EMT T-ROD FROM CONC) LENGTH: 24.53'
- (1) PROVISION FOR DUP RECEP L3B-4/37 - (3/4" EMT-METAL STUD)
- (2) LVL 3B DRYWALL DEMO LABOR FOR SLEEVES, CONDUIT AND BOX PROVISIONS

HQ-E5-3-11:  
 -(2) CREATE/INSTLLATION OF NEW PANEL SCHEDULE: LB3-3 & LB3-4

- HQ-T2-1-3A:
- (1) DATA OUTLET ROUGH-IN BOX W/ STUP-UP (1" EMT METAL STUD UP)
  - 3112 DATA OUTLET CONDUIT SLEEVE TO CABLE TRAY - (1" EMT T-ROD FRM CONC) LENGTH: 12.03'
  - 3117 DATA OUTLET CONDUIT SLEEVE TO CABLE TRAY - (1" EMT T-ROD FRM CONC) LENGTH: 5.47'
  - 3200 DATA OUTLET CONDUIT SLEEVE TO CABLE TRAY - (1" EMT T-ROD FRM CONC) LENGTH: 5.97'
  - (6) LVL 3A DRYWALL DEMO LABOR FOR SLEEVES, CONDUIT & BOX PROVISIONS

- HQ-T2-1-3B:
- (1) DATA OUTLET ROUGH-IN BOX W/ STUP-UP (1" EMT METAL STUD UP)
  - DATA OUTLET CONDUIT FROM BOX STUB-UP TO CABLE TRAY - (1" EMT T-ROD FROM CONC) LENGTH: 22.72'
  - (1) LVL 3B DRYWALL DEMO LABOR FOR SLEEVES, CONDUIT & BOX PROVISIONS

Clouded changes shown on drawings HQ-A2-6-1C, HQ-E2-2-1C, and HQ-T2-1-1C were considered in a prior chnage order proposal. Please see Thunder Change order proposal #69.

**This change order excludes the following:**

- Demolition or removal of completed millwork.
- Repair, patching, or painting/finishing of any surface impacted by the conduit and or box rough in needed to complete this work.
- Concrete back filling.
- Any A/V equipment, terminations, or final device installation
- Any low voltage cabling, terminations, or free wire cabling support by LV trade partner.
- Ceiling or access tile removal/replacement outside normal conduit and box scope.
- Specialty or custom box/enclosure and or finish plates by others.
- Any terminations into action targets system to be done by others.
- Any waterproofing (to be performed by others)

**All remedial or repair work necessary due to these changes is to be performed by others.**

---

**Summary**

---

<b>MATERIAL</b>		
General Materials		4,058.43
Material Tax	(@ 7.000 %)	284.09
		<b>4,342.52</b>

Phone: 305-669-1776 Fax:305-669-1710



RFI#  
**Project Name:** FLPD  
**Project Number:** 23-414  
**Page Number:** 3  
**Change Order #:** 73R1  
**Change Order Date:** 5/4/2026

**Moss**  
 2101 N ANDREWS AVE  
 FT LAUDERDALE, FL 33311  
 Telephone: (954) 524-5678

---

**Summary (Cont'd)**

---

**LABOR**

ELECTRICIAN	(142.28 Hrs @ \$55.00)	7,825.40
FOREMAN	(33.07 Hrs @ \$65.00)	2,149.55
SUPERINTENDENT	(13.23 Hrs @ \$70.00)	926.10
PROJECT MANAGER	(3.97 Hrs @ \$85.00)	337.45
BIM COORDINATION	(3.97 Hrs @ \$55.00)	218.35
ESTIMATING	(3.00 Hrs @ \$55.00)	165.00

<b>Total Labor</b>		<b>11,621.85</b>
--------------------	--	------------------

<b>TOTAL MATERIAL, LABOR &amp; EQUIPMENT</b>		<b>15,964.37</b>
--	--	------------------

OH&P	(@ 10.000 %)	1,596.44
------	--------------	----------

<b>Final Amount</b>		<b>\$17,560.81</b>
---------------------	--	--------------------



**Moss**  
 2101 N ANDREWS AVE  
 FT LAUDERDALE, FL 33311  
 Telephone: (954) 524-5678

**Project Name:** FLPD  
**Project Number:** 23-414  
**Page Number:** 4  
**Change Order #:** 73R1  
**Change Order Date:** 5/4/2026

**Itemized Breakdown**

**HQ-E2-2-1A**

Description	Qty	Net Price U	Total Mat.	Labor U	Total Hrs.
FIRESTOP COMPOUND CAULK (1) PIPE	1	1.00 E	1.00	0.06 E	0.06
4x 1 1/2" SQ BOX COMB KO W/ FLUSH MTL STUD BRKT	1	1,960.60 C	19.61	28.75 C	0.29
4" SQ 1G PLSTR RING 5/8" RISE	1	937.62 C	9.38	3.13 C	0.03
GROUND SCREW W/ INSUL #12 LEAD	1	503.57 C	5.04	3.75 C	0.04
#8x 1/2 WAFER HEAD SHEET MTL SCREW	6	6.04 C	0.36	1.88 C	0.11
TIE WIRE (PER LB)	2	5.00 C	0.10	1.88 C	0.04
#12/2C CABLE MC - ALUM ARMOR	22	862.08 M	18.97	19.00 M	0.42
#10/2C CABLE AC-90 - STL ARMOR	53	1,838.56 M	97.44	26.25 M	1.39
3/8" CONN SADDLEGRIP DC FOR FLEX / AC-90 / MC	2	98.42 C	1.97	7.50 C	0.15
1/2" CONN SADDLEGRIP DC FOR FLEX / AC-90 / MC	4	127.70 C	5.11	11.25 C	0.45
NMC OR MC/AC SUPPORT TO WOOD OR MTL STUD	1	71.86 C	0.72	6.25 C	0.06
CABLE/CONDUIT ANTI-RATTLE SUPPORT FOR MTL STU	4	48.44 C	1.94	5.00 C	0.20
WIRE CONN RED	2	19.64 C	0.39	4.00 C	0.08
1G DECORATOR PLATE - PLASTIC IVY	1	138.50 C	1.39	3.75 C	0.04
20A 125V DUP REC - DECOR IVY (SG)	1	1,560.00 C	15.60	25.00 C	0.25
DRYWALL DEMO LABOR	2	0.00 E	0.00	1.00 E	2.00
<b>Totals</b>	<b>104</b>		<b>179.00</b>		<b>5.61</b>

**HQ-T2-1-1A**

Description	Qty	Net Price U	Total Mat.	Labor U	Total Hrs.
FIRESTOP COMPOUND CAULK (1) PIPE	4	1.00 E	4.00	0.06 E	0.24
1" CONDUIT - EMT	32	257.91 C	82.53	5.60 C	1.79
1" CONN SS STL - EMT	6	377.00 C	22.62	15.00 C	0.90
1" COUPLING SS STL - EMT	4	401.07 C	16.04	0.00 C	0.00
1" INSULATING BUSHING - EMT	2	98.37 C	1.97	6.50 C	0.13
1" CONDUIT SNAP CLOSE CLIP W/ 1/4-20 THRD HOLE	2	69.13 C	1.38	7.75 C	0.16
1" SNAP CLOSE CLIP - SIDE MNT TO MTL STUD SUPP	6	213.60 C	12.82	9.88 C	0.59
4 11/16x 2 1/8" SQ BOX COMB KO	1	2,821.85 C	28.22	31.25 C	0.31
4 11/16" SQ 1G PLSTR RING 5/8" RISE	1	2,587.73 C	25.88	3.13 C	0.03
1/4-20 MACHINE SCREW ANCHOR	2	29.24 C	0.58	10.00 C	0.20
1/4" THREADED ROD - PLTD	7	68.72 C	4.81	3.13 C	0.22
1/4-20 HEX NUT - PLTD STL	2	3.14 C	0.06	2.50 C	0.05
3/16x 1 1/4 CONCRETE SCREW HEX HEAD - BLUE	8	45.53 C	3.64	8.50 C	0.68

Phone: 305-669-1776 Fax: 305-669-1710



**Moss**  
 2101 N ANDREWS AVE  
 FT LAUDERDALE, FL 33311  
 Telephone: (954) 524-5678

**Project Name:** FLPD  
**Project Number:** 23-414  
**Page Number:** 5  
**Change Order #:** 73R1  
**Change Order Date:** 5/4/2026

Description	Qty	Net Price U	Total Mat.	Labor U	Total Hrs.
#8x 1/2 WAFER HEAD SHEET MTL SCREW	8	6.04 C	0.48	1.88 C	0.15
#12 THHN BLACK	28	257.16 M	7.20	6.44 M	0.18
# 6 THHN GREEN	1	1,064.83 M	1.06	11.13 M	0.01
WIRE CONN RED	12	19.64 C	2.36	4.00 C	0.48
1/8" POLYTWINE	28	11.94 M	0.33	3.75 M	0.11
# 4 TO #2/0 CABLE TRAY CLAMP	1	2,001.06 C	20.01	27.50 C	0.28
1/2" TO 1" BRONZE CONDUIT GROUND CLAMP	1	7.98 E	7.98	0.25 E	0.25
DRYWALL DEMO LABOR	2	0.00 E	0.00	1.00 E	2.00
<b>Totals</b>	<b>158</b>		<b>243.99</b>		<b>8.75</b>

**HQ-E2-2-3A**

Description	Qty	Net Price U	Total Mat.	Labor U	Total Hrs.
FIRESTOP COMPOUND CAULK (1) PIPE	2	1.00 E	2.00	0.06 E	0.12
3/4" CONDUIT - EMT	347	154.78 C	537.09	4.40 C	15.27
3/4" CONN SS STL - EMT	14	228.82 C	32.03	12.50 C	1.75
3/4" COUPLING SS STL - EMT	36	268.91 C	96.81	0.00 C	0.00
3/4" EMT & 1/2" RMC 1-PC STRUT CLAMP W/ SADDLE -	16	170.91 C	27.35	6.38 C	1.02
1/2 OR 3/4" CONDUIT SNAP CLOSE CLIP W/ 1/4-20 THRD	15	52.18 C	7.83	7.13 C	1.07
1/2 OR 3/4" SNAP CLOSE CLIP - SIDE MNT TO MTL STUD	4	178.59 C	7.14	9.00 C	0.36
1/2 OR 3/4" SNAP CLOSE CLIP ON ANGLE BRKT	4	133.36 C	5.33	10.25 C	0.41
1/2 OR 3/4" CONDUIT+BOX SUPPORT W/ 9/32" MNTG HOL	4	489.61 C	19.58	9.75 C	0.39
4x 1 1/2" SQ BOX COMB KO W/ FLUSH MTL STUD BRKT	2	1,960.60 C	39.21	28.75 C	0.57
4" SQ 1G PLSTR RING 5/8" RISE	2	937.62 C	18.75	3.13 C	0.06
6x 6x 4" BOX SCREW CVR PNTD - NEMA 1	1	16.80 E	16.80	0.75 E	0.75
GROUND SCREW W/ INSUL #12 LEAD	2	503.57 C	10.07	3.75 C	0.07
1/4-20 MACHINE SCREW ANCHOR	20	29.24 C	5.85	10.00 C	2.00
1/4" THREADED ROD - PLTD	62	68.72 C	42.61	3.13 C	1.94
1/4-20 HEX NUT - PLTD STL	25	3.14 C	0.79	2.50 C	0.63
1/4" FLAT WASHER - PLTD STL	2	2.92 C	0.06	1.25 C	0.03
3/16x 1 1/4 CONCRETE SCREW HEX HEAD - BLUE	32	45.53 C	14.57	8.50 C	2.72
#8x 1/2 WAFER HEAD SELF-TAP STUD SCREW - 12G	8	3.26 C	0.26	1.50 C	0.12
#8x 1/2 WAFER HEAD SHEET MTL SCREW	14	6.04 C	0.85	1.88 C	0.26
#12 THHN BLACK	112	257.16 M	28.80	6.44 M	0.72
#10 THHN BLACK	1,109	393.32 M	436.19	7.06 M	7.83
#12 THHN GREEN	56	257.16 M	14.40	6.44 M	0.36
#10 THHN GREEN	708	393.32 M	278.47	7.06 M	5.00
WIRE CONN RED	16	19.64 C	3.14	4.00 C	0.64
1/8" POLYTWINE	327	11.94 M	3.90	3.75 M	1.23

Phone: 305-669-1776 Fax: 305-669-1710



**Moss**  
 2101 N ANDREWS AVE  
 FT LAUDERDALE, FL 33311  
 Telephone: (954) 524-5678

**Project Name:** FLPD  
**Project Number:** 23-414  
**Page Number:** 6  
**Change Order #:** 73R1  
**Change Order Date:** 5/4/2026

Description	Qty	Net Price U	Total Mat.	Labor U	Total Hrs.
1G DECORATOR PLATE - PLASTIC IVY	2	138.50 C	2.77	3.75 C	0.07
20A 125V - DECOR TR WHITE	2	15.60 E	31.20	25.00 C	0.50
DRYWALL DEMO LABOR	8	0.00 E	0.00	1.00 E	8.00
<b>Totals</b>	<b>2,952</b>		<b>1,683.86</b>		<b>53.90</b>

**HQ-E2-2-3B**

Description	Qty	Net Price U	Total Mat.	Labor U	Total Hrs.
FIRESTOP COMPOUND CAULK (1) PIPE	9	1.00 E	9.00	0.06 E	0.54
3/4" CONDUIT - EMT	153	154.78 C	236.81	4.40 C	6.73
3/4" CONN SS STL - EMT	10	228.82 C	22.88	12.50 C	1.25
3/4" COUPLING SS STL - EMT	15	268.91 C	40.34	0.00 C	0.00
3/4" EMT & 1/2" RMC 1-PC STRUT CLAMP W/ SADDLE -	11	170.91 C	18.80	6.38 C	0.70
1/2 OR 3/4" CONDUIT SNAP CLOSE CLIP W/ 1/4-20 THRD	3	52.18 C	1.57	7.13 C	0.21
1/2 OR 3/4" SNAP CLOSE CLIP - SIDE MNT TO MTL STUD	2	178.59 C	3.57	9.00 C	0.18
1/2 OR 3/4" SNAP CLOSE CLIP ON ANGLE BRKT	2	133.36 C	2.67	10.25 C	0.20
1/2 OR 3/4" CONDUIT+BOX SUPPORT W/ 9/32" MNTG HOL	2	489.61 C	9.79	9.75 C	0.20
4x 1 1/2" SQ BOX COMB KO W/ FLUSH MTL STUD BRKT	1	1,960.60 C	19.61	28.75 C	0.29
4" SQ 1G PLSTR RING 5/8" RISE	1	937.62 C	9.38	3.13 C	0.03
6x 6x 4" BOX SCREW CVR PNTD - NEMA 1	2	16.80 E	33.60	0.75 E	1.50
GROUND SCREW W/ INSUL #12 LEAD	1	503.57 C	5.04	3.75 C	0.04
1/4-20 MACHINE SCREW ANCHOR	7	29.24 C	2.05	10.00 C	0.70
1/4" THREADED ROD - PLTD	20	68.72 C	13.74	3.13 C	0.63
1/4-20 HEX NUT - PLTD STL	11	3.14 C	0.35	2.50 C	0.28
1/4" FLAT WASHER - PLTD STL	4	2.92 C	0.12	1.25 C	0.05
3/16x 1 1/4 CONCRETE SCREW HEX HEAD - BLUE	13	45.53 C	5.92	8.50 C	1.11
#8x 1/2 WAFER HEAD SELF-TAP STUD SCREW - 12G	4	3.26 C	0.13	1.50 C	0.06
#8x 1/2 WAFER HEAD SHEET MTL SCREW	7	6.04 C	0.42	1.88 C	0.13
#12 THHN BLACK	56	257.16 M	14.40	6.44 M	0.36
#10 THHN BLACK	496	393.32 M	195.09	7.06 M	3.50
#12 THHN GREEN	28	257.16 M	7.20	6.44 M	0.18
#10 THHN GREEN	207	393.32 M	81.42	7.06 M	1.46
WIRE CONN RED	8	19.64 C	1.57	4.00 C	0.32
1/8" POLYTWINE	129	11.94 M	1.54	3.75 M	0.48
1G DECORATOR PLATE - PLASTIC IVY	1	138.50 C	1.39	3.75 C	0.04
20A 125V - DECOR TR WHITE	1	15.60 E	15.60	25.00 C	0.25
DRYWALL DEMO LABOR	2	0.00 E	0.00	1.00 E	2.00
<b>Totals</b>	<b>1,206</b>		<b>753.97</b>		<b>23.42</b>

Phone: 305-669-1776 Fax: 305-669-1710



**Moss**  
 2101 N ANDREWS AVE  
 FT LAUDERDALE, FL 33311  
 Telephone: (954) 524-5678

**Project Name:** FLPD  
**Project Number:** 23-414  
**Page Number:** 7  
**Change Order #:** 73R1  
**Change Order Date:** 5/4/2026

**HQ-E5-3-11**

Description	Qty	Net Price U	Total Mat.	Labor U	Total Hrs.
CREATE/INSTLLATION OF NEW PANEL SCHEDULE	2	0.00 E	0.00	0.55 E	1.10
<b>Totals</b>	<b>2</b>		<b>0.00</b>		<b>1.10</b>

**HQ-T2-1-3A**

Description	Qty	Net Price U	Total Mat.	Labor U	Total Hrs.
FIRESTOP COMPOUND CAULK (1) PIPE	12	1.00 E	12.00	0.06 E	0.72
1" CONDUIT - EMT	113	257.91 C	291.44	5.60 C	6.33
1" CONN SS STL - EMT	18	377.00 C	67.86	15.00 C	2.70
1" COUPLING SS STL - EMT	15	401.07 C	60.16	0.00 C	0.00
1" INSULATING BUSHING - EMT	6	98.37 C	5.90	6.50 C	0.39
1" CONDUIT SNAP CLOSE CLIP W/ 1/4-20 THRD HOLE	9	69.13 C	6.22	7.75 C	0.70
1" SNAP CLOSE CLIP - SIDE MNT TO MTL STUD SUPP	18	213.60 C	38.45	9.88 C	1.78
4 11/16x 2 1/8" SQ BOX COMB KO	3	2,821.85 C	84.66	31.25 C	0.94
4 11/16" SQ 1G PLSTR RING 5/8" RISE	3	2,587.73 C	77.63	3.13 C	0.09
1/4-20 MACHINE SCREW ANCHOR	9	29.24 C	2.63	10.00 C	0.90
1/4" THREADED ROD - PLTD	26	68.72 C	17.87	3.13 C	0.81
1/4-20 HEX NUT - PLTD STL	9	3.14 C	0.28	2.50 C	0.23
3/16x 1 1/4 CONCRETE SCREW HEX HEAD - BLUE	27	45.53 C	12.29	8.50 C	2.29
#8x 1/2 WAFER HEAD SHEET MTL SCREW	24	6.04 C	1.45	1.88 C	0.45
#12 THHN BLACK	310	257.16 M	79.72	6.44 M	2.00
# 6 THHN GREEN	9	1,064.83 M	9.58	11.13 M	0.10
WIRE CONN RED	36	19.64 C	7.07	4.00 C	1.44
1/8" POLYTWINE	135	11.94 M	1.61	3.75 M	0.51
# 4 TO #2/0 CABLE TRAY CLAMP	3	2,001.06 C	60.03	27.50 C	0.82
1/2" TO 1" BRONZE CONDUIT GROUND CLAMP	3	7.98 E	23.94	0.25 E	0.75
DRYWALL DEMO LABOR	6	0.00 E	0.00	1.00 E	6.00
<b>Totals</b>	<b>794</b>		<b>860.80</b>		<b>29.95</b>

**HQ-T2-1-3B**

Description	Qty	Net Price U	Total Mat.	Labor U	Total Hrs.
FIRESTOP COMPOUND CAULK (1) PIPE	2	1.00 E	2.00	0.06 E	0.12
1" CONDUIT - EMT	53	257.91 C	136.69	5.60 C	2.97
1" CONN SS STL - EMT	4	377.00 C	15.08	15.00 C	0.60
1" COUPLING SS STL - EMT	6	401.07 C	24.06	0.00 C	0.00

Phone: 305-669-1776 Fax: 305-669-1710



**Moss**  
 2101 N ANDREWS AVE  
 FT LAUDERDALE, FL 33311  
 Telephone: (954) 524-5678

**Project Name:** FLPD  
**Project Number:** 23-414  
**Page Number:** 8  
**Change Order #:** 73R1  
**Change Order Date:** 5/4/2026

Description	Qty	Net Price U	Total Mat.	Labor U	Total Hrs.
1" CONDUIT SNAP CLOSE CLIP W/ 1/4-20 THRD HOLE	3	69.13 C	2.07	7.75 C	0.23
1" SNAP CLOSE CLIP - SIDE MNT TO MTL STUD SUPP	6	213.60 C	12.82	9.88 C	0.59
4 11/16x 2 1/8" SQ BOX COMB KO	1	2,821.85 C	28.22	31.25 C	0.31
4 11/16" SQ 1G PLSTR RING 5/8" RISE	1	2,587.73 C	25.88	3.13 C	0.03
1/4-20 MACHINE SCREW ANCHOR	3	29.24 C	0.88	10.00 C	0.30
1/4" THREADED ROD - PLTD	10	68.72 C	6.87	3.13 C	0.31
1/4-20 HEX NUT - PLTD STL	3	3.14 C	0.09	2.50 C	0.07
3/16x 1 1/4 CONCRETE SCREW HEX HEAD - BLUE	6	45.53 C	2.73	8.50 C	0.51
#8x 1/2 WAFER HEAD SHEET MTL SCREW	8	6.04 C	0.48	1.88 C	0.15
#12 THHN BLACK	300	257.16 M	77.15	6.44 M	1.93
WIRE CONN RED	6	19.64 C	1.18	4.00 C	0.24
1/8" POLYTWINE	51	11.94 M	0.61	3.75 M	0.19
DRYWALL DEMO LABOR	1	0.00 E	0.00	1.00 E	1.00
<b>Totals</b>	<b>464</b>		<b>336.82</b>		<b>9.57</b>

**CLIENT ACCEPTANCE**

<b>Name:</b>	
<b>Date:</b>	
<b>Signature:</b>	
I hereby accept this quotation and authorize the contractor to complete the above described work.	

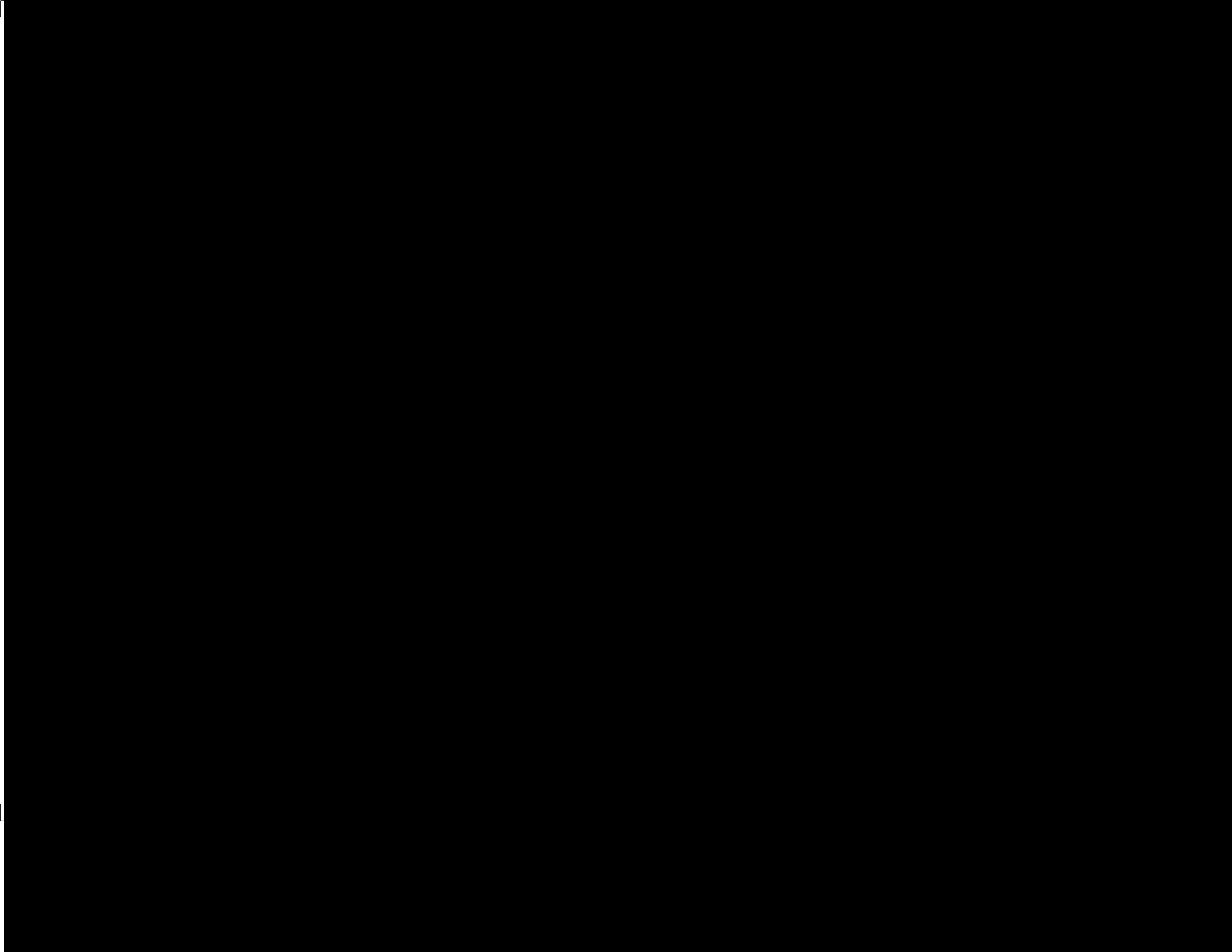
## Brandon Rodriguez

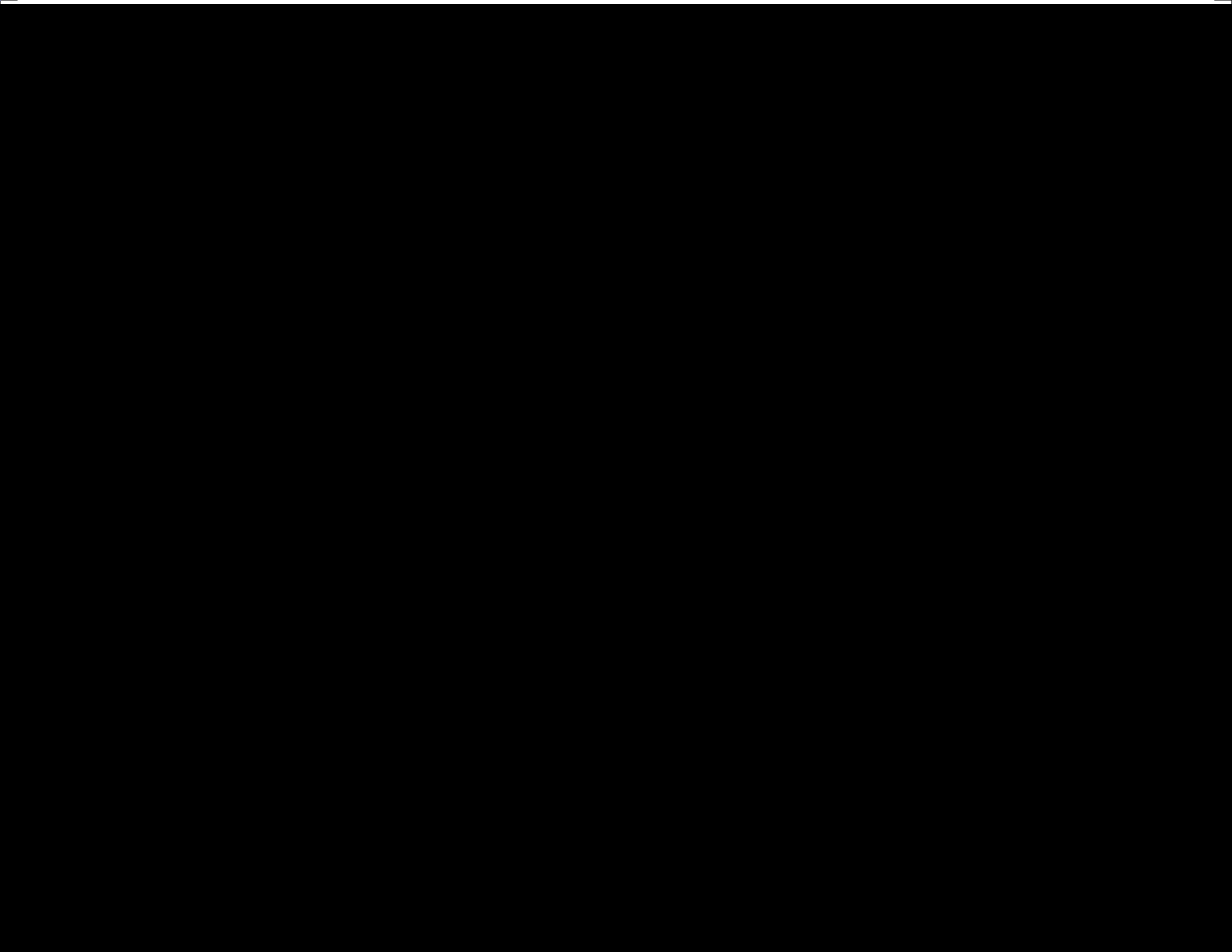
---

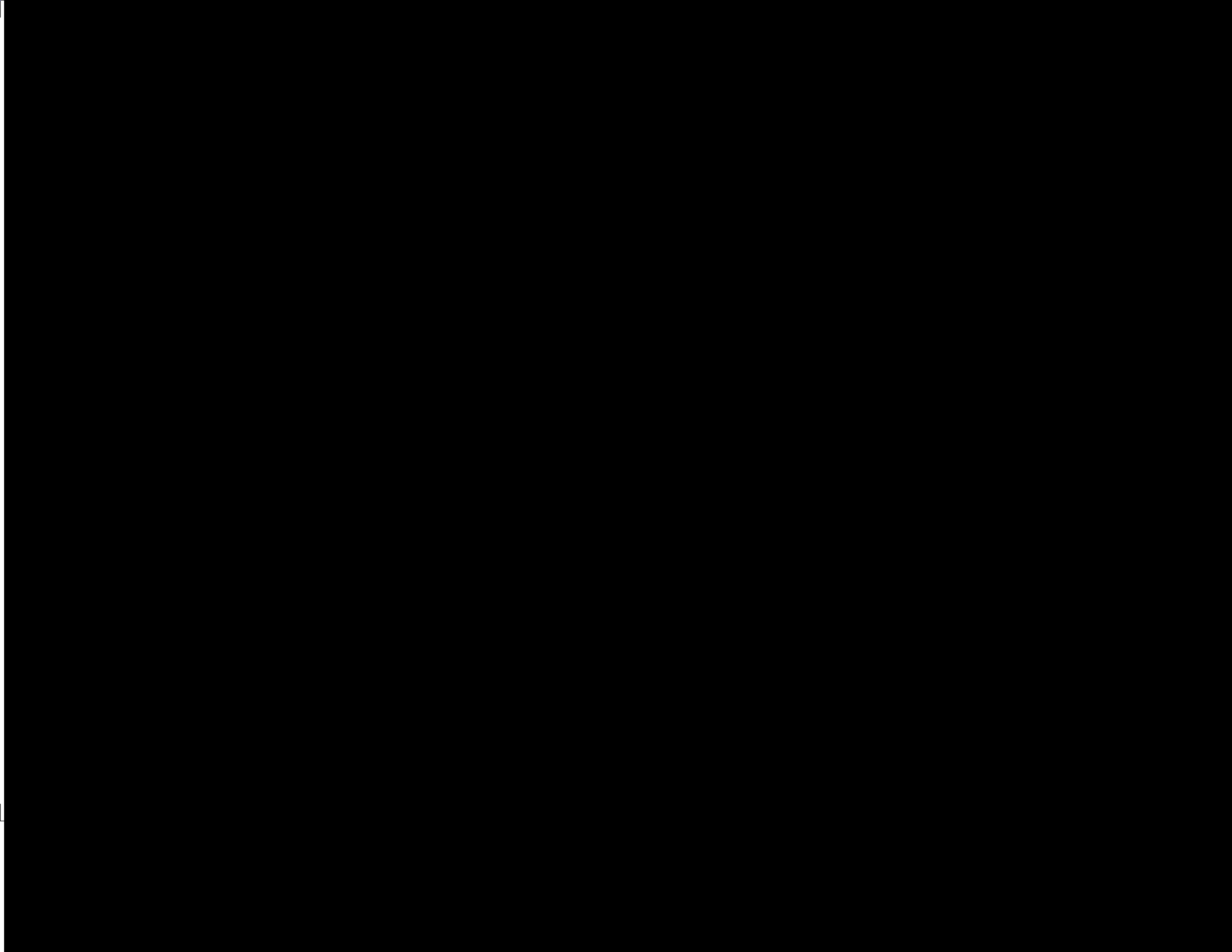
**From:** Matthew Kane <mkane@moss.com>  
**Sent:** Monday, October 13, 2025 12:31 PM  
**To:** Brandon Rodriguez; Pedro J. Hernandez; LBARRET\_CU; Serge Leblanc; Connor Nitterauer; Will Lozano  
**Cc:** John-James Yancey; Jimmy Lorenzo; Tiago Lima; James Pope  
**Subject:** FPH - Power and Data Relocations  
**Attachments:** 60639620\_Room 1607\_1503\_Electrical\_TV Updates\_REV\_2025.10.08.pdf; 60639620\_Copier Location\_3rd Floor\_2025.09.12.pdf

Team, see attached for review and pricing

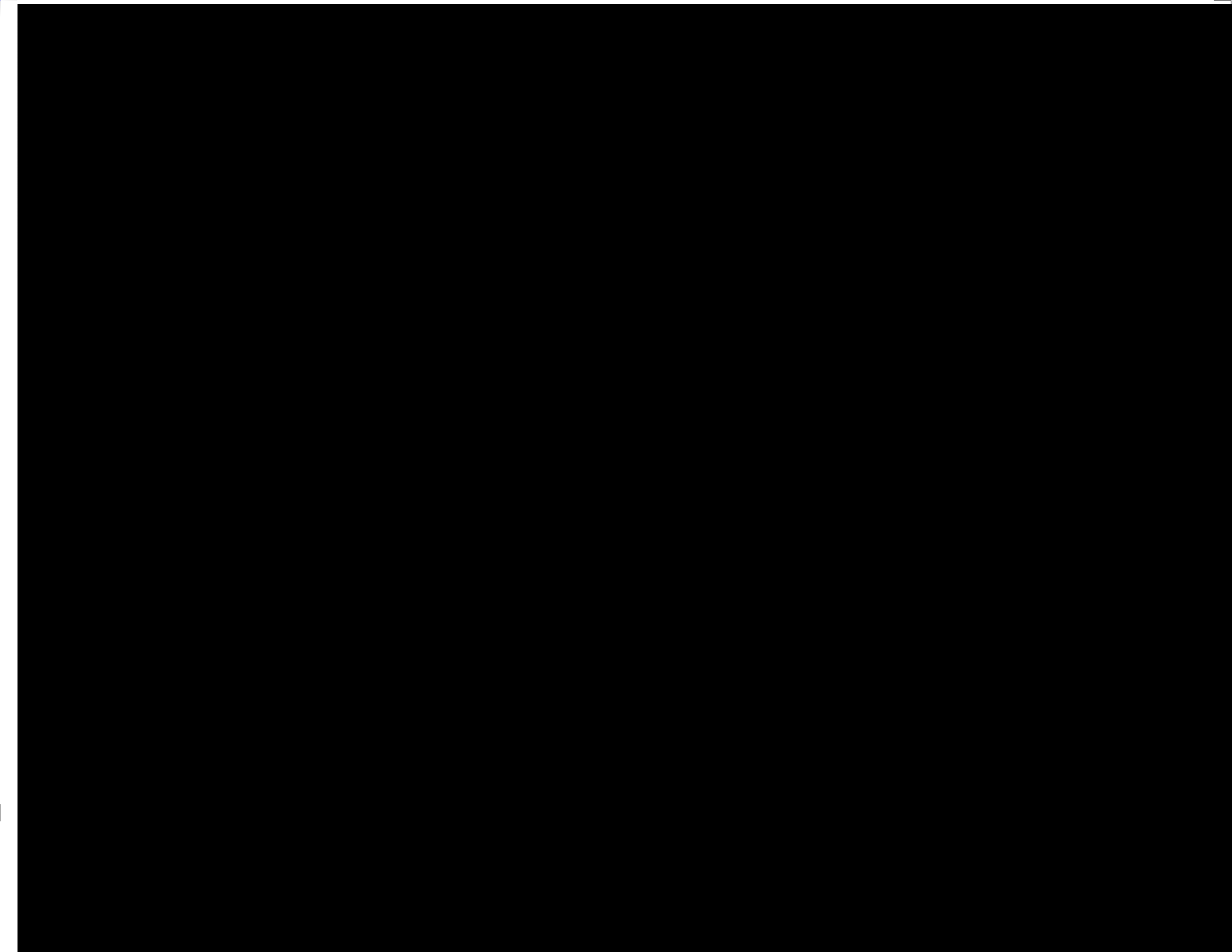
Matthew Kane  
Project Manager  
**Moss**  
Cell: 321.427.3500  
[moss.com](http://moss.com)

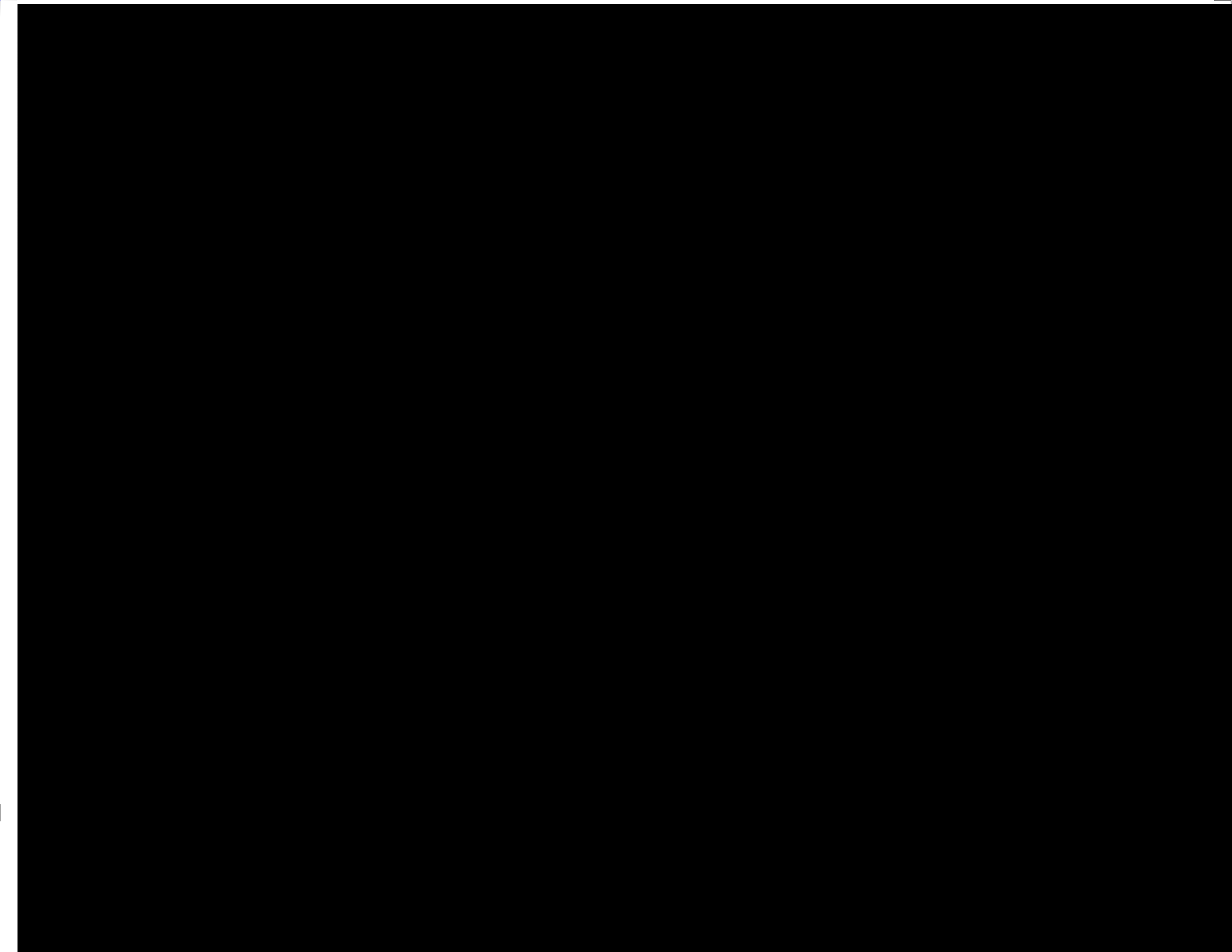


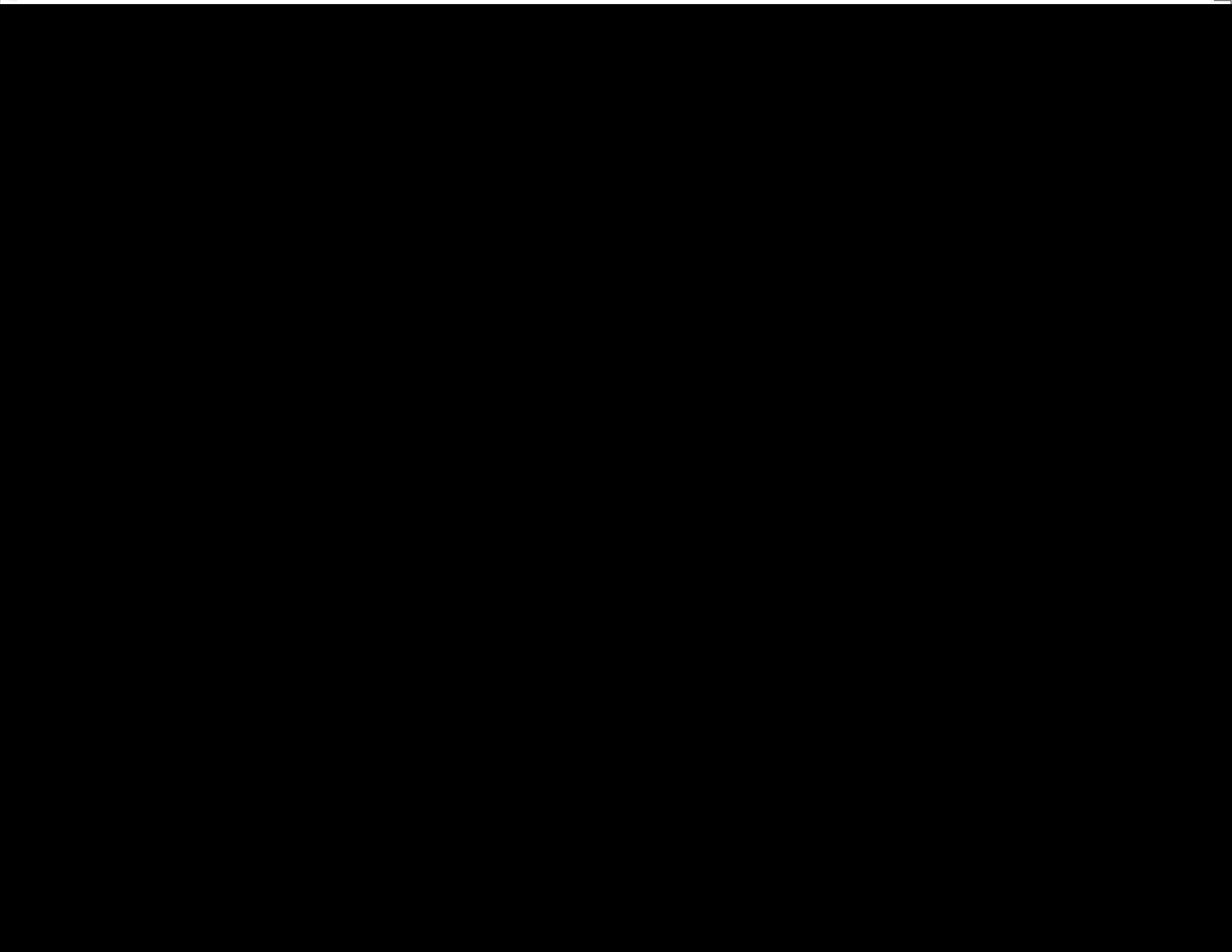














## Lotspeich Co. of Florida, Inc.

<p><b>Broward Office:</b>          6351 N.W. 28th Way, Suite A          Ft. Lauderdale, FL 33309          Phone: (954) 978-2388          Fax: (954) 978-2387</p>	<p><b>Palm Beach Office:</b>          7435 Central Industrial Drive, Suite A          Riviera Beach, FL 33404          Phone: (954) 848-3040          Fax: (954) 848-9020</p>
--	---

website: www.lcfinc.com

### Change Request

**To:** Moss & Assoc.

**Number:** 118  
**Date:** 10/17/25  
**Job:** 06-23-6874 FTL Police Headquarters  
**Phone:**

**Description:** DW - Power and Data Relocation

We are pleased to offer the following specifications and pricing to make the following changes:

Description	Price
FTL DW Extra Work	\$2,578.00
FTL DW Material	\$422.00
	Subtotal: <u>\$3,000.00</u>
	<b>Total: <u><u>\$3,000.00</u></u></b>
If you have any questions, please contact me at .	

Submitted by: Connor Nitterauer  
 Lotspeich Co Of Florida, Inc

Approved by: \_\_\_\_\_  
 Date: \_\_\_\_\_

The aforementioned changes to work activity will result in: - additional working days added to the project completion date. Approval of this change order is required by . Approval of this change order after the listed date may result in additional costs and added time. Please note any exclusions or qualifications listed above. In addition, we reserve the right to quote on all costs that may be unforeseen at this time.

**Conditions Tab**  
**Power and Data Relocation**  
Bid No.304

No	Name	Type	Height	Area	Quantity	Unit Price	Total
1	Patches	(unassigned)	0"		6 EA	500.04	<b>3,000</b>
<b>Quick Sum (1 condition) = 3,000.24</b>							



15461 SW 12th Street, Suite 105  
Sunrise, FL 33326  
Phone: (305) 364-5092  
Fax: (239) 939-1543

Submitted to: Moss & Associates, LLC  
2101 N Andrews Ave  
Ft. Lauderdale, FL 33311

Phone: 408-854-9042

Attn: Matthew Kane

Date: October 21, 2025

### Ft Lauderdale Police HQ

Per plans and specifications, Service Contracting Solutions proposes the following scope of work and pricing for the above referenced project.

#### ADDENDA RECEIVED:

Email sent 9.10.2025

#### SCOPE OF WORK - REPAINT FOR DATA RELOCATION

1. Spot prime gypsum board walls to areas listed below, and apply 2 coats of Pro mar 200 0-Voc Eggshell.

- South & East walls of Room #1607
- North & South walls in Room #1503
- East wall in Room #3112
- South wall in Room #3117
- North wall in Room #3200

#### COST BREAKOUT:

LABOR 24 HRS @ \$50.00 PER = \$1,200  
MATERIALS - 4 GALS. PRO MAR 200 PRIMER @ \$14.06 PER = \$56  
MATERIALS - 10 GALS. PRO MAR 200 EGGSHELL @ \$13.65 PER = \$137  
SALES TAX ON MATERIALS (7%) = \$13  
OH&P MARKUP (10%) = \$141

**TOTAL: \$1,547**

#### EXCLUSIONS & QUALIFICATIONS:

1. All prices on this quotation are valid for 30 days.
2. For P&P Bond, add 2%.

For Buy-out questions call:

SERVICE CONTRACTING SOLUTIONS

*Willbur Lozano*

Project Manager  
15461 SW 12th Street, Suite 105  
Sunrise, FL 33326  
786-424-8826 CELL  
305-364-5092 OFFICE

[E-mail: will@servicecontracting.com](mailto:will@servicecontracting.com)

[Web Site: www.servicecontracting.com](http://www.servicecontracting.com)



RFI#  
 Project Name: FLPD  
 Project Number: 23-414  
 Page Number: 1  
 Change Order #: 69R1  
 Change Order Date: 5/1/2006

**Moss**  
 2101 N ANDREWS AVE  
 FT LAUDERDALE, FL 33311  
 Telephone: (954) 524-5678

**Scope of work**

At the request of ownership, this change order proposal covers the labor and materials required to add electrical and low voltage outlets necessary for converting Room 1503 Storage room into an office space. Please see the details below for reference.

- HQ-E2-2-1CR5:  
 -(2) RM 1503 - 20A 125V DUP REC (MC CABLE - METAL STUD)  
 -RM 1503 - BRANCH JUMPER MC CABLE ROUTE FROM EXISTING RECEPTACLE LENGTH: 56.45'  
 -(3) FINISHED AREA PROTECTION PREP

- HQ-T2-1-1CR2:  
 -(1) RM 1503 - DATA DROP OUTLET ROUGH-IN  
 -(1) RM 1503 TO 1500 - LV 2" SLEEVE  
 -(3) FINISHED AREA PROTECTION PREP

**This change order excludes the following work:**

- Demolition or removal of completed millwork.
  - Repair, patching, or painting/finishing of any surface impacted by the conduit and or box rough in needed to complete this work.
  - Concrete back filling.
  - Any A/V equipment, terminations, or final device installation to be done by others.
  - Any low voltage cabling, terminations, or free wire cabling support by LV trade partner. (JADE/JCI scope only)
  - Ceiling or access tile removal/replacement outside normal conduit and box scope.
  - Specialty or custom box/enclosure and or finish plates by others.
- All remedial or repair work necessary due to these changes is to be performed by others.

**Summary**

**MATERIAL**

General Materials		509.21
Material Tax	(@ 7.000 %)	35.64

**Material Total** **544.85**

**LABOR**

ELECTRICIAN	(26.30 Hrs @ \$55.00)	1,446.50
FOREMAN	(5.08 Hrs @ \$65.00)	330.20
SUPERINTENDENT	(2.03 Hrs @ \$70.00)	142.10

Phone: 305-669-1776 Fax: 305-669-1710



RFI#  
**Project Name:** FLPD  
**Project Number:** 23-414  
**Page Number:** 2  
**Change Order #:** 69R1  
**Change Order Date:** 5/1/2006

**Moss**  
 2101 N ANDREWS AVE  
 FT LAUDERDALE, FL 33311  
 Telephone: (954) 524-5678

---

**Summary (Cont'd)**

PROJECT MANAGER	(0.61 Hrs @ \$85.00)	51.85
BIM COORDINATION	(0.61 Hrs @ \$55.00)	33.55
ESTIMATING	(3.00 Hrs @ \$55.00)	165.00
AS-BUILT DRAWINGS	(3.00 Hrs @ \$55.00)	165.00
		<hr/>
<b>Total Labor</b>		<b>2,334.20</b>
		<hr/>
<b>TOTAL MATERIAL, LABOR &amp; EQUIPMENT</b>		<b>2,879.05</b>
		<hr/>
OH&P	(@ 10.000 %)	287.91
		<hr/>
<b>Final Amount</b>		<b>\$3,166.96</b>



**Moss**  
 2101 N ANDREWS AVE  
 FT LAUDERDALE, FL 33311  
 Telephone: (954) 524-5678

**Project Name:** FLPD  
**Project Number:** 23-414  
**Page Number:** 3  
**Change Order #:** 69R1  
**Change Order Date:** 5/1/2006

**Itemized Breakdown**

**HQ-E2-2-1C REV 5**

Description	Qty	Net Price U	Total Mat.	Labor U	Total Hrs.
GROUND SCREW W/ INSUL #12 LEAD	2	503.57 C	10.07	3.75 C	0.07
#8x 1/2 WAFER HEAD SHEET MTL SCREW	12	6.04 C	0.72	1.88 C	0.23
#12/2C CABLE MC - ALUM ARMOR	44	862.08 M	37.93	19.00 M	0.84
#10/2C CABLE AC-90 - STL ARMOR	62	1,838.56 M	113.99	26.25 M	1.63
3/8" CONN SADDLEGRIP DC FOR FLEX / AC-90 / MC	4	98.42 C	3.94	7.50 C	0.30
NMC OR MC/AC SUPPORT TO WOOD OR MTL STUD	2	71.86 C	1.44	6.25 C	0.13
CABLE/CONDUIT ANTI-RATTLE SUPPORT FOR MTL STU	8	48.44 C	3.88	5.00 C	0.40
WIRE CONN RED	8	19.64 C	1.57	4.00 C	0.32
1G DECORATOR PLATE - PLASTIC IVY	2	138.50 C	2.77	3.75 C	0.07
20A 125V DUP REC - DECOR IVY (SG)	2	1,560.00 C	31.20	25.00 C	0.50
ULINE INDOOR PLASTIC PROTECTOR (12' x 400')	3	36.00 E	108.00	0.75 E	2.25
3M 2090 PAINTER'S MASKING TAPE (2" x 60 YDS)	3	8.99 E	26.97	0.75 E	2.25
RETRO FITTING BOX CUT/DEMO	2	0.00 E	0.00	1.00 E	2.00
RETRO FITTING CUT IN BOXES W/ EARS (SINGLE GANG)	2	13.43 E	26.86	0.25 E	0.50
REMOVAL OF CEILING TILE	3	0.00 E	0.00	0.25 E	0.75
<b>Totals</b>	<b>159</b>		<b>369.34</b>		<b>12.23</b>

**HQ-T2-1-1C REV 2**

Description	Qty	Net Price U	Total Mat.	Labor U	Total Hrs.
2" SLEEVE	1	0.00 E	0.00	0.31 E	0.31
1/8" POLYTWINE	10	11.94 M	0.12	3.75 M	0.04
ULINE INDOOR PLASTIC PROTECTOR (12' x 400')	3	36.00 E	108.00	0.75 E	2.25
3M 2090 PAINTER'S MASKING TAPE (2" x 60 YDS)	3	8.99 E	26.97	0.75 E	2.25
2" SLEEVE DEMO IN DRYWALL	1	0.00 E	0.00	1.00 E	1.00
RETRO FITTING BOX CUT/DEMO	1	0.00 E	0.00	1.00 E	1.00
NON-METALLIC LOW-VOLTAGE MOUNTING BRACKET (SI	2	2.39 E	4.78	0.25 E	0.50
REMOVAL OF CEILING TILE	3	0.00 E	0.00	0.25 E	0.75
<b>Totals</b>	<b>24</b>		<b>139.87</b>		<b>8.10</b>

**CLIENT ACCEPTANCE**



**Moss**  
2101 N ANDREWS AVE  
FT LAUDERDALE, FL 33311  
Telephone: (954) 524-5678

**Project Name:** FLPD  
**Project Number:** 23-414  
**Page Number:** 4  
**Change Order #:** **69R1**  
**Change Order Date:** 5/1/2006

<b>Name:</b> _____
<b>Date:</b> _____
<b>Signature:</b> _____ I hereby accept this quotation and authorize the contractor to complete the above described work.

## Brandon Rodriguez

---

**From:** Brandon Rodriguez  
**Sent:** Thursday, September 11, 2025 10:47 AM  
**To:** Angel Lopez; John-James Yancey; Jimmy Lorenzo; D'von Nottage; Matthew Kane  
**Cc:** Pedro J. Hernandez; Fernando Munilla  
**Subject:** RE: FLPH - Changes to RM 1503

Morning Angel,

Received, Thunder will provide pricing before end of day tomorrow. As discussed over the phone we will price accordingly similar to the AV-IT provisions (cut in retro fitting boxes).

Thanks,

**Brandon Rodriguez**

Thunder Electrical Contractors Inc.



7035-F SW 47 St., Miami, FL 33155  
M:786-920-3582 - O:305-669-1776  
E: brandon@thunder-electric.com

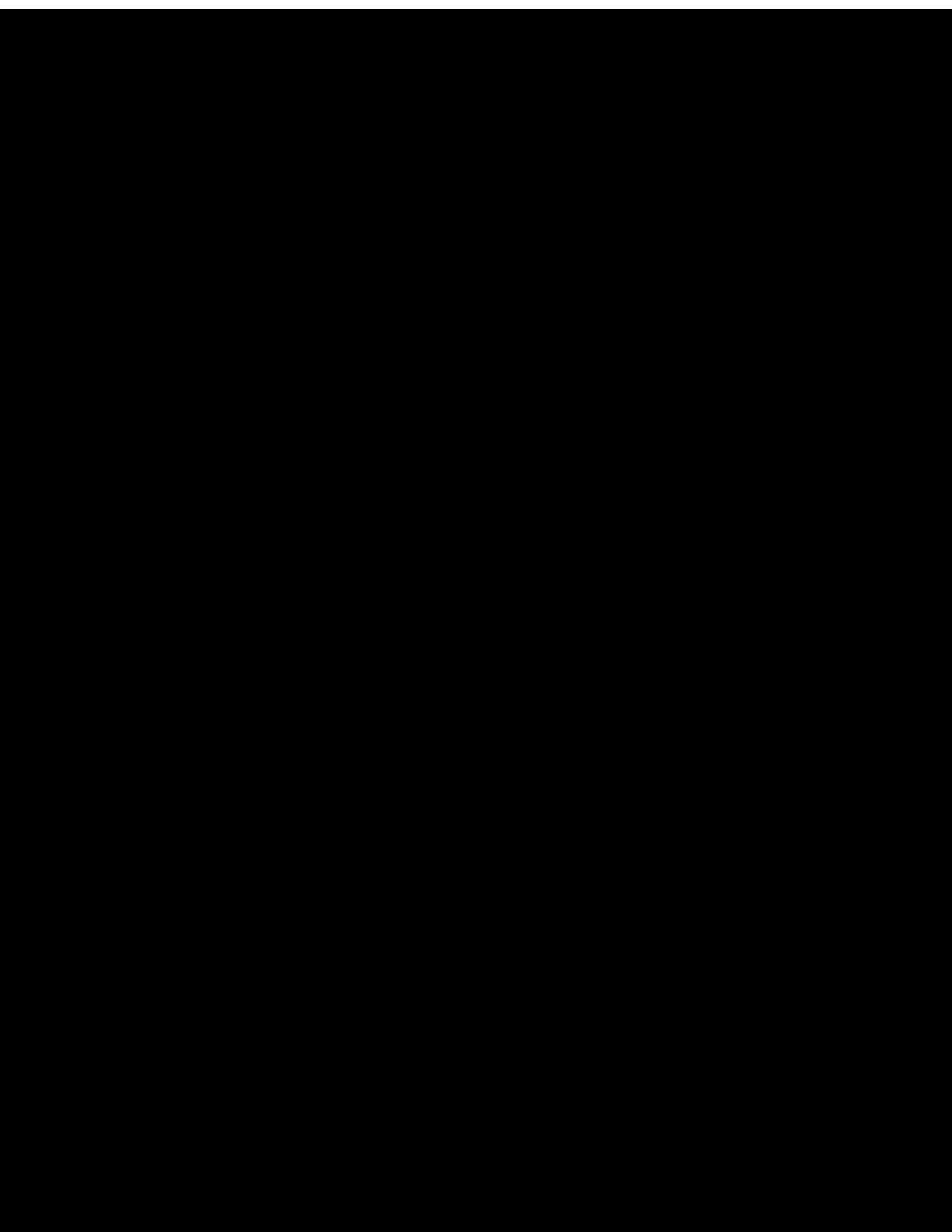
---

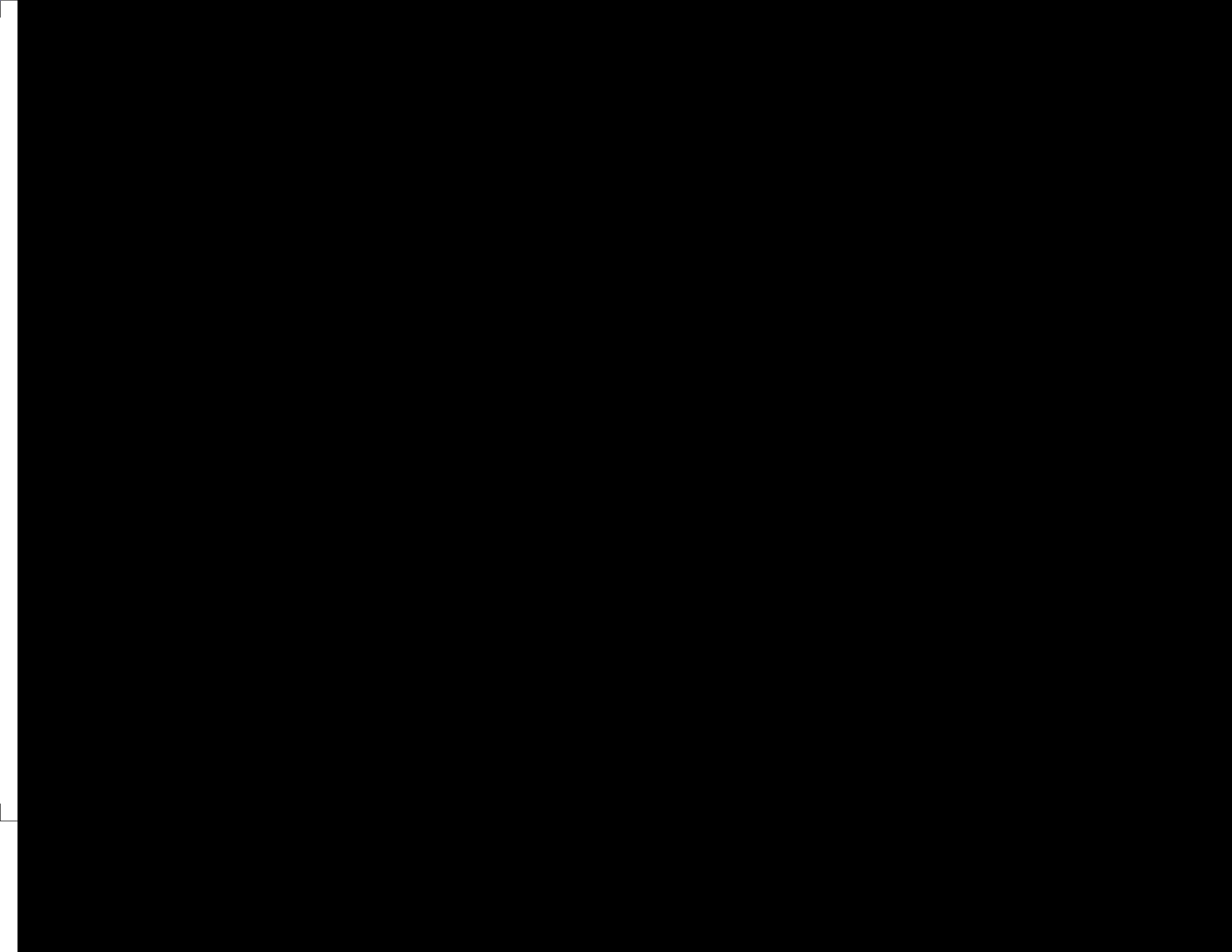
**From:** Angel Lopez <alopez@moss.com>  
**Sent:** Thursday, September 11, 2025 9:14 AM  
**To:** Brandon Rodriguez <brandon@thunder-electric.com>; Pedro J. Hernandez <pedro@thunder-electric.com>; LBARRET\_CU <Laxleyb@jade-com.com>; Serge Leblanc <sergel@jade-com.com>; John Spera <johns@jade-com.com>; Connor Nitterauer <connor.nitterauer@lcfinc.com>; Mike Miller <mike.miller@lcfinc.com>  
**Cc:** D'von Nottage <dnottage@moss.com>; Jimmy Lorenzo <jlorenzo@moss.com>; John-James Yancey <jjyancey@moss.com>  
**Subject:** FLPH - Changes to RM 1503

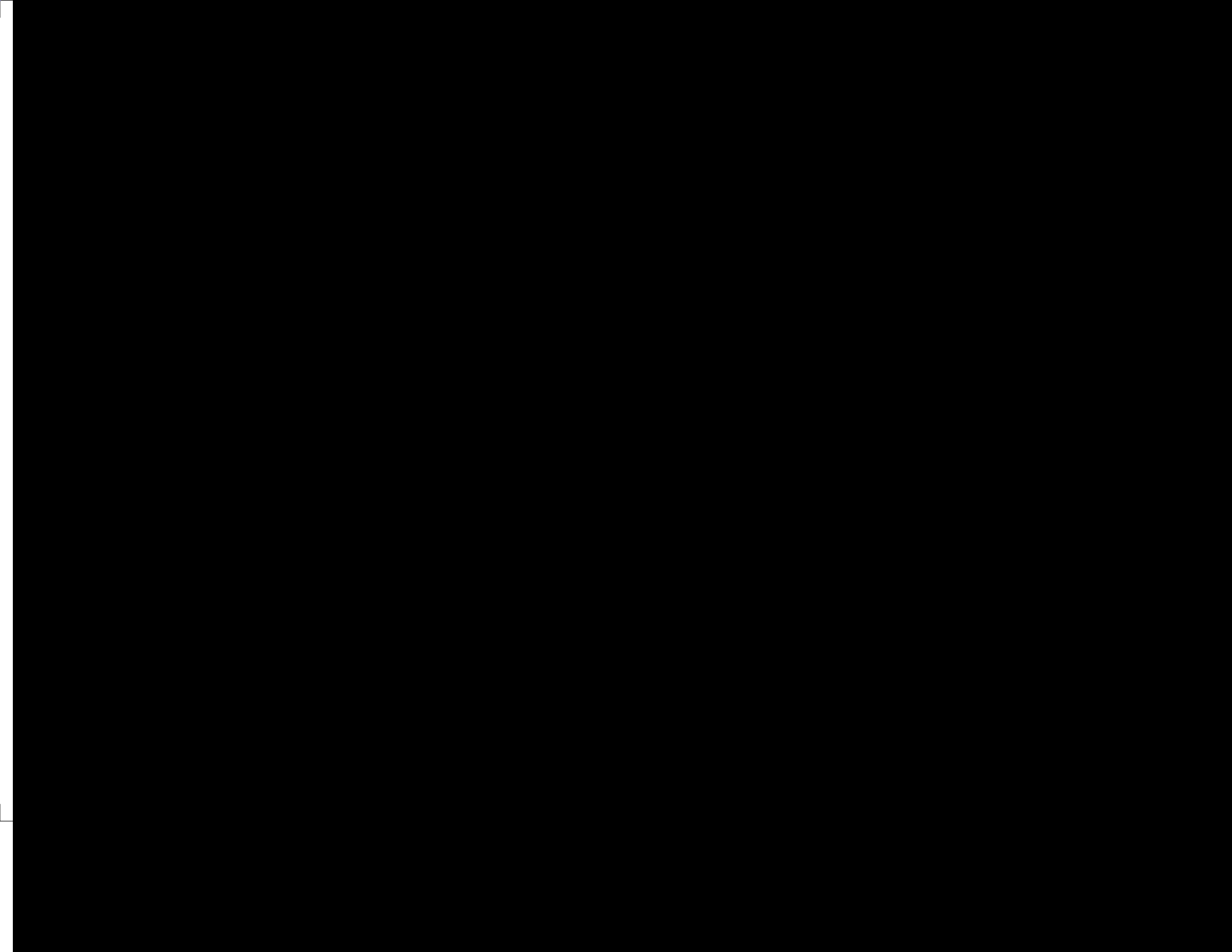
Team,

Ownership would like to turn 1503 into an office and they've requested pricing to add two receptacles on the north and south walls and a data jack to match the layout of the other offices in the vicinity.

Please let me know if you have any questions.









**Moss & Associates, LLC**  
 6363 NW 6th Way  
 Ft Lauderdale, FL 33309

May 04, 2026

Ronald Stein  
 City of Fort Lauderdale  
 101 NE 3rd Ave, Suite 2100  
 Ft. Lauderdale, FL 33301

RE: Potential Change Item (PCI) 0357 Notification  
 Fort Lauderdale Police Headquarters - B372302

Dear Ronald Stein,

This letter is to provide official notification of a potential change item (PCI) as follows:

PCI Number: 0357  
 Date: December 04, 2025  
 Description: Shooting Range Lighting Control  
 Days Requested:  
 Reason: Owner Directive - External  
 Scope Description: Shooting range lighting control Option #2 per PD request.

This PCI is comprised of the following items:

Shooting Range Lighting Control Option #2	\$ 12,044.16
01 Subcontract Default Insurance 1.25%	\$ 150.55
02 Moss Insurance 1.75%	\$ 210.77
03 Bond 1%	\$ 120.44
04 Fee 4%	\$ 481.77

<b>Grand Total</b>	<b>\$13,007.69</b>
--------------------	--------------------

Per the terms and conditions of our contract, we have attached the appropriate back up documentation to substantiate the above referenced costs. This request only includes the items specifically identified in this change proposal. All other costs associated with this project shall be submitted under a separate change order cover.

The costs associated with this PCI will remain valid for fourteen (14) calendar days after submission.

Please indicate your formal approval for this additional work and cost by signing in the space provided below. Moss & Associates will then incorporate this change into the next Owner Change Order (OCO).

If you should have any questions, please contact the undersigned at 954-326-2727 as soon as possible.

<p>Sincerely,  <b>Moss &amp; Associates, LLC</b></p> <p>_____ Date: _____</p> <p>Matthew Kane          Sr. Project Manager</p>	<p>Reviewed / Approved by:  <b>City of Fort Lauderdale</b></p> <p><b>Approved:</b> _____ <b>Date:</b> _____          (Owner)</p>
--	--



**RFI#**  
**Project Name:** FLPD  
**Project Number:** 23-414  
**Page Number:** 1  
**Change Order #:** 75R1  
**Change Order Date:** 5/4/2026

**Moss**  
2101 N ANDREWS AVE  
FT LAUDERDALE, FL 33311  
Telephone: (954) 524-5678

---

### Scope of work

---

At the request of ownership, this change order proposal covers the labor and materials associated with the requested changes to the changes in the shooting range lighting. The request includes separating the lighting into (3) separate zones:

- 25 yard line light, specifically circuit 10 lighting fixtures (West),
- Circuit 8 lighting fixtures (East)
- Circuit 6 lighting fixtures (West)

All zones will be independently controlled and dimmed. These changes were requested during a coordination meeting held on September 18, 2025, with Moss, the Design Team, Power and Lighting Control Design, and Thunder Electric.

The existing lighting control system and fixtures are currently configured to operate as a single zone, controlled and dimmed by one (1) switch.

The request also included (3) separate control equipment schemes:

Option 1 - Control switches in shooting range only (**deduct alternate of \$1,878.57**)

Option 2 - Control switches in shooting range and duplicate switches in range officer room (**deduct alternate of \$2,035.71**)

Option 3 - Control switches in shooting range and touch panel in range room office. (**Considered in total**)

To implement these changes, the existing lighting control system will need to be partially demolished and reconfigured. New cable routing will be required from each zone back to the power pack devices, which are accessible in the ceiling grid area at the East end of the shooting range. The existing switch will need to be removed and replaced with a new 4PDA switch. Demolition of a section of the south wall and coring through to the west wall of the control room will be necessary to install the additional box, conduit, and sleeve provisions for the requested touch panel.

Terminations, testing, and coordination required to provide a fully functional and properly zoned lighting control system, in accordance with the revised design intent, are included in this change order.

World Electric's quote reflects three pricing options per Owner's request. Please ensure the delta pricing is adjusted to align with our proposal for the desired option.

### **This change order excludes the following:**

- Demolition or removal of completed millwork.
- Repair, patching, or painting/finishing of any surface impacted by the conduit and or box rough in needed to complete this work.
- Concrete back filling.
- Any A/V equipment, terminations, or final device installation
- Any low voltage cabling, terminations, or free wire cabling support by LV trade partner.
- Ceiling or access tile removal/replacement outside normal conduit and box scope.
- Specialty or custom box/enclosure and or finish plates by others.
- Any terminations into action targets system to be done by others.

**All remedial or repair work necessary due to these changes is to be performed by others.**

---

### Summary

---



RFI#  
**Project Name:** FLPD  
**Project Number:** 23-414  
**Page Number:** 2  
**Change Order #:** 75R1  
**Change Order Date:** 5/4/2026

**Moss**  
 2101 N ANDREWS AVE  
 FT LAUDERDALE, FL 33311  
 Telephone: (954) 524-5678

---

**Summary (Cont'd)**

---

**MATERIAL**

General Materials		1,324.14	
WORLD ELECTRIC		2,557.14	
Material Tax	(@ 7.000 %)	271.69	
			<hr/>
<b>Material Total</b>			<b>4,152.97</b>

**LABOR**

ELECTRICIAN	(89.02 Hrs @ \$55.00)	4,896.10	
FOREMAN	(20.88 Hrs @ \$65.00)	1,357.20	
SUPERINTENDENT	(8.35 Hrs @ \$70.00)	584.50	
PROJECT MANAGER	(2.51 Hrs @ \$85.00)	213.35	
BIM COORDINATION	(2.51 Hrs @ \$55.00)	138.05	
ESTIMATING	(3.00 Hrs @ \$55.00)	165.00	
			<hr/>
<b>Total Labor</b>			<b>7,354.20</b>

**TOTAL MATERIAL, LABOR & EQUIPMENT**

---

**11,507.17**

OH&P	(@ 10.000 %)		1,158.22
			<hr/>

**Final Amount**

**\$12,740.39**



**Moss**  
 2101 N ANDREWS AVE  
 FT LAUDERDALE, FL 33311  
 Telephone: (954) 524-5678

**Project Name:** FLPD  
**Project Number:** 23-414  
**Page Number:** 3  
**Change Order #:** 75R1  
**Change Order Date:** 5/4/2026

**Itemized Breakdown**

**FIRING RANGE 1**

Description	Qty	Net Price U	Total Mat.	Labor U	Total Hrs.
2" DIAM CORE 4" THICK WALL	1	0.00 E	0.00	0.00 E	0.00
FIRESTOP COMPOUND CAULK (1) PIPE	1	1.00 E	1.00	0.06 E	0.06
3/4" CONDUIT - EMT	34	154.78 C	52.63	4.40 C	1.50
3/4" CONN SS STL - EMT	1	228.82 C	2.29	12.50 C	0.13
3/4" COUPLING SS STL - EMT	1	268.91 C	2.69	0.00 C	0.00
3/4" INSULATING BUSHING - EMT	2	27.42 C	0.55	5.00 C	0.10
1/2 OR 3/4" SNAP CLOSE CLIP - SIDE MNT TO MTL STUD	2	178.59 C	3.57	9.00 C	0.18
4x 1 1/2" SQ BOX COMB KO W/ FLUSH MTL STUD BRKT	1	1,960.60 C	19.61	28.75 C	0.29
4" SQ 1G PLSTR RING 5/8" RISE	1	937.62 C	9.38	3.13 C	0.03
4 11/16x 2 1/8" SQ BOX COMB KO	4	2,821.85 C	112.87	31.25 C	1.25
4 11/16" SQ BLANK COVER	4	811.06 C	32.44	3.13 C	0.13
1/4-20 MACHINE SCREW ANCHOR	4	29.24 C	1.17	10.00 C	0.40
1/4" THREADED ROD - PLTD	12	68.72 C	8.25	3.13 C	0.38
1/4-20 HEX NUT - PLTD STL	8	3.14 C	0.25	2.50 C	0.20
1/4" FLAT WASHER - PLTD STL	8	2.92 C	0.23	1.25 C	0.10
3/16x 1 1/4 CONCRETE SCREW HEX HEAD - BLUE	4	45.53 C	1.82	8.50 C	0.34
3.62" Lx 0.091" W - 0.625" BUNDLE NYLON CABLE TIE - ST	26	18.10 C	4.71	3.75 C	0.97
#8x 1/2 WAFER HEAD SHEET MTL SCREW	6	6.04 C	0.36	1.88 C	0.11
CBL - CMP CAT5e UTP 350-MHz GRN	89	440.00 M	39.16	9.00 M	0.80
1/2" CONN SADDLEGRIP DC FOR FLEX / AC-90 / MC	8	127.70 C	10.22	11.25 C	0.90
CABLE/FLEX WIRE HNGR - UP TO 3 CBL	95	46.63 C	44.30	6.25 C	5.94
1 5/16" LOOP CBL SUPPORT - SIDE MNT TO 1/4" ROD OR	7	337.38 C	23.62	7.50 C	0.53
1/8" POLYTWINE	40	11.94 M	0.48	3.75 M	0.15
DEMO EXISTING INFRASTRUCTURE	1	0.00 E	0.00	15.00 E	15.00
n\$ 4PDA INSTALLATION TO EXISTING	1	0.00 E	0.00	0.50 E	0.50
N TCH DEVICE INSTALLATION	1	0.00 E	0.00	0.50 E	0.50
12/3 SOLID 16/2 SOLID x 250 ft> MC-PCS DUO CABLE	486	1.96 E	952.56	10.00 C	51.03
nPD DEVICE INSTALLATION	4	0.00 E	0.00	0.50 E	2.00
<b>Totals</b>	<b>852</b>		<b>1,324.14</b>		<b>83.50</b>

**CLIENT ACCEPTANCE**



**Moss**  
2101 N ANDREWS AVE  
FT LAUDERDALE, FL 33311  
Telephone: (954) 524-5678

**Project Name:** FLPD  
**Project Number:** 23-414  
**Page Number:** 4  
**Change Order #:** 75R1  
**Change Order Date:** 5/4/2026

<b>Name:</b> _____
<b>Date:</b> _____
<b>Signature:</b> _____ I hereby accept this quotation and authorize the contractor to complete the above described work.

## Brandon Rodriguez

---

**From:** Angel Lopez <alopez@moss.com>  
**Sent:** Thursday, September 11, 2025 9:45 AM  
**To:** Brandon Rodriguez; Pedro J. Hernandez  
**Subject:** RE: FLPH - Requesting Availability for Teams Call for Lighting in Shooting Range

FYI, Ownership is also requesting reps from the lighting vendor for the lights in the shooting range. Is that Power and Lighting?

All the best,  
Angel Lopez  
Senior Project Engineer  
Fort Lauderdale Police Headquarters

**Moss**

Direct: 408.854.9042  
[moss.com](http://moss.com)

---

**From:** Angel Lopez  
**Sent:** Thursday, September 11, 2025 9:44 AM  
**To:** Brian Sanders <brians@actiontarget.com>; Brandon Rodriguez <brandon@thunder-electric.com>; Pedro <pedro@thunder-electric.com>  
**Subject:** FLPH - Requesting Availability for Teams Call for Lighting in Shooting Range

Team,

AECOM and Ownership would like to set up a call to discuss how we can dim the lights in the shooting range at the 5, 10, 20, 25, etc yard lines.

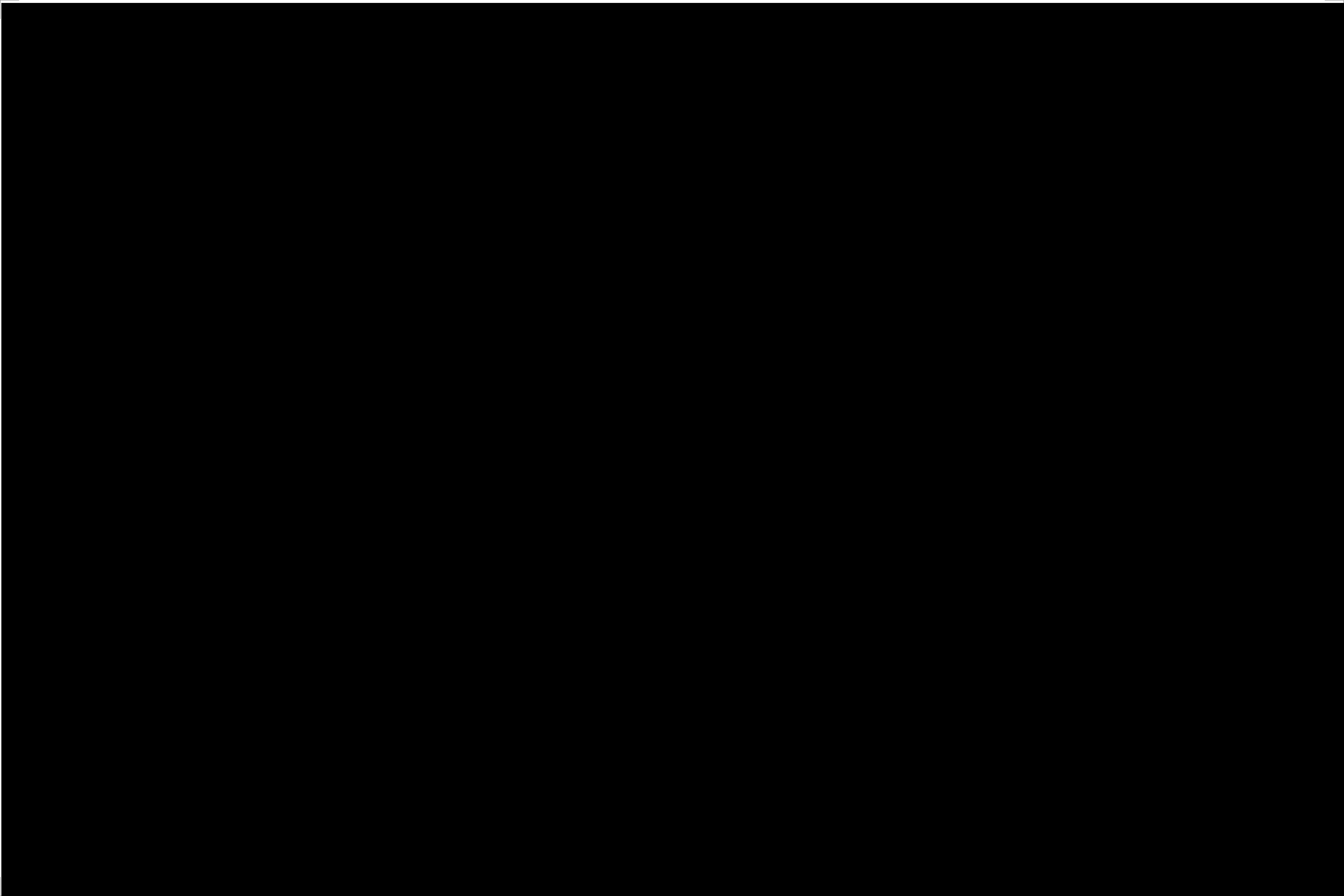
Can you send me your availability for a Teams call next week?

As of now, I'm open Tuesday after 11 AM, Wednesday between 9-12, 1-2, 3-4 and generally available Thursday and Friday.

All the best,  
Angel Lopez  
Senior Project Engineer  
Fort Lauderdale Police Headquarters

**Moss**

Direct: 408.854.9042  
[moss.com](http://moss.com)



**Expiration Date: 10/15/25**

## Quotation

**TO:**  
THUNDER ELECTRICAL CONTRACTORS MIAM  
7035-F SW 47TH ST  
MIAMI, FL 33155-4639

**Project Info:**  
Project: FLPD Firing Range  
Job #: 342096  
Bid Date: 09/30/25  
Bid Time: 02:00 PM EDT  
Quoter: JOHAN SANTOYO

Type	Quantity	Vendor	Description	Unit or Lot#	Unit Price	Ext Price
TAXES NOT INCLUDED QUOTING 3 OPTIONS						
	1		FIRING RANGE #1	OPTION 1	1,878.571	1,878.57
	1		NPP16 D EFP	OPTION 1		
	1		NPODMA 4P DX WH	OPTION 1		
<b>TECH</b>	1		CONTROL SERVICES	OPTION 1		
	1		FIRING RANGE #2	OPTION 2	2,035.714	2,035.71
	1		NPP16 D EFP	OPTION 2		
	2		NPODMA 4P DX WH	OPTION 2		
<b>TECH</b>	1		CONTROL SERVICES	OPTION 2		
	1		FIRING RANGE #3	OPTION 3	2,557.143	2,557.14

**From:**  
WORLD ELECTRIC SUPPLY, LLC.  
SALES 305-436-1500  
2301 NW 107TH AVE  
DORAL, FL 33172-2182  
Printed By: JOHAN SANTOYO  
Thanks ,  
Johan Santoyo  
Sales Representative

**Notes**  
All transactions are subject to and exclusively governed by our Term and Conditions of Sale, which are incorporated herein and available at: <https://www.worldelectricssupply.com/terms#sale>. Additional or conflicting terms are rejected, void, and of no force or effect.

Project: FLPD Firing Range

**Expiration**

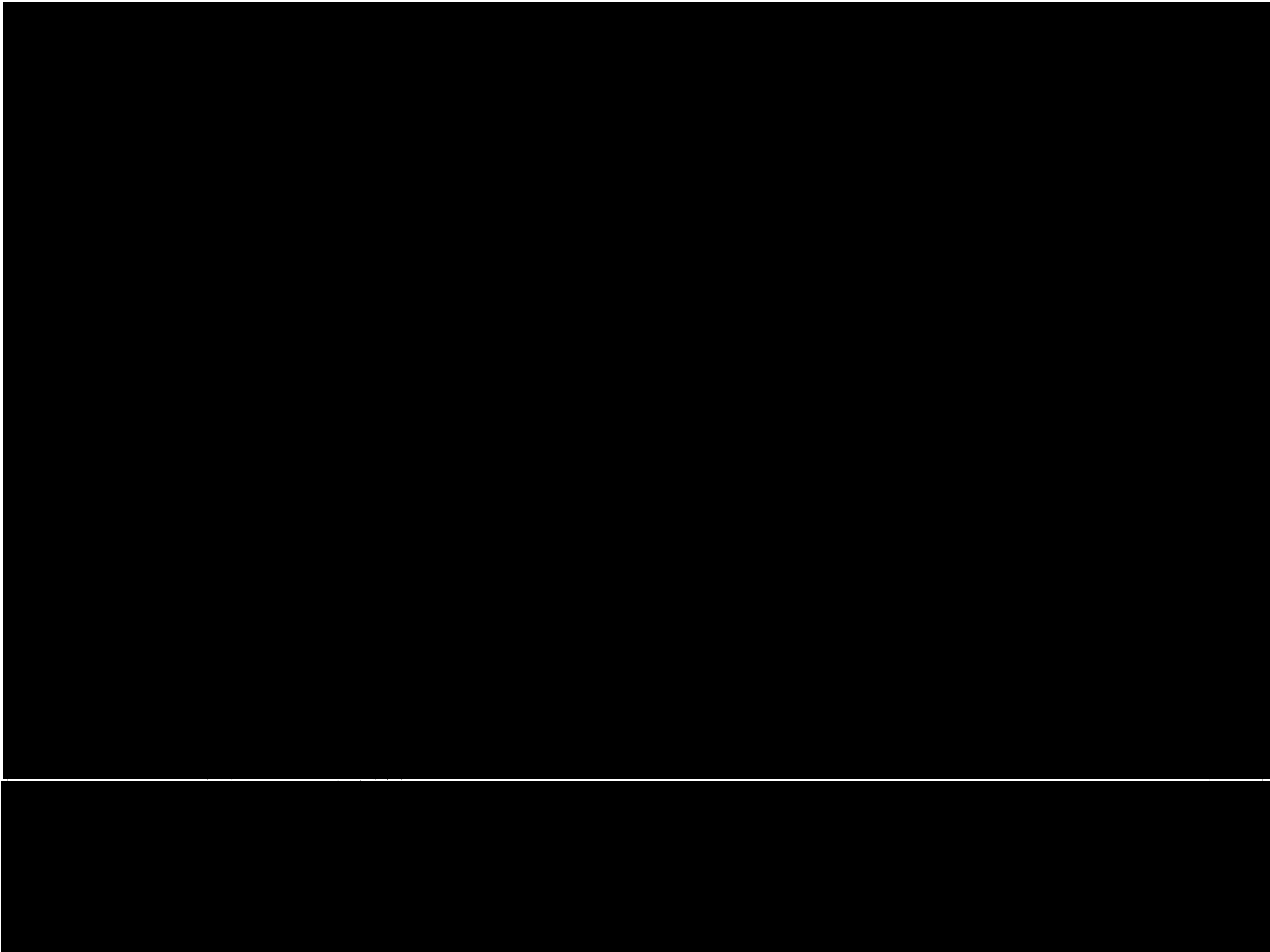
**10/15/25**

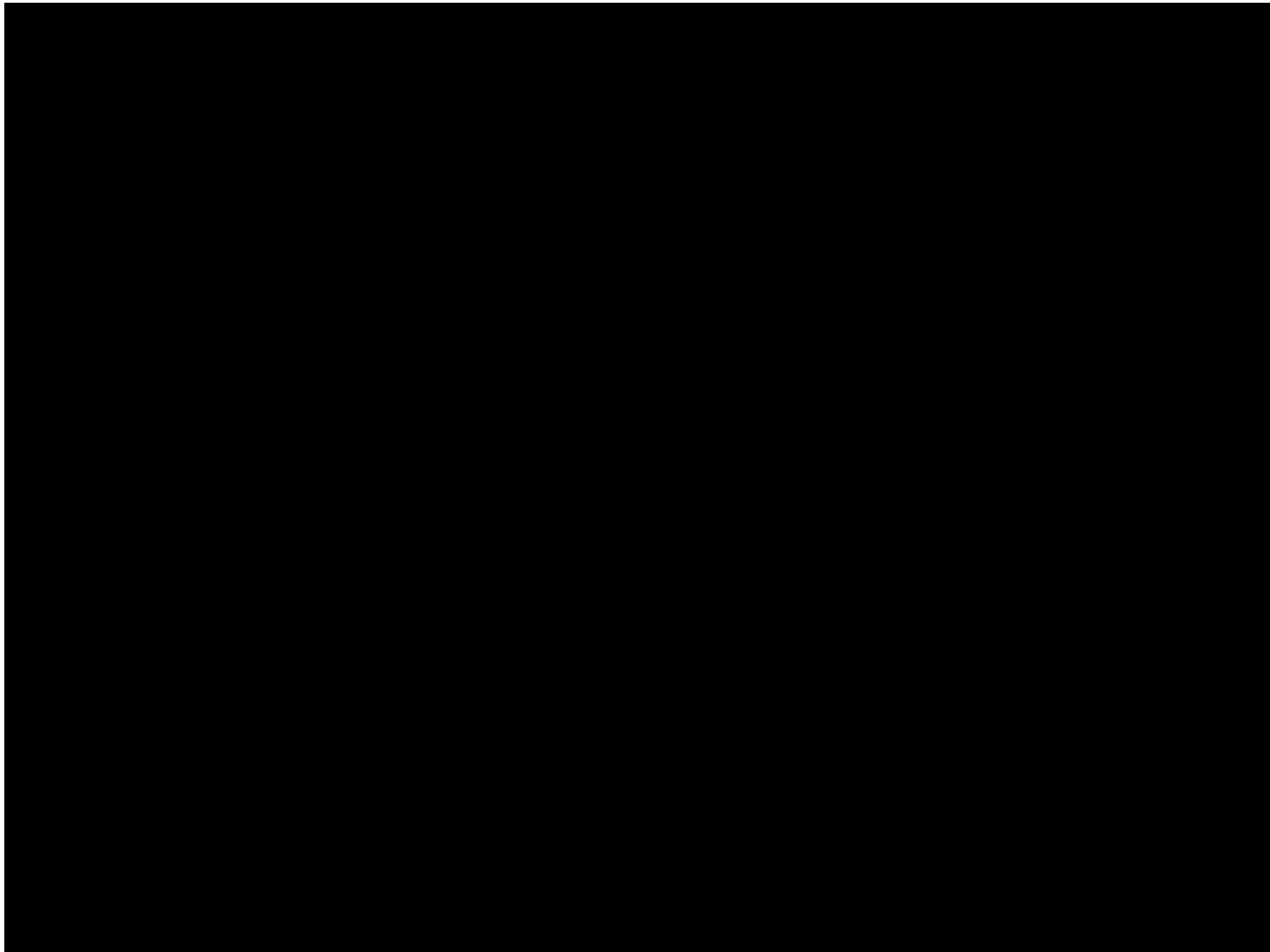
## Quotation

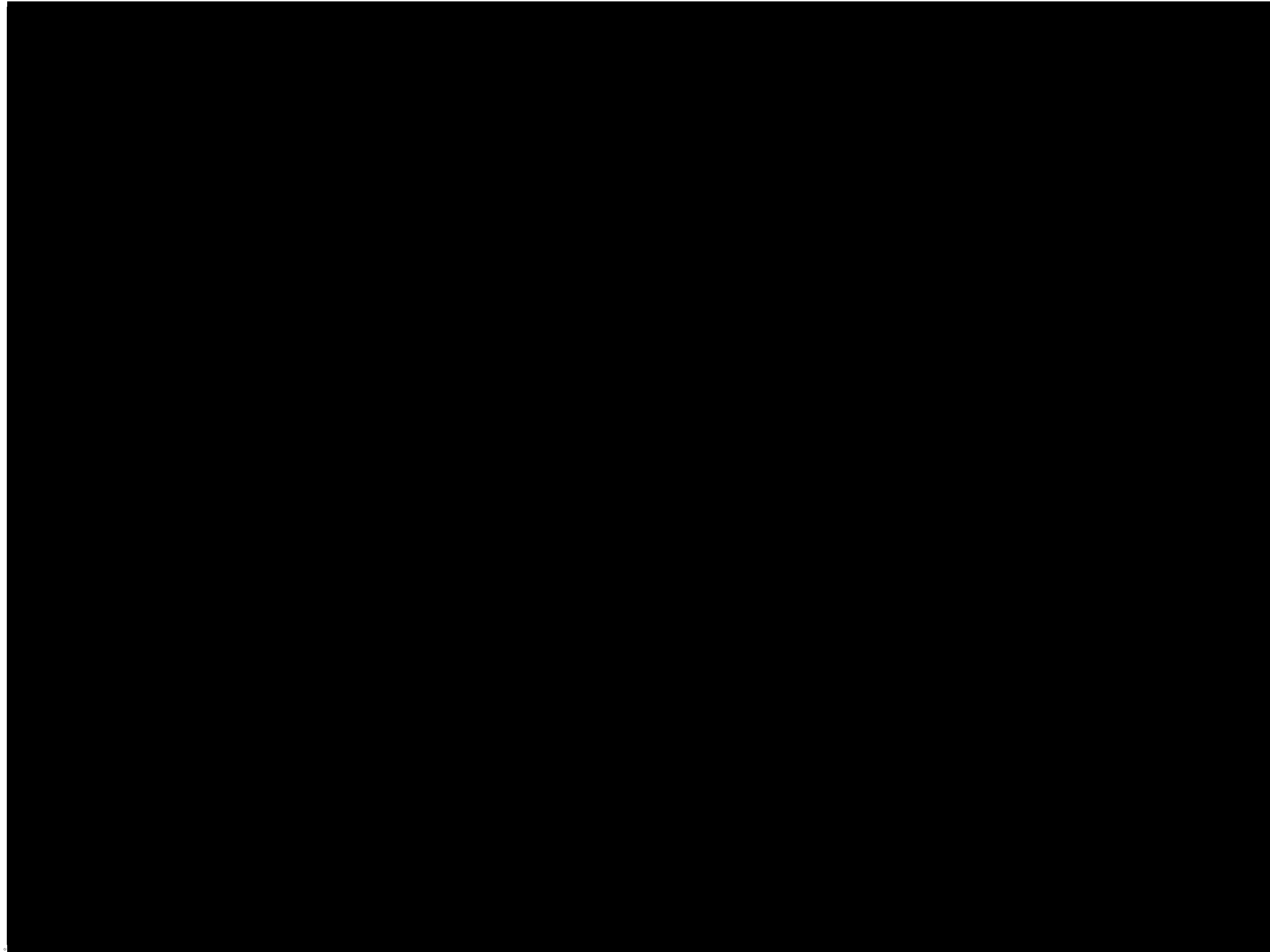
Type	Quantity	Vendor	Description	LOT #	Unit Price	Ext Price
	1		NPP16 D EFP	OPTION 3		
	1		NPODMA 4P DX WH	OPTION 3		
	1		NPOD TOUCH WH	OPTION 3		
<b>TECH</b>	1		CONTROL SERVICES	OPTION 3		

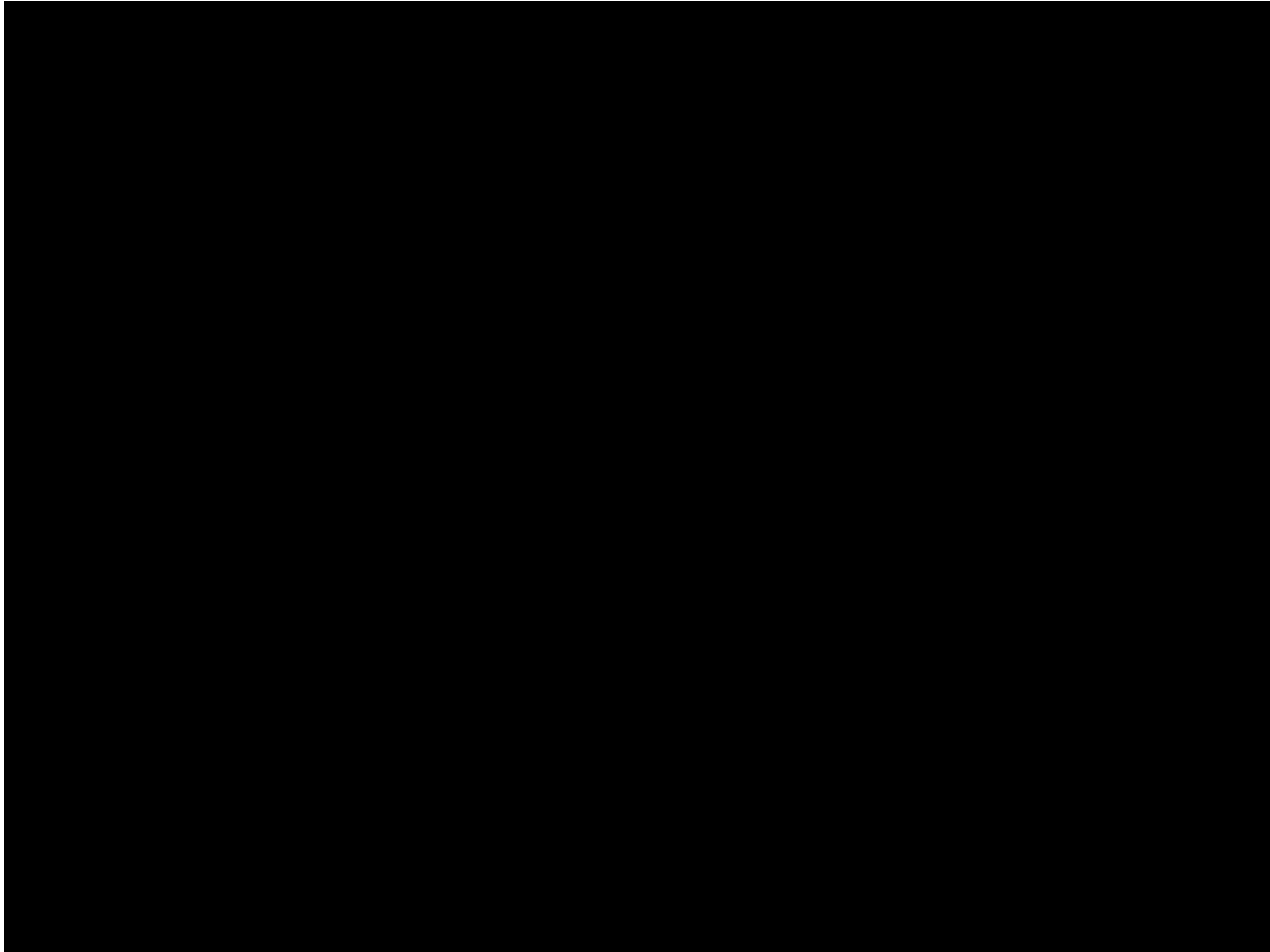
### Terms and Conditions of Sale for Quotes

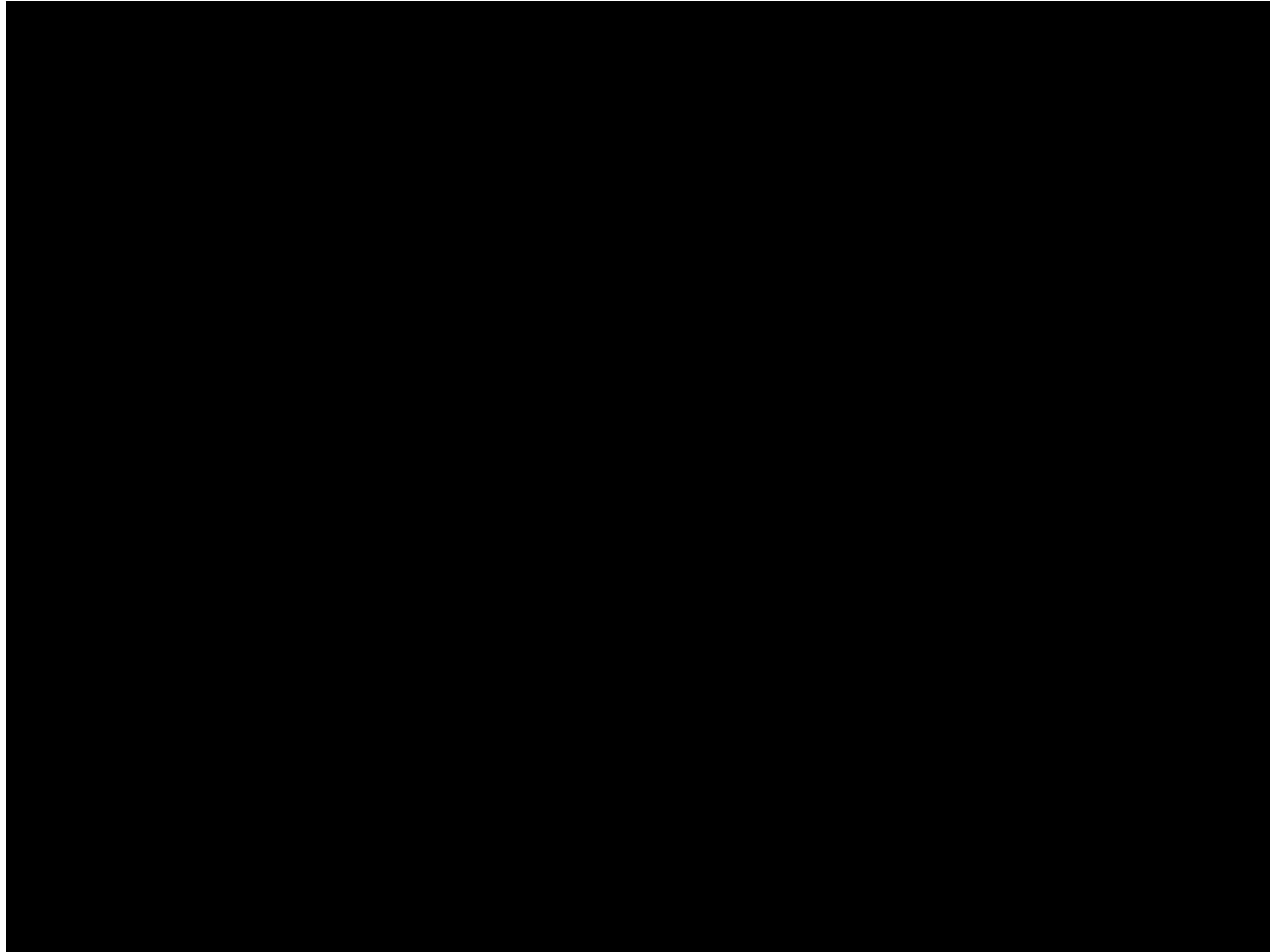
- A. Seller assumes no responsibility whatsoever for any interpretation of bid documents, plans, or specifications provided to Seller (i.e., customer shall be solely responsible for ensuring interpretation of such documents, plans and/or specifications and for conformity and appropriateness of all goods and services ordered in comparison to same).
- B. Prices are subject to change at any time prior to shipment unless otherwise agreed in writing signed by an authorized Seller representative.
- C. Pricing and estimated delivery dates are based solely on the quantities and specific products and/or scope of services identified in this quote. Seller may refuse, terminate, or change pricing, estimated dates, and other terms of its offer if customer requests changes or deviations from the original quote. Unless an authorized Seller representative accepts customer's proposed deviations in an explicit signed agreement modifying this quotation, any such proposed deviations are automatically rejected, void, and of no force or effect.
- D. Quotation does not include special mounting or installation hardware, equipment options, accessories, samples, spares, or mock-up equipment unless otherwise noted.
- E. Seller is not responsible for the design of the project or any goods supplied.
- F. Seller reserves the right to increase the pricing quoted herein to account for force majeure events, the imposition of new or increased tariffs, shipping costs, import/export fees, duties, customs, or taxes, currency fluctuations, or increases in commodity or market pricing.
- G. Pre-shipment of anchor bolts is plus freight.
- H. Where applicable, fabrication and shipment of goods can only be made after Seller receives the following: (i) purchase order conforming to this Quotation, (ii) customer's verification and approval of technical information, (iii) approved Submittal Drawings, and (iv) credit approval.
- I. Lead times are strictly estimates. Seller is not responsible for ship dates beyond estimated dates unless Seller's President or VP Finance otherwise explicitly agrees in a signed writing as part of this Quotation and then only to the extent so agreed.
- J. All orders are FCA Shipping Point, prepaid and billed, unless otherwise noted in quote.
- K. Logistic solutions, storage, handling, kitting, expedited or special delivery, testing, including, but not limited to, infrared scanning and NETA testing, spares, start-up, installation, commissioning, arc flash studies, and other services are excluded unless otherwise specified in this quote. Please contact your Seller representative for additional information on any such services if desired.
- L. This quotation and all related transactions are also subject to the applicable manufacturer's published warranties, including all applicable disclaimers, exclusions, and limitations.
- M. This quotation constitutes Seller's confidential information, and customer shall not share or distribute this quotation to third parties other than to the extent reasonably necessary to process the transactions contemplated herein with Seller.
- N. Unless otherwise expressly agreed in a separate writing signed by Seller's President or VP Finance, Seller does not agree and is not subject to any contractual flow-down or pass-through terms from customer, including, but not limited to, DFARs, FARs, Prime Contracts, Minority Business requirements, Buy America Act, etc.

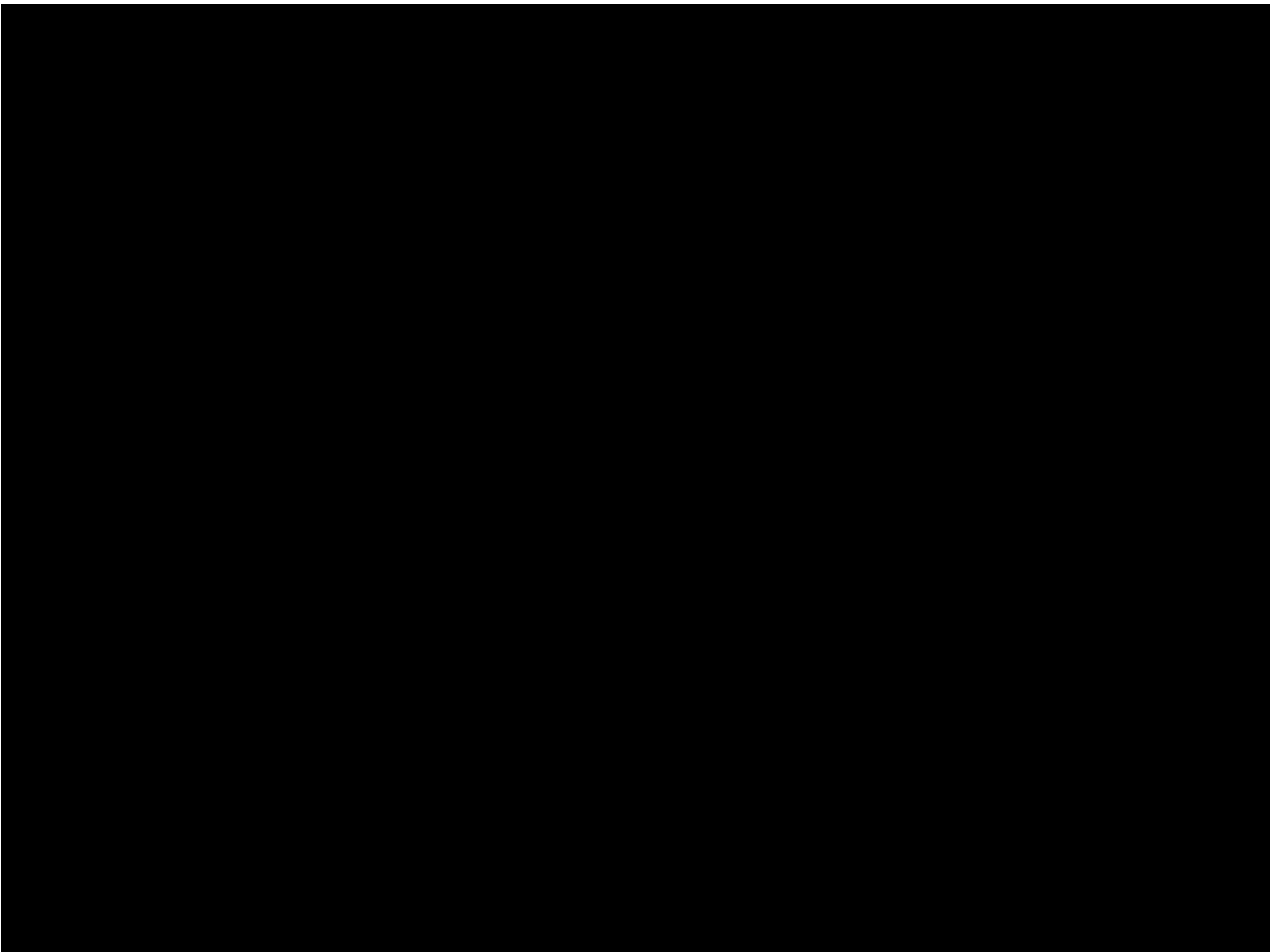


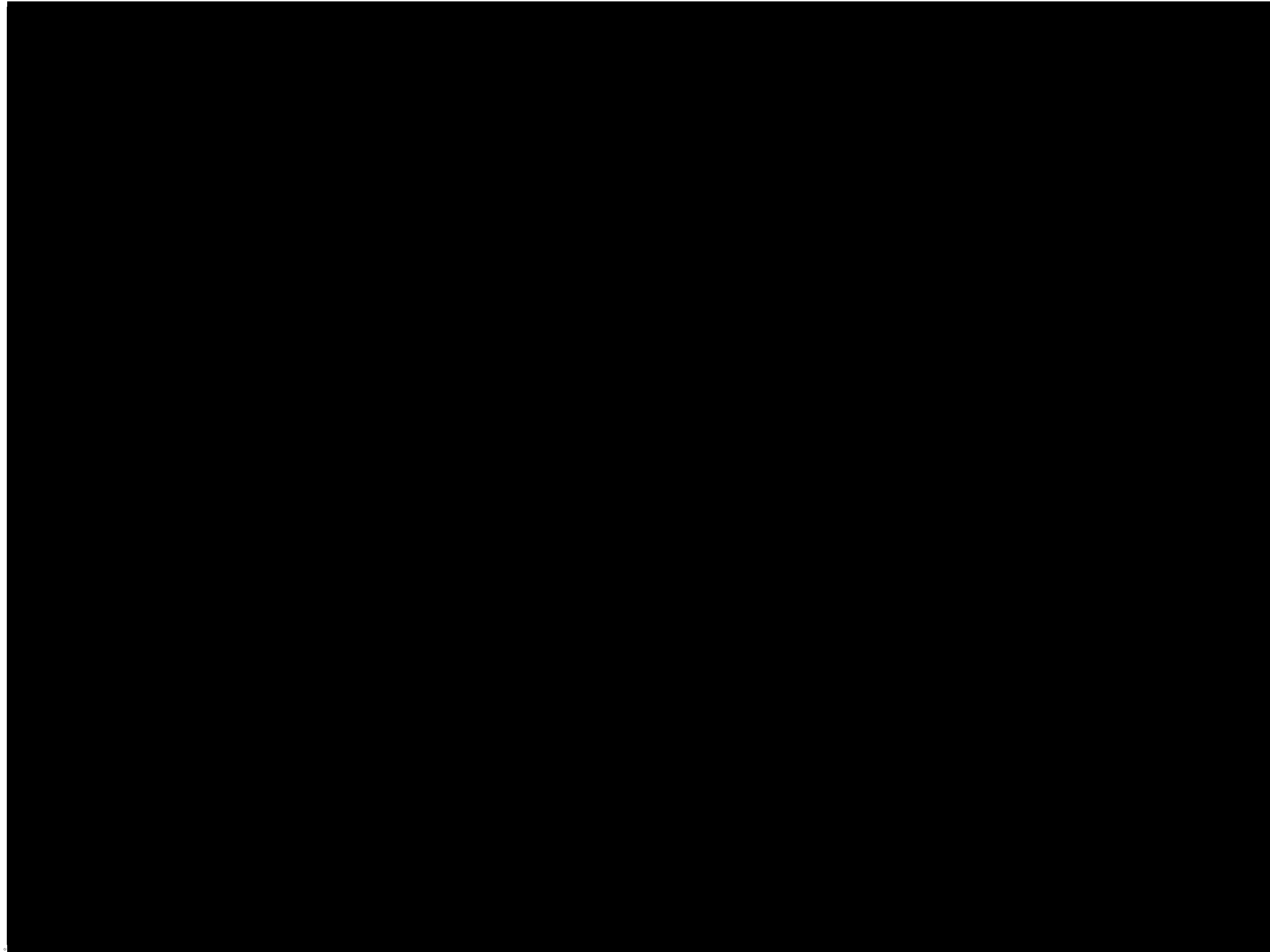


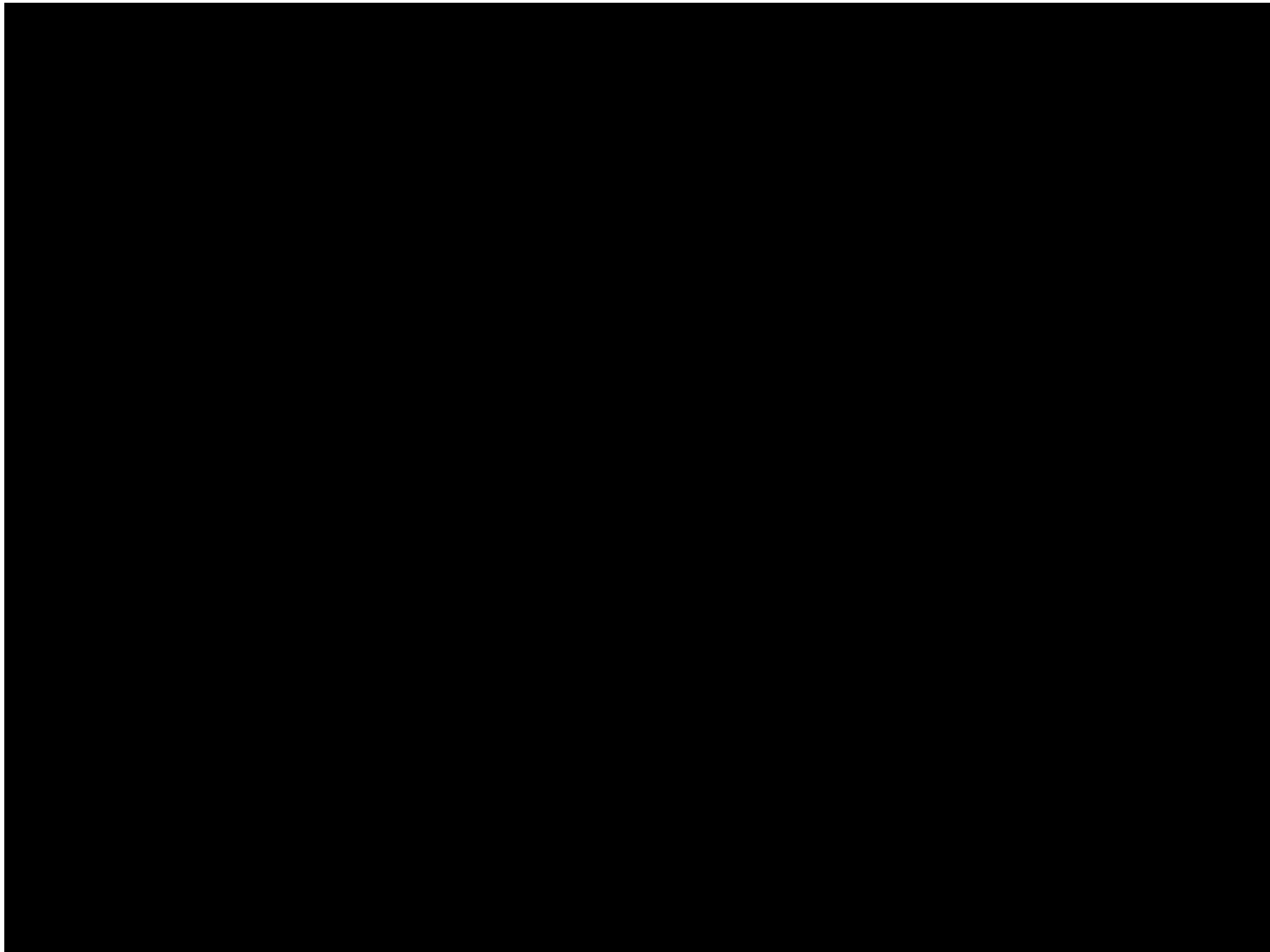


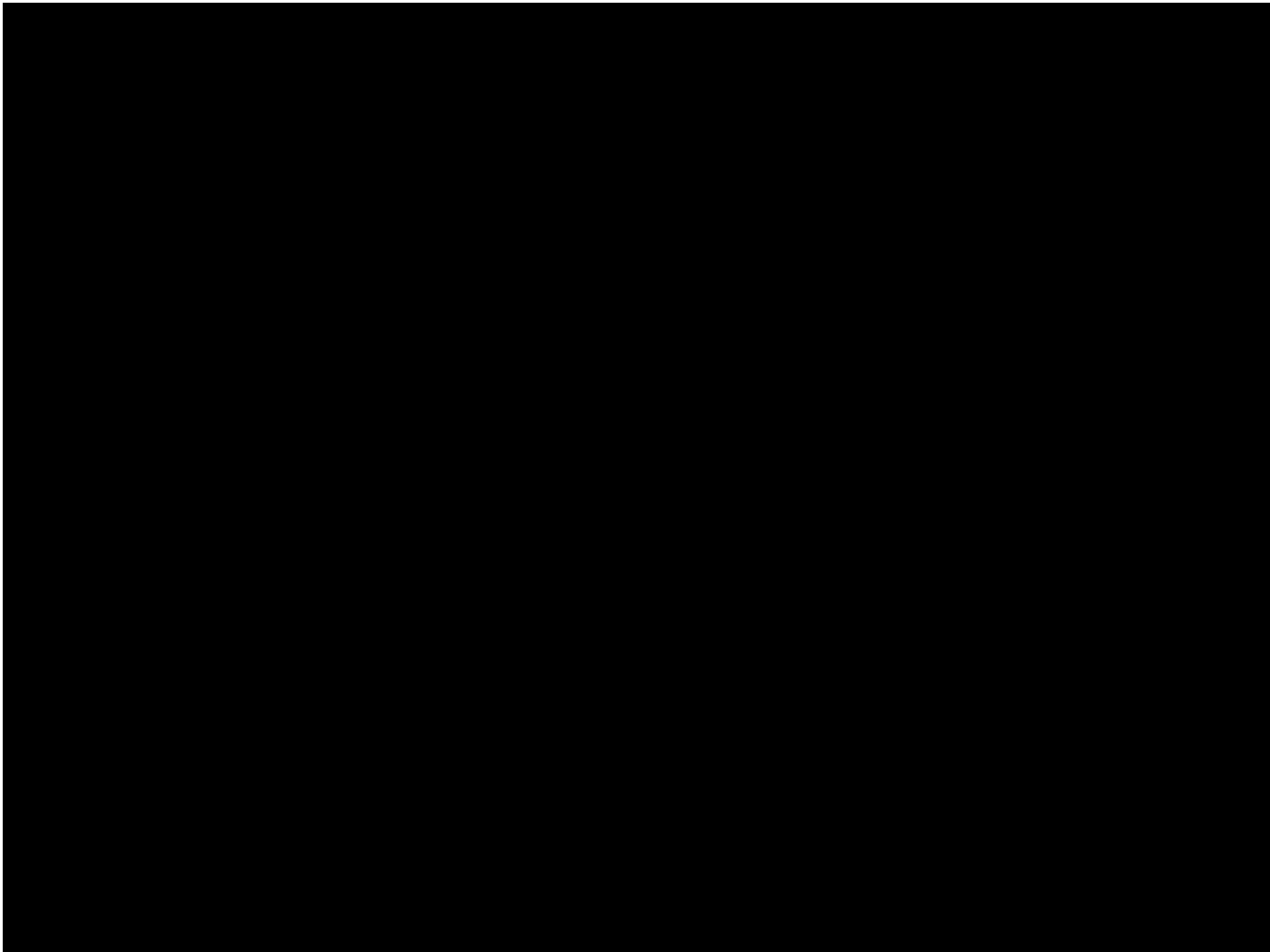


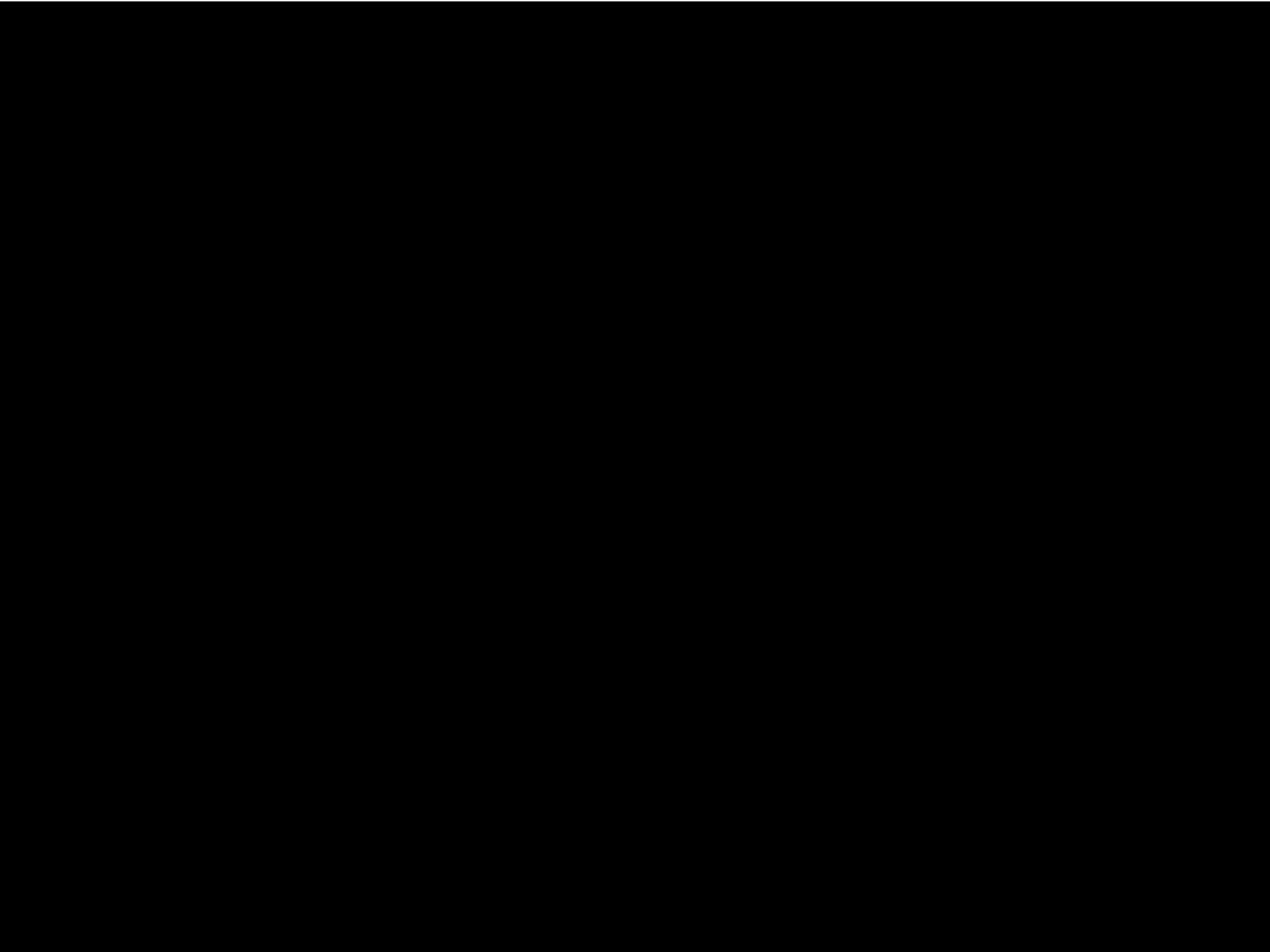


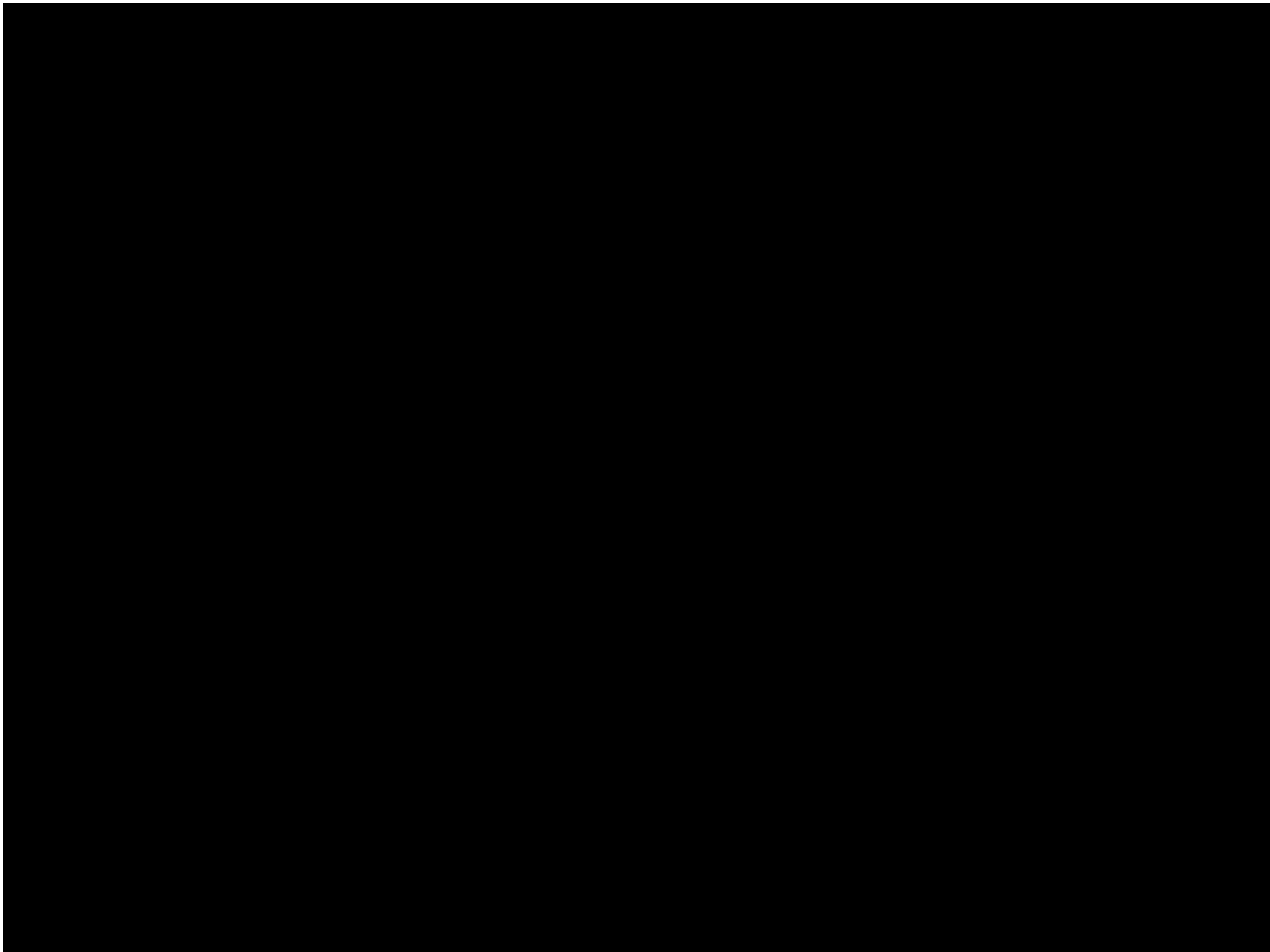


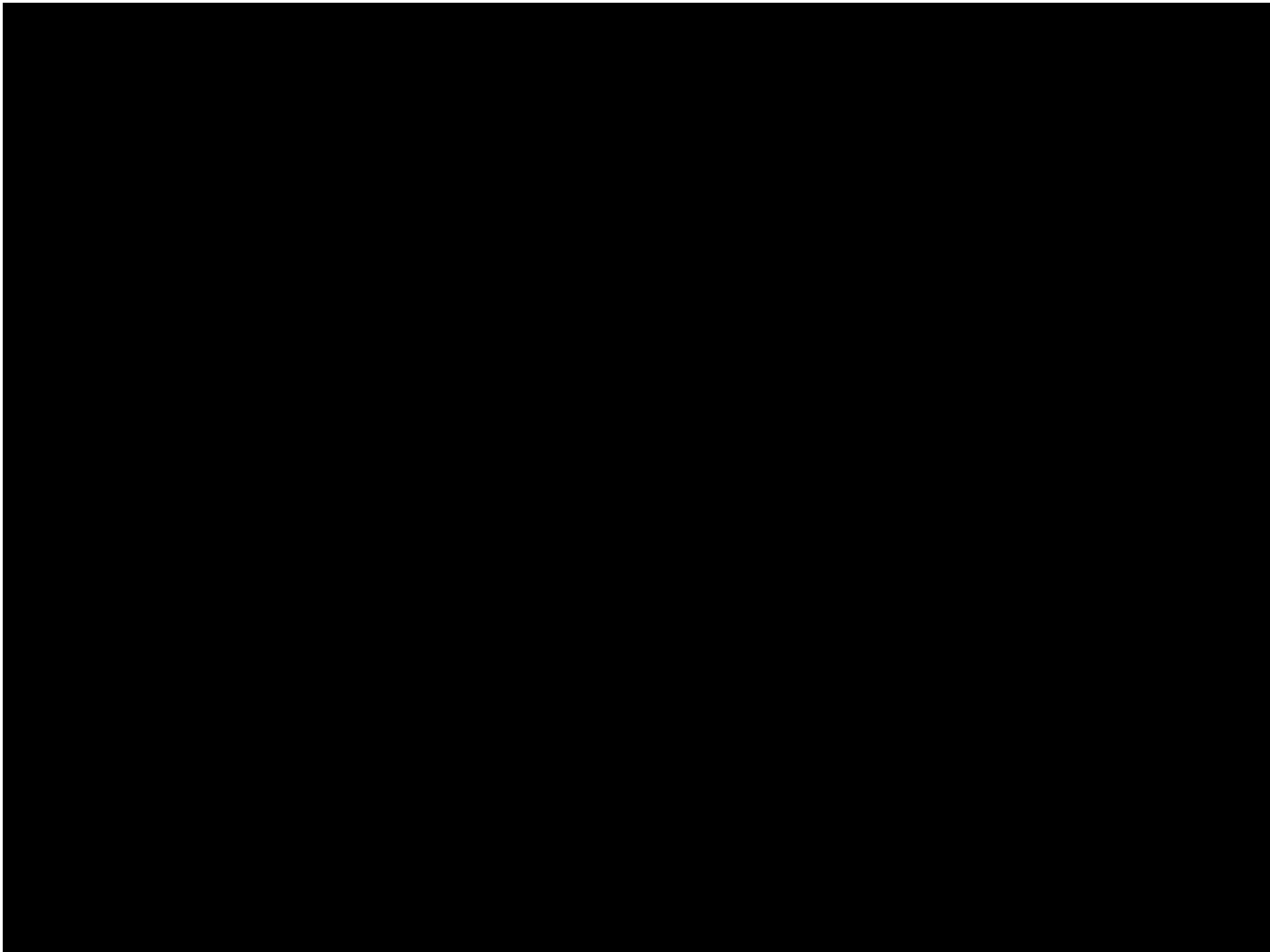


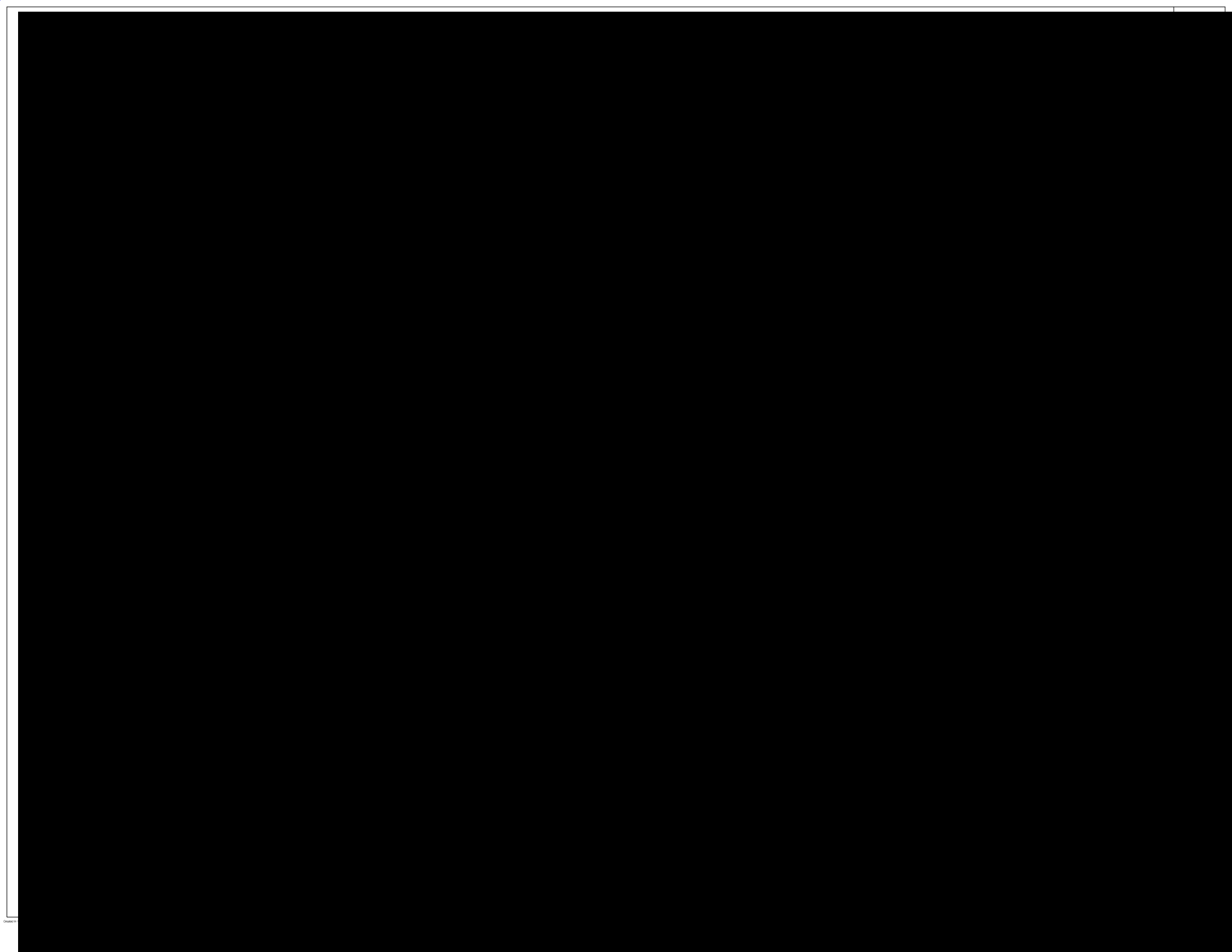














**Moss & Associates, LLC**  
 6363 NW 6th Way  
 Ft Lauderdale, FL 33309

December 04, 2025

Ronald Stein  
 City of Fort Lauderdale  
 101 NE 3rd Ave, Suite 2100  
 Ft. Lauderdale, FL 33301

RE: Potential Change Item (PCI) 0358 Notification  
 Fort Lauderdale Police Headquarters - B372302

Dear Ronald Stein,

This letter is to provide official notification of a potential change item (PCI) as follows:

PCI Number: 0358  
 Date: December 04, 2025  
 Description: Pass Thru Drawer at Evidence Lobby  
 Days Requested:  
 Reason: Owner Directive - External  
 Scope Description: 24x24 pass thru drawer, non-ballistic rated, between evidence lobby and viewing room.

This PCI is comprised of the following items:

Non-ballistic rated pass thru drawer	\$ 4,604.00
01 Subcontract Default Insurance 1.25%	\$ 57.55
02 Moss Insurance 1.75%	\$ 80.57
03 Bond 1%	\$ 46.04
04 Fee 4%	\$ 184.16

<b>Grand Total</b>	<b>\$4,972.32</b>
--------------------	-------------------

Per the terms and conditions of our contract, we have attached the appropriate back up documentation to substantiate the above referenced costs. This request only includes the items specifically identified in this change proposal. All other costs associated with this project shall be submitted under a separate change order cover.

We respectfully reserve our rights to request additional time should it become evident that this work will impact the overall completion of the project. The costs associated with this PCI will remain valid for fourteen (14) calendar days after submission.

Please indicate your formal approval for this additional work and cost by signing in the space provided below. Moss & Associates will then incorporate this change into the next Owner Change Order (OCO).

If you should have any questions, please contact the undersigned at 954-326-2727 as soon as possible.

<p>Sincerely,  <b>Moss &amp; Associates, LLC</b></p> <p>_____ Date: _____</p> <p>Matthew Kane          Project Manager</p>	<p>Reviewed / Approved by:  <b>City of Fort Lauderdale</b></p> <p><b>Approved:</b> _____ <b>Date:</b> _____          (Owner)</p>
--	--



## Lotspeich Co. of Florida, Inc.

<p><b>Broward Office:</b>          6351 N.W. 28th Way, Suite A          Ft. Lauderdale, FL 33309          Phone: (954) 978-2388          Fax: (954) 978-2387</p>	<p><b>Palm Beach Office:</b>          7435 Central Industrial Drive, Suite A          Riviera Beach, FL 33404          Phone: (954) 848-3040          Fax: (954) 848-9020</p>
--	---

website: www.lcfinc.com

### Change Request

**To:** Moss & Assoc.

**Number:** 121  
**Date:** 10/22/25  
**Job:** 06-23-6874 FTL Police Headquarters  
**Phone:**

**Description:** DW - Added Pass Thru at Property Evidence

We are pleased to offer the following specifications and pricing to make the following changes:  
 - Non Fire Rated Pass Through

Description	Price
FTL DW Extra Work	\$922.00
FTL DW Material	\$3,682.00
	Subtotal: <u>\$4,604.00</u>
	<b>Total: <u>\$4,604.00</u></b>

If you have any questions, please contact me at .

Submitted by: Connor Nitterauer  
 Lotspeich Co Of Florida, Inc

Approved by: \_\_\_\_\_  
 Date: \_\_\_\_\_

The aforementioned changes to work activity will result in: - additional working days added to the project completion date. Approval of this change order is required by . Approval of this change order after the listed date may result in additional costs and added time. Please note any exclusions or qualifications listed above. In addition, we reserve the right to quote on all costs that may be unforeseen at this time.

### Conditions Tab

#### Added Pass Thru to Property Evidence

Bid No.304

No	Name	Type	Height	Area	Quantity	Unit Price	Total
1	Non-Rated Pass Thru	Openings	0"		1 EA	4,604	<b>4,604</b>
2	Bullet Resistant Pass Thru	(unassigned)	0"		0 EA	0	<b>0</b>
						<b>Quick Sum (2 conditions) = 4,604</b>	





**Moss & Associates, LLC**  
 6363 NW 6th Way  
 Ft Lauderdale, FL 33309

December 04, 2025

Ronald Stein  
 City of Fort Lauderdale  
 101 NE 3rd Ave, Suite 2100  
 Ft. Lauderdale, FL 33301

RE: Potential Change Item (PCI) 0359 Notification  
 Fort Lauderdale Police Headquarters - B372302

Dear Ronald Stein,

This letter is to provide official notification of a potential change item (PCI) as follows:

PCI Number: 0359  
 Date: December 04, 2025  
 Description: Flooring Changes 1607 and 1703  
 Days Requested:  
 Reason: Owner Directive - External  
 Scope Description: Install carpet (CPT 1) at 1703 and LVT (Sterling Grey) at 1607 using attic stock material.  
 Includes rubber base RB01.

This PCI is comprised of the following items:

Flooring Changes 1607 and 1703	\$ 1,332.32
01 Subcontract Default Insurance 1.25%	\$ 16.65
02 Moss Insurance 1.75%	\$ 23.32
03 Bond 1%	\$ 13.32
04 Fee 4%	\$ 53.29

<b>Grand Total</b>	<b>\$1,438.90</b>
--------------------	-------------------

Per the terms and conditions of our contract, we have attached the appropriate back up documentation to substantiate the above referenced costs. This request only includes the items specifically identified in this change proposal. All other costs associated with this project shall be submitted under a separate change order cover.

Please indicate your formal approval for this additional work and cost by signing in the space provided below. Moss & Associates will then incorporate this change into the next Owner Change Order (OCO).

If you should have any questions, please contact the undersigned at 954-326-2727 as soon as possible.

<p>Sincerely,  <b>Moss &amp; Associates, LLC</b></p> <p>_____ Date: _____</p> <p>Matthew Kane          Project Manager</p>	<p>Reviewed / Approved by:  <b>City of Fort Lauderdale</b></p> <p><b>Approved:</b> _____ <b>Date:</b> _____</p> <p style="text-align: center;">(Owner)</p>
--	--



# Change Order Request of Project 24630

3350 Burris Road, Fort Lauderdale, FL 33314  
 P: 954-581-8115 • F: 954-792-0945  
 www.resource4floors.com

Quote #  
  
 Customer PO  
  
 Contract #  
  
 Date  
  
 Sales Person1  
  
 Designer

**Acct # 5698**  
 For: Fax

**Job Site:**

**HENRY'S CARPET & INTERIORS INC**  
**10392 W STATE ROAD 84 SUITE 105**  
**DAVIE, FL 33324**

**FORT LAUDERDALE POLICE**  
**HEADQUARTERS - PCO 1607 AND 1703 /**  
**ALEX, 954-270-9314**  
**100 E BROWARD BLVD**  
**FORT LAUDERDALE, FL 33301**  
**Contact: LIZ LAMBRIO 954 474-6770**

Quantity	General Information / Description	Unit Cost	Total
1		\$1,332.32	\$1,332.32
EA	CPT 1 LABOR @ 1703 - CPT AND ADHESIVE SUPPLIED BY OWNER  LVT - STERLING GREY - LABOR @1607 - LVT SUPPLIED BY OWNER  RB01 - GREY 48 TOELESS @ CPT AND COVERED @ LVT  INCLUDES FLOOR PREP (NO SELF LEVEL) - SCHONOX SL AND PRIMER  INCLUDES ALL ADHESIVES AND METAL TRANSTIONS FROM LVT/CPT TO NOTHING		

*Total*

<b>Grand Total</b>	<input type="text" value="\$1,332.32"/>
Deposit	<input type="text"/> <input type="text" value="Date"/> <input type="text" value="Ck #"/>

*THIS QUOTE IS NOT BINDING ON RESOURCE 4 FLOORS UNTIL CREDIT HAS BEEN APPROVED AND IS FURTHER SUBJECT TO THE NEGOTIATION AND EXECUTION OF A MUTUALLY ACCEPTABLE CONTRACT OR AGREEMENT, IF SO REQUIRED BY THE BUYER. A PROPERLY EXECUTED COPY OF THIS QUOTE SHALL BECOME A PART OF ANY AGREEMENT OR PURCHASE ORDER THAT YOU ISSUE TO THIS QUOTE.*

*ALL CUSTOM ORDERS WILL REQUIRE A 50% DEPOSIT BEFORE ORDER IS PLACED WITH SUPPLIER AND THE BALANCE OF THE CUSTOM MATERIAL ORDER WILL BE DUE BEFORE THE ORDER IS RELEASED FOR SHIPPING.*

*THE RECEIVING AND/OR STORAGE OF MATERIALS SHALL BE THE RESPONSIBILITY OF RESOURCE BUT THE BUYER SHALL BE RESPONSIBLE FOR PAYMENT OF THE MATERIALS ONCE RECEIVED AT RESOURCE. INVOICES FOR PARTIAL BILLING, WHERE WORK SPANS MORE THAN ONE MONTH, SHALL BE ALLOWED BY BUYER.*

*YOU SHALL PAY REASONABLE ATTORNEY'S FEES IN THE EVENT WE SHALL ENGAGE AN ATTORNEY TO ENFORCE COLLECTION OR TO PRESERVE AND PROTECT OUR RIGHTS UNDER THIS AGREEMENT OR ANY CONTRACT/AGREEMENT RESULTING FROM THIS QUOTE.*

**THIS QUOTE IS VALID FOR FIFTEEN (15) DAYS AND IS SUBJECT TO MANUFACTURER AVAILABILITY AND PRODUCTION SCHEDULES.**

*YOUR SIGNATURE BELOW INDICATES ACCEPTANCE, AGREEMENT AND ACKNOWLEDGMENT TO THE FOREGOING QUOTE UNDER ALL TERMS AND CONDITIONS SET FORTH THEREIN. YOU ARE NOW AUTHORIZING US TO PROCURE THE MATERIAL SPECIFIED ABOVE AND TO PERFORM THE WORK. ALL RETURNS OR CANCELLATIONS ARE SUBJECT TO A 20% RESTOCKING FEE.*

Continuation For: HENRY'S CARPET & INTERIORS INC, Quote # 80347

Quantity	General Information / Description	Unit Cost	Total
----------	-----------------------------------	-----------	-------

Buyer \_\_\_\_\_ Date \_\_\_\_\_  
\_\_\_\_\_

Seller \_\_\_\_\_ Date \_\_\_\_\_



**Moss & Associates, LLC**  
 6363 NW 6th Way  
 Ft Lauderdale, FL 33309

May 21, 2026

Ronald Stein  
 City of Fort Lauderdale  
 101 NE 3rd Ave, Suite 2100  
 Ft. Lauderdale, FL 33301

RE: Potential Change Item (PCI) 0365 Notification  
 Fort Lauderdale Police Headquarters - B372302

Dear Ronald Stein,

This letter is to provide official notification of a potential change item (PCI) as follows:

PCI Number: 0365  
 Date: February 01, 2026  
 Description: Pass Thru Windows at Logistics and Bag & Tag  
 Days Requested:  
 Reason: PD Request

Scope Description: : PGC to remove (2) B12 units at "Logistics" and the B7/B9 units at the "Bag and Tag" area. These units will be replaced with single hung windows. Add to contract price, includes all materials, freight for new (4) Single Hung Windows, labor, equipment, taxes. –Payment Terms for this CO – 50% Prior to fabrication and 50% balance due prior to shipping. Breakdown: - Total Security Solutions B12 (2) and B7/B9 (2) units – Furnish UL752 tested and rated level 1 – 1/1/4" uncoated acrylic glazing fabricated into aluminum vertical tube frames finished to match the original white paint finish provided on the other TSS units. Units will be 2'-6" x 5'-2" and include upper fixed panel, lower operable panel, plunger lock, and trim handle. (3) weeks for shop drawings after deposit, (8) weeks for fabrication. This work cannot be completed prior to the current Substantial Completion Date of August 5<sup>th</sup>, 2026 and cannot proceed unless separate PCI 339 is also approved, which includes a revised Substantial Completion date of September 28<sup>th</sup>, 2026.

This PCI is comprised of the following items:

Pass Thru Windows at Logistics and Bag & Tag	\$ 38,010.42
01 Subcontract Default Insurance 1.25%	\$ 475.13
02 Moss Insurance 1.75%	\$ 665.18
03 Bond 1%	\$ 380.10
04 Fee 4%	\$ 1,520.42
<b>Grand Total</b>	<b>\$41,051.25</b>

Per the terms and conditions of our contract, we have attached the appropriate back up documentation to substantiate the above referenced costs. This request only includes the items specifically identified in this change proposal. All other costs associated with this project shall be submitted under a separate change order cover.

Please indicate your formal approval for this additional work and cost by signing in the space provided below. Moss & Associates will then incorporate this change into the next Owner Change Order (OCO).

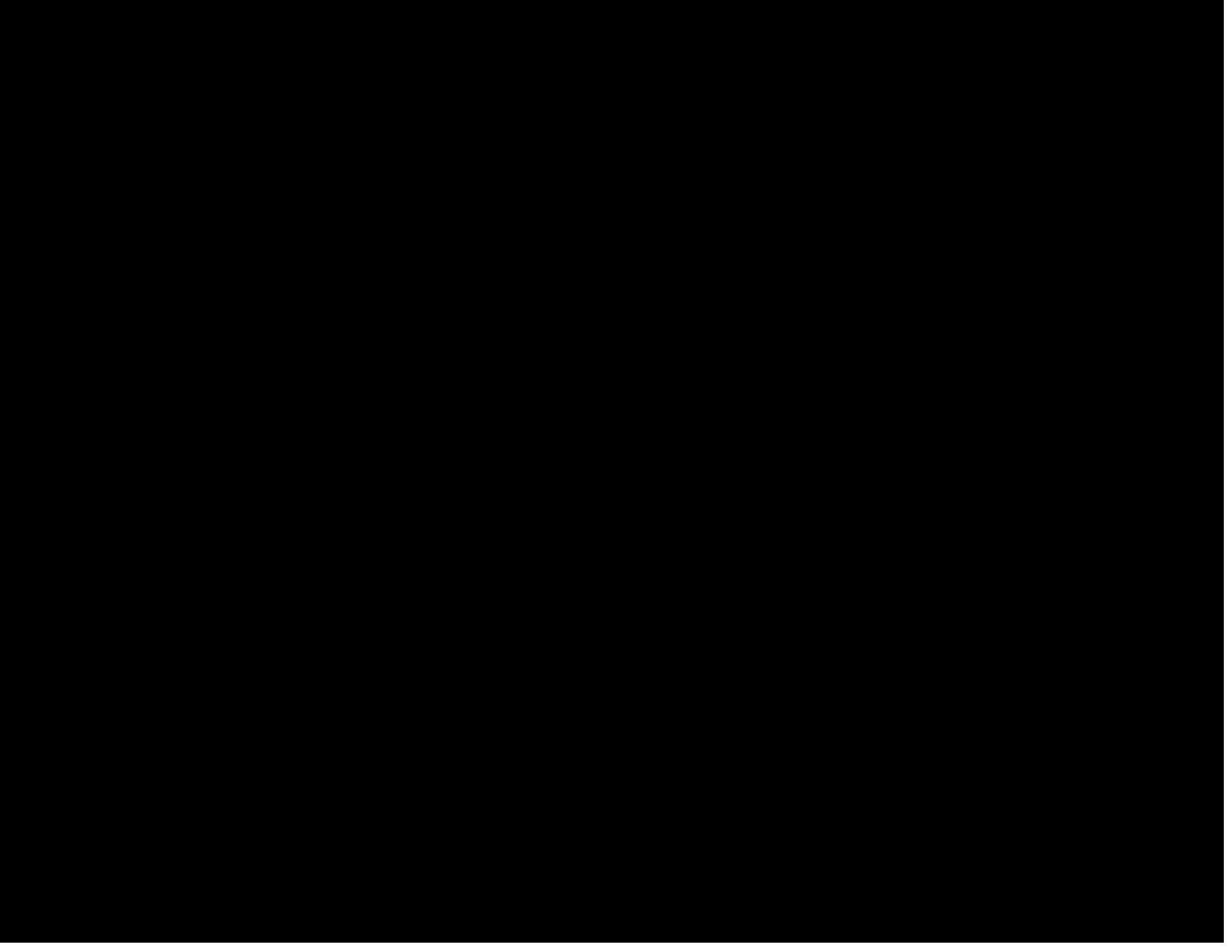
If you should have any questions, please contact the undersigned at 954-326-2727 as soon as possible.

Sincerely, <b>Moss &amp; Associates, LLC</b>  _____ Date: _____	Reviewed / Approved by: <b>City of Fort Lauderdale</b>  <b>Approved:</b> _____ <b>Date:</b> _____
--	--

Matthew Kane Project Manager	<b>(Owner)</b>
---------------------------------	----------------













# Project Proposal

Perspective Glass Company

**Proposal Number:** 20260210-205439413

**Date:** 02/10/2026

**Expires:** 60 days

Hello! I'm TESS, an AI customer agent. How can I help?

# PROJECT PROPOSAL: Ft Lauderdale Police HQ Phase 2

**Customer:** Perspective Glass Company

**Street:** 750 SW 14th Ave

**City:** Pompano Beach

**State:**

**Zip:** 33069

**Country:** US

**Ship to Company:** Perspective Glass Company

**Ship to Street:** 750 SW 14th Ave

**Ship to City:** Pompano Beach

**Ship to State:**

**Ship to Zip:** 33069

**Country:** US

## OUR PROVEN PROCESS



## OUR GUIDING PRINCIPLES

**Customer Experience** – We deliver an outstanding customer experience on every project.

**Customization** – We solve security problems and provide innovative, customized solutions.

**Speed** – We deliver bulletproof barrier systems in as little as four weeks using state-of-the-art equipment and highly-trained craftsmen.

### Bob George

Sales Representative

**P:** +1 (517) 225-1648, Ext. 212

**E:** bgeorge@tssbulletproof.com



# SCOPE OF WORK

## Window B12

Furnish UL 752 Tested & Rated Level 1: 1-1/4" uncoated acrylic glazing fabricated into aluminum vertical tube frames. All frames to be white Fluoropon paint finish. Frames are 2-1/2" x 4" tubes.

Unit Size: (2) @ 2' 6" x 5' 2" - each window includes fixed panel, operable panel, plunger lock and trim handle.

## Window B7-B9

Furnish UL 752 Tested & Rated Level 1: 1-1/4" uncoated acrylic glazing fabricated into aluminum vertical tube frames. All frames to be white Fluoropon paint finish. Frames are 2" x 8".

Unit Size: (1) @ 2' 6" x 5' 2" includes operable panel, fixed panel, slider track, trim valance, rollers, trim handle, guide blocks and plunger lock.

-----

Gaskets, fasteners, submittal drawings, product samples, test reports, product data sheets, crate and freight included.



## PROPOSAL SUMMARY

Acknowledgment of acceptance on Customer Acceptance Form means that prices, specification and conditions listed are satisfactory and hereby accepted. Options and alternatives accepted or declined will be added or removed from scope as indicated. Payment terms are fixed as provided in the quote. In the event of conflicts or discrepancies among the contract documents, interpretations will give priority to the Total Security Solutions Approval Drawings over the proposal, or any other document included with the agreement. This quote shall remain in effect for 60 days from date created. Customer is responsible for payment of state taxes.

**Subtotal:** \$21,112

**Tax:** N/A (To be calculated if applicable)

**Total Due:** \$21,112

**Payment Terms:** 50% Down/Bal. Due Prior to Ship

## QUALIFICATIONS AND EXCLUSIONS

- Structural calculations not included.
- Testing for ballistics only. A fully tested assembly unit is not rated for air or water leakage, wind debris, forced entry, fire suppression and/or thermally broken characteristics.
- Standard anodized selections limited to clear satin and dark bronze. Other options may be requested at an extra charge.
- Proposal does not include installation unless noted. Customer responsible for their own material take-offs.
- Warranty is from 1-year of ship date or installation (if noted). For all orders where TSS furnishes material only, warranty covers cost of replacement material only.
- 30% restocking fee for TSS approved returns. No returns on custom made items (i.e. doors, windows and/or systems).
- Total Security Solutions will not pay for liquidated damages for failure to meet customer's delivery or construction schedules.
- In the event of conflicts or discrepancies among specifications and plans, Total Security Solutions' proposal document serves as the defining document.
- Paint, anodized & veneers finishes not included in the above scope are subject to price review and/or change order.



# CUSTOMER ACCEPTANCE FORM

Signature of purchaser below represents Purchaser personally (a) has read, understands, and agrees with the terms herein, (b) is holding him or herself out to be authorized to bind his or her company or organization to the terms herein, (c) and that his or her company or organization is of sound financial standing so has to accommodate specifically the payment terms herein expressed.

**Signature:** \_\_\_\_\_

**Printed Name:** \_\_\_\_\_

**Title:** \_\_\_\_\_

**Company:** \_\_\_\_\_

**Date:** \_\_\_\_\_

**Material Require-By Date:** Month: \_\_\_\_\_ Day: \_\_\_\_\_ Year: \_\_\_\_\_ (ASAP & TBD are not acceptable. If a date is not provided, one will be assigned at TSS's earliest convenience based on standard lead times.)

**Contact Phone:** \_\_\_\_\_

**Contact Email:** \_\_\_\_\_

**Purchase Order Number:** \_\_\_\_\_

**Total:** \$21,112 (Taxes not included unless requested)

**Tax Exempt:** Yes / No (if yes, attach copy of Tax Exempt Certificate)

**Payment Terms:** 50% Down/Bal. Due Prior to Ship

**AP Name:** \_\_\_\_\_

**AP Phone:** \_\_\_\_\_

**AP Email:** \_\_\_\_\_

**Bill to Name:** Perspective Glass Company

**Bill to Address:** 750 SW 14th Ave

**Bill to City:** Pompano Beach

**Bill to State:**

**Bill to Zip:** 33069

**Bill to Country:** US



# SALES TERMS AND CONDITIONS

Terms contrary or inconsistent with those stated herein which may appear on a purchaser's purchase order will not be binding. Typographical and clerical errors are subject to correction. All orders are subject to final acceptance by the seller.

1. **PRICES:** Market fluctuations and price discrepancies make it necessary for us to reserve the right to adjust prices without notice. All prices are in U.S. Dollars and must be paid in U.S. Dollars.
2. **ORDERS:** Orders, Contracts are considered FINAL upon receipt of a signed proposal, or full payment.
3. **CANCELLATIONS:** Any Order canceled after receipt of a deposit and no work has been performed will be subject to a \$250.00 administrative fee. For all other Orders canceled, the customer will be responsible for the work performed up to the date of cancellation including all special-order material.
4. **PAYMENT:** Net 30 Days for established Credit Accounts from the date of invoice. For first-time customers or where the purchaser has not established adequate credit, shipments will be made on a prepaid basis only. Advance deposits may be required on special orders or unusually large purchases. TSS reserves the right to withhold deliveries on delinquent accounts and to curtail further purchases without prior notice. If Total Security Solutions, Inc. proceeds with collection of amounts past due by Customer by law or through an attorney or under the advice thereof, the undersigned agrees to pay all of Total Security Solutions' costs of collection.
5. **CREDIT CARDS:** We accept Visa, MasterCard, Discover, and American Express. A convenience fee of 3.99% is applied to credit card payments and is due at the time of payment.
6. **CHECKS:** Projects paid by check must clear the bank prior to shipment. Returned checks will be assessed a service charge of \$35.00 and payment must be made via wire transfer or cashier's check within 7 days or be placed in collection.
7. **QUOTATIONS:** All quotes are valid for 60 days from the date of quotation unless otherwise stated. TSS reserves the right to correct any typographical errors in pricing, descriptions, and terms. For International Quotes, prices do not include Duties, Customs, Broker, or Banking Fees.
8. **INTERNATIONAL ORDERS:** TSS will gladly accept any order outside of the U.S.A. and Canada. The only accepted form of payment for an international order is Wire Transfer. Please place your Order, and we will email you the Order Amount Total including all Fees and Wire Transfer information. Your order will be shipped as soon as the funds are received.
9. **TAXES:** Unless otherwise noted, taxes are an additional cost. If you are tax exempt please submit a tax exempt certificate to TSS to ensure your account is setup as such. All applicable taxes will be charged for points of delivery if a tax exemption form is not on file. No refunds will be issued should sales tax be assessed and collected due to not having a form on file. If taxes were not collected and tax liability is later determined by a governmental taxing agency, the purchaser agrees to reimburse all taxes paid plus applicable penalties and interest.
10. **SHIPPING:** All orders are subject to Freight Charges. All orders are FOB Shipping Point except as agreed in writing. TSS does our best to get you the best Freight Rate available and ship to the closest location to the customer. Freight charges will be prepaid or added to invoices for open accounts. Separate freight charges may apply if your order contains items shipping from multiple locations. Additional charges may be assessed for other special charges not communicated prior to shipping (i.e. lift-gate, 24hr notice, re-consignment fees, etc.) TSS retains a security interest in each shipment of product until that shipment is paid in full.
11. **SHIPPING CLAIMS:** The customer is responsible for inspecting received goods on the date of delivery. Claims for short shipment or damaged goods must be noted on the Bill of Lading at the time of delivery. If goods are damaged, pictures must be taken of all damaged material, including the crate, and sent to TSS. TSS should be contacted immediately. TSS assumes no responsibility for delays in shipping. Claims for inaccurate order filing or concealed damage must be made in writing within 5 days of material receipt.
12. **SPECIAL ORDERS:** Items that are non-stocked, custom-ordered, and/or fabricated just for you are non-cancellable and non-returnable for any reason. Items ordered in unusually large quantities are also non-cancellable and non-returnable.
13. **RETURNED GOODS:** Returns or exchanges are relative to product condition and warranty. Approval for returning any item must have a Return Merchandise Authorization number (RMA Number) prior to return. Returns must be in new and unused condition in original packaging. Discontinued, shop and weather-worn, and unboxed items are excluded and will not be eligible for credit. Returns must be shipped prepaid. Returns are subject to a restocking fee of 30% depending upon the item and reason for return. Credits for returned goods will be issued less applicable handling and restocking charges. No returns after 30 days. Important – Items shipped without an RMA number will not be considered for credit.
14. **CLEANING:** The customer is responsible to clean glazing products with the correct cleansers. It is the customer's responsibility to review and understand the cleaning directions completely prior to first unsupervised cleaning. It is the customer's responsibility to share the cleaning information with the correct channels to mitigate any damages. The customers will utilize the provided cleaning materials from TSS, and/or approved alternates from cleaning directions ONLY.
15. **MANUFACTURERS WARRANTY:** TSS commits to being an advocate for the customer on all warranty issues. Our staff will work to resolve warranty issues in a timely and satisfactory manner. Purchaser shall not be entitled to recover from TSS any consequential damages, liquidated damages to property, damages for loss of use, loss of time, loss of profits or income, or any other incidental damages.
16. **HOLD-TO DIMENSIONS:** In the event that hold-to dimensions are approved by the customer and utilized for manufacturing, TSS takes no liability on the sizing of the finished product vs the actual opening sizes. Unless fabricated sizes differ from approved drawings.

## CONFIDENTIALITY DISCLAIMER

*This document is intended only for the use of the individual or entity to which it is addressed and may contain information that is privileged, confidential, and exempt from disclosure under applicable law. If the reader of this document is not the intended recipient, or the employee or agent responsible for delivering the document to the intended recipient, you are hereby notified that any dissemination, distribution, or copying of this document is strictly prohibited. If you have received this document in error, please notify us immediately by telephone or email and return the original document to us at the address provided. Thank you.*





**Moss & Associates, LLC**  
 6363 NW 6th Way  
 Ft Lauderdale, FL 33309

March 08, 2026

Ronald Stein  
 City of Fort Lauderdale  
 101 NE 3rd Ave, Suite 2100  
 Ft. Lauderdale, FL 33301

RE: Potential Change Item (PCI) 0374 Notification  
 Fort Lauderdale Police Headquarters - B372302

Dear Ronald Stein,

This letter is to provide official notification of a potential change item (PCI) as follows:

PCI Number: 0374  
 Date: March 08, 2026  
 Description: Holding Cell Knee Wall Demolition  
 Days Requested:  
 Reason: Owner Directive - External  
 Scope Description: Demolish (4) knee walls in rooms 1805, 1806, 1815, and 1816. Includes patching and painting. Floors to be re-epoxied.

This PCI is comprised of the following items:

Resinous Flooring for Holding Cells	\$ 6,500.00
Demolish (4) holding cell knee walls	\$ 27,000.00
01 Subcontract Default Insurance 1.25%	\$ 418.75
02 Moss Insurance 1.75%	\$ 586.25
03 Bond 1%	\$ 335.00
04 Fee 4%	\$ 1,340.00
<b>Grand Total</b>	<b>\$36,180.00</b>

Per the terms and conditions of our contract, we have attached the appropriate back up documentation to substantiate the above referenced costs. This request only includes the items specifically identified in this change proposal. All other costs associated with this project shall be submitted under a separate change order cover.

We respectfully reserve our rights to request additional time should it become evident that this work will impact the overall completion of the project. The costs associated with this PCI will remain valid for fourteen (14) calendar days after submission.

Please indicate your formal approval for this additional work and cost by signing in the space provided below. Moss & Associates will then incorporate this change into the next Owner Change Order (OCO).

If you should have any questions, please contact the undersigned at 954-326-2727 as soon as possible.

<p>Sincerely,  <b>Moss &amp; Associates, LLC</b></p> <p>_____ Date: _____</p> <p>Matthew Kane          Project Manager</p>	<p>Reviewed / Approved by:  <b>City of Fort Lauderdale</b></p> <p><b>Approved:</b> _____ <b>Date:</b> _____</p> <p style="text-align: center;">(Owner)</p>
--	--

# DURA FLOOR, INC. d/b/a DURA BOND CO.

142 NW 29<sup>TH</sup> STREET, MIAMI, FL 33127 MIAMI: (305) 576-6533 EXT 102 TAMPA (786) 229-0333  
CELL: (305) 439-5543  
E-MAIL: [Ralph@DURAFLOOR.NET](mailto:Ralph@DURAFLOOR.NET)

## Request for Change Order

DATE: February 2, 2026

Bid #510202261

ATTN: Matthew Kane  
Project Manager  
Moss & Associates  
2101 N. Andrews Ave, Suite 300  
Fort Lauderdale, FL 33311

OFF: (954) 769-8055  
FAX: (954) 712-5999

E-MAIL : [mkane@moss.com](mailto:mkane@moss.com)

JOB: Fort Lauderdale Police Headquarters  
1300 W Broward Blvd  
Fort Lauderdale, FL 33312

Materials and labor to Patch Floor after walls are removed Using Hybri-flex EB in **RM 1805, RM 1806, RM 1815, RM 1816**

Approx: 20 SF

**Total Price: \$ 4,200.00**

### Alternate

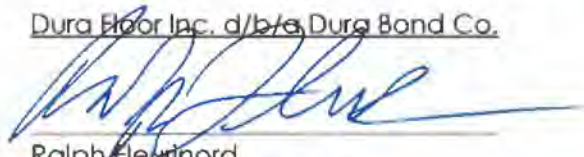
Materials and labor to Patch and Re-surface entire room after wall is removed Using Hybri-flex EB in **RM 1805, RM 1806, RM 1815, RM 1816**

APPROX: 480 SF

**Total Price: \$ 6,500.00**

**Proposal is based on one mobilization during normal hours. Any overtime or weekend scheduling would be extra if required.**

Dura Floor Inc. d/b/a Dura Bond Co.



Ralph Fleminord  
Assistant Project Manager  
Extension 112

\_\_\_\_\_  
Authorized Signature

\_\_\_\_\_  
Print Name and Title

# N&P Construction

CGC1507877  
1405 Allendale Rd  
West Palm Beach, FL 33405

# NP#26-0081

OFFICE 561-318-7575  
FAX 561-318-7577  
MOBILE 561-644-2443

## SCOPE AND PRICE SHEET

*This document is to take precedence over, and be attached to, the contract documents*

**PROJECT NAME: Fort Lauderdale HQ.**  
**1300 W Broward Blvd Ft Lauderdale, FL 33312**

**BID DATE: 02/09/2026. Revised: 02/18/2026.**

**SPECIFICATIONS: Selective Demolition.**

**ENVIRONMENTAL CONSULTING: REQUIRED. (Asbestos survey)**

**DRAWINGS: N/A.**

**SITE VISIT: N/A.**

**SCOPE: Demolish and remove the following items.**

**Selective Demolition: Option I**

1. Saw cut, separate, demolish and remove wing walls in 4 cells.
2. Patch, tooth and repair cmu block.
3. Haul and legally dispose all demo debris.

**BASE BID:** Total lump sum for demolition.....\$49,000.00

**Selective Demolition: Option II**

1. Saw cut, separate, demolish and remove 4 wing walls.
2. Haul and legally dispose all demo debris.

**BASE BID:** Total lump sum for demolition.....\$27,000.00

**Selective Demolition: Option III**

1. Saw cut, separate, demolish and remove 4 wing walls.
2. Stucco patch holes.
3. Haul and legally dispose all demo debris.

**BASE BID:** Total lump sum for demolition.....\$39,000.00

## End Scope of Work

### EXCLUSIONS:

Utility Disconnects, Protection and/or Identification: Permits or Fees of any kind  
Removal, Disposal, Handling or Identification of Asbestos, Refrigerant, PCBs, Gases, Mercury, Lead, Contaminated Soil, Other Hazardous Wastes; Grease Trap Item/s  
Salvage of Items of Owners or GC; Removal of Owners Inventory i.e. F.F&E / Stock Items  
Surface Preparation: mud/mastic removal, mats, stucco/plaster removal from masonry, grinding, fastener/nail removal, tar removal, removal of spray on insulation, chipping back over pour, Protection, Patching or Repair of Remaining Surfaces, Any and All New Work  
Selective Demolition for other trades (e.g., retrofit and MPE penetrations)  
Layout of Demolition Items: Shoring, Bracing, Tie Down Measures  
Weather and/or Dust Proofing Methods (other than water)  
Weather, Dust, or Safety related Partitions, Railing or Barricades  
Vehicular and/or Pedestrian Traffic Control (except for N&P Construction's own forces)

### CLARIFICATIONS:

This bid is based on: N&P Construction's standard insurance: **utilization of N&P's own dumpster/truck for the C&D materials inclusive of their current rates-fees (no franchise rates are included)**, usage of light, medium and heavy-duty demolition equipment, and cutting torches; a single mobilization/phase during regular business days and hours, exclusive use of elevator, within the next thirty days; agreeable contract terms. **N&P Construction reserves all scrap and/or salvage rights.** GC to supply: adequate access and egress to-into around and within the structure and site for the demolition equipment, and debris removal operations (daily), temporary lighting; asbestos survey. Additional insured available at \$350/each. Payment due after the completion of this subcontractor's work. This pricing is good for 30 days.



**Moss & Associates, LLC**  
 6363 NW 6th Way  
 Ft Lauderdale, FL 33309

May 04, 2026

Ronald Stein  
 City of Fort Lauderdale  
 101 NE 3rd Ave, Suite 2100  
 Ft. Lauderdale, FL 33301

RE: Potential Change Item (PCI) 0375 Notification  
 Fort Lauderdale Police Headquarters - B372302

Dear Ronald Stein,

This letter is to provide official notification of a potential change item (PCI) as follows:

PCI Number: 0375  
 Date: March 08, 2026  
 Description: PG East Overhead Door Motor  
 Days Requested:  
 Reason: Owner Directive - External  
 Scope Description: Add motor and controller to east PG overhead door. Includes (20) remotes.

This PCI is comprised of the following items:

Motor Operator for east PG overhead door	\$ 4,995.00
COR 79R1 Power to added overhead door motor	\$ 11,469.06
01 Subcontract Default Insurance 1.25%	\$ 205.80
02 Moss Insurance 1.75%	\$ 288.12
03 Bond 1%	\$ 164.64
04 Fee 4%	\$ 658.56

<b>Grand Total</b>	<b>\$17,781.18</b>
--------------------	--------------------

Per the terms and conditions of our contract, we have attached the appropriate back up documentation to substantiate the above referenced costs. This request only includes the items specifically identified in this change proposal. All other costs associated with this project shall be submitted under a separate change order cover.

The costs associated with this PCI will remain valid for fourteen (14) calendar days after submission.

Please indicate your formal approval for this additional work and cost by signing in the space provided below. Moss & Associates will then incorporate this change into the next Owner Change Order (OCO).

If you should have any questions, please contact the undersigned at 954-326-2727 as soon as possible.

<p>Sincerely,  <b>Moss &amp; Associates, LLC</b></p> <p>_____ Date: _____</p> <p>Matthew Kane          Sr. Project Manager</p>	<p>Reviewed / Approved by:  <b>City of Fort Lauderdale</b></p> <p><b>Approved:</b> _____ <b>Date:</b> _____          (Owner)</p>
--	--

**Best Rolling Doors, Inc.**

9780 N.W. 79 Avenue  
 Hialeah Gardens, FL 33016  
 (305)-821-6607

# Quote

Customer No.: ESTIMATOR3

Quote No.: 11306

Quote To: **MOSS CONSTRUCTION**

Fort Lauderdale  
 Police Headquarters  
 FL

Ship To: **ESTIMATING DEPARTMENT**

Date	Ship Via	F.O.B.	Terms
04/30/2026		Origin	C.O.D.
Purchase Order Number		Sales Person	Required
		Vanessa Acosta	02/27/2026
Quantity			Amount
Required	Shipped	B.O.	

**FURNISH AND INSTALL**

Quantity	Item Number	Description	Unit Price	Amount
1		(1) Manaras Motor Operator OGH -1 HP - 120V - 1 Phase Includes (20) Remotes	2745.00	2745.00
20		(20) Remote Controls Includes Programming	75.00	1500.00
1		Installation Cost Includes Equipment	750.00	750.00
Any permits by others Any conduits by others Any electrical by others  Any questions please call Quote valid for 15 days Lead times 1 - 2 weeks				
			Quote subtotal	4995.00
			Quote total	4995.00

WE APPRECIATE YOUR BUSINESS !!

Thank You



**RFI#**  
**Project Name:** FLPD  
**Project Number:** 23-414  
**Page Number:** 1  
**Change Order #:** 79R1  
**Change Order Date:** 5/4/2026

**Moss**  
2101 N ANDREWS AVE  
FT LAUDERDALE, FL 33311  
Telephone: (954) 524-5678

---

### **Scope of work**

---

At the request of ownership, this change order proposal includes the labor and material associated with retrofitting an electrical motor and controller for a manual overhead rolling door located on the east entrance of the parking garage.

Electrical power will be routed from the proposed electrical panel to a safety disconnect switch for maintenance purposes, in accordance with NEC requirements, at the roll up door location. Additional conduit provisions will be provided from the safety disconnect switch to the rolling door control panel and motor. Conduit provisions will also be roughed for low voltage wiring between the rolling door control panel, motor and keypad.

Refer to the attached takeoff pages below for reference.

This change order proposal includes providing power to the OHRD from electrical panel LG1B-2, circuit breaker #13, which is currently a 20A spare breaker not in use. If power is required from a different electrical panel and/or electrical room, a revision to this proposal will be necessary.

#### **This proposal considers the following:**

- Conduit and box provisions for electrical power and low voltage controls.
- Installation and termination of a 240V, 30A fusible safety switch at the OHRD's control panel.
- Termination of home run wires at the electrical panel circuit breaker.
- Termination of power wires to safety switch and OHRD controller.
- (2) Cores through walls

#### **This proposal excludes the following items:**

- Fire alarm system supervision or advisory.
- Startup, programming, low voltage terminations, commissioning, or factory re services (by others)
- Overhead rolling door equipment/material (by others)
- Demolition, relocation, protection, or removal of existing or completed millwork.
- Relocation, protection, or removal of furniture (by others)
- Repair, patching, and/or painting of finishing of any surfaces impacted by the conduit or box required to complete this work.
- Concrete coring, drilling, cutting and/or backfilling
- Any low voltage cabling, terminations, or free wire cabling support (by low voltage sub or Best Rolling Doors.)
- Specialty or custom materials outside of this proposal to be provided (by others.)
- Ceiling or access tile removal/replacement (by others)
- Any waterproofing (by others)
- Accelerated schedule requirements.
- After hours and/or overtime hours.
- Permit fees.

**All remedial or repair work necessary due to these changes is to be performed by others. Any unforeseen conditions, code requirements, or field conflicts discovered after work begins that impact labor or material shall be addressed via additional cost and time adjustment.**

---

### **Summary**

---



RFI#  
 Project Name: FLPD  
 Project Number: 23-414  
 Page Number: 2  
 Change Order #: 79R1  
 Change Order Date: 5/4/2026

**Moss**  
 2101 N ANDREWS AVE  
 FT LAUDERDALE, FL 33311  
 Telephone: (954) 524-5678

---

**Summary (Cont'd)**

---

**MATERIAL**

General Materials		2,325.20	
Switchgear		124.97	
Material Tax	(@ 7.000 %)	171.51	
		<hr/>	
<b>Material Total</b>			<b>2,621.68</b>

**LABOR**

ELECTRICIAN	(81.64 Hrs @ \$55.00)	4,490.20	
FOREMAN	(19.54 Hrs @ \$65.00)	1,270.10	
SUPERINTENDENT	(7.97 Hrs @ \$70.00)	557.90	
PROJECT MANAGER	(2.42 Hrs @ \$85.00)	205.70	
CLEAN UP @ 4.0%	(8.00 Hrs @ \$52.00)	416.00	
ESTIMATING	(5.00 Hrs @ \$55.00)	275.00	
		<hr/>	
<b>Total Labor</b>			<b>7,214.90</b>

**EQUIPMENT**

25'-26' ELECTRIC SCISSOR LIFT NARROW		589.84	
		<hr/>	
<b>Total Equipment</b>			<b>589.84</b>

**TOTAL MATERIAL, LABOR & EQUIPMENT**

**10,426.42**

OH&P	(@ 10.000 %)		1,042.64
		<hr/>	

**Final Amount**

**\$11,469.06**



**Moss**  
 2101 N ANDREWS AVE  
 FT LAUDERDALE, FL 33311  
 Telephone: (954) 524-5678

**Project Name:** FLPD  
**Project Number:** 23-414  
**Page Number:** 3  
**Change Order #:** 79R1  
**Change Order Date:** 5/4/2026

**Itemized Breakdown**

**PG-E2-2-1B**

Description	Qty	Net Price U	Total Mat.	Labor U	Total Hrs.
1" DIAM CORE 8" THICK WALL	2	75.00 E	150.00	0.00 E	0.00
3/4" CONDUIT - EMT	440	154.78 C	681.03	4.40 C	19.36
3/4" COUPLING COMP STL - EMT	44	424.55 C	186.80	37.50 C	16.50
3/4" CONN COMP STL INSUL - EMT	20	471.66 C	94.33	15.63 C	3.13
3/4" 1-H STRAP - EMT - STEEL	7	51.58 C	3.61	6.75 C	0.47
1/2 OR 3/4" CONDUIT SNAP CLOSE CLIP W/ 1/4-20 THRD	51	52.18 C	26.61	7.13 C	3.64
1/4-20 MACHINE SCREW ANCHOR	51	29.24 C	14.91	10.00 C	5.10
1/4" THREADED ROD - PLTD	152	68.72 C	104.45	3.13 C	4.76
1/4-20 HEX NUT - PLTD STL	51	3.14 C	1.60	2.50 C	1.27
1/4" FLAT WASHER - PLTD STL	6	2.92 C	0.18	1.25 C	0.07
#10x 1 P/H SELF-TAP SCREW	7	12.00 C	0.84	3.75 C	0.26
3/16x 1 1/4 CONCRETE SCREW HEX HEAD - BLUE	7	45.53 C	3.19	8.50 C	0.59
1/4x 1 3/4 CONCRETE SCREW HEX HEAD - BLUE	6	69.08 C	4.14	10.75 C	0.65
#14 THHN BLACK	156	161.19 M	25.15	5.38 M	0.84
#10 THHN BLACK	340	393.32 M	133.73	7.06 M	2.40
#14 THHN RED	156	161.19 M	25.15	5.38 M	0.84
#14 THHN WHITE	156	161.19 M	25.15	5.38 M	0.84
#10 THHN WHITE	340	393.32 M	133.73	7.06 M	2.40
#10 THHN GREEN	340	393.32 M	133.73	7.06 M	2.40
LETTER (ROLL) MARKERS T&B	1	34.37 E	34.37	1.25 E	1.25
WIRE PULLING LUBRICANT (QUART)	1	12.79 E	12.79	2.50 E	2.50
1/8" POLYTWINE	496	11.94 M	5.92	3.75 M	1.86
30A 250V DSN SW FUSIBLE - NEMA 3R	1	523.79 E	523.79	1.50 E	1.50
DSN SWITCH STORAGE	1	0.00 E	0.00	0.00 E	0.00
DSN SWITCH RECEIVE AND UNLOAD	1	0.00 E	0.00	0.00 E	0.00
DSN SWITCH PUT INTO PLACE	1	0.00 E	0.00	0.00 E	0.00
DSN SWITCH COMMISSIONING	1	0.00 E	0.00	0.00 E	0.00
1 HP 1-PHASE 120V MOTOR TERMINATION	8	0.00 E	0.00	0.25 E	2.00
<b>Totals</b>	<b>2,843</b>		<b>2,325.20</b>		<b>74.63</b>

**PG-E5-1-11**

Description	Qty	Net Price U	Total Mat.	Labor U	Total Hrs.
WIRE TERMINATION AT CIRCUIT BREAKER	1	0.00 E	0.00	1.00 E	1.00

Phone: 305-669-1776 Fax: 305-669-1710



**Moss**  
2101 N ANDREWS AVE  
FT LAUDERDALE, FL 33311  
Telephone: (954) 524-5678

**Project Name:** FLPD  
**Project Number:** 23-414  
**Page Number:** 4  
**Change Order #:** 79R1  
**Change Order Date:** 5/4/2026

Description	Qty	Net Price U	Total Mat.	Labor U	Total Hrs.
Totals	1		0.00		1.00

---

### CLIENT ACCEPTANCE

---

<b>Name:</b>	_____
<b>Date:</b>	_____
<b>Signature:</b>	_____

I hereby accept this quotation and authorize the contractor to complete the above described work.

## Brandon Rodriguez

---

**From:** Hung, Adrian <adrian.hung@anixter.com>  
**Sent:** Tuesday, March 3, 2026 5:47 PM  
**To:** Hung, Adrian  
**Subject:** Bid SE45543659

## Quotation

**#3863 MIAMI APS**  
**ANIXTER INC.**  
**11420 NORTHWEST 122ND ST**  
**SUITE 100**  
**MEDLEY FL 33178**  
**305-805-3830 Fax 305-805-3869**

SE45543659  
17:46:37EST 03/03/26

All sales are subject to Anixter Inc.'s Terms & Conditions of Sale found at [https://www.anixter.com/en\\_us/resources/terms-of-sale.html](https://www.anixter.com/en_us/resources/terms-of-sale.html) PRODUCT SAFETY DATA SHEETS ON SAME WEB SITE.

**Sold To:48923**  
THUNDER ELECTRICAL CONTRACTORS  
INC  
7035 F SW 47TH STREET STE F  
MIAMI, FL 33155  
305-669-1776 Fax 305-669-1710

**Ship To:48923**  
THUNDER ELECTRICAL CONTRACTORS  
INC  
7035 F SW 47TH STREET STE F  
MIAMI, FL 33155  
305-669-1776 Fax 305-669-1710

Ordered By	Ship Via	Quote Date			
.		03/03/26			
Writer	Freight Terms/FOB	Expiration Date			
Adrian Hung	No	03/13/26			
Salesperson	Terms	FOB			
Adrian Hung	NET 10TH PROX 1.5% SC 25				
Special Instructions					
Quantity	Product Description	FD	Unit Price	UM	Net Amount
1ea	C-H DG321NRB 30A 240V SFTY SW		102.271	ea	102.27
3ea	FRZ TR20R 20A 250V RK5 TD FUSE		7.566	ea	22.70
Wesco may assess storage and transportation fees if you do not take or accept delivery within 90 days of product availability. Wesco may also update this quote or above pricing due to duties, freight, tariffs, supplier pricing, surcharges, or exchange rate fluctuations. BY ACCEPTING THIS QUOTE, YOU AGREE THAT THE TERMS AND CONDITIONS OF SALE PUBLISHED AT <a href="http://www.wesco.com/termsofsale">www.wesco.com/termsofsale</a> ARE EXPRESSLY					

INCORPORATED INTO AND SHALL GOVERN THIS TRANSACTION.			
Total Weight 6.1 lbs		<b>Subtotal</b>	124.97
THIS IS A QUOTATION		S&H	0.00
Prices are firm until 03/13/26, subject to change without notice after 03/13/26.		<b>Tax</b>	<b>8.75</b>
SALES TAX IS AN ESTIMATE!S&H IS AN ESTIMATE!		<b>Total</b>	<b>133.72</b>

## Brandon Rodriguez

---

**From:** Matthew Kane <mkane@moss.com>  
**Sent:** Sunday, March 1, 2026 9:53 PM  
**To:** Brandon Rodriguez; Pedro J. Hernandez  
**Cc:** James Pope; John-James Yancey; Tiago Lima  
**Subject:** FW: FLPH - Garage door opener with remotes  
**Attachments:** QUOTE 11306 MOSS FORT LAUDERDALE .pdf; Manaras Motor OGH SPECS.pdf

Brandon, could you please provide a quote for bringing power to an added motor to east PG overhead door?

Matthew Kane  
Project Manager  
**Moss**  
Cell: 321.427.3500  
[moss.com](http://moss.com)

---

**From:** Vanessa Acosta <vacosta@bestrollingdoors.com>  
**Sent:** Friday, February 27, 2026 1:40 PM  
**To:** Matthew Kane <mkane@moss.com>  
**Cc:** Tiago Lima <tlima@moss.com>; John-James Yancey <jjyancey@moss.com>; James Pope <jpope@moss.com>  
**Subject:** Re: FLPH - Garage door opener with remotes

**CAUTION: This email originated from outside of Moss**

Do not click links or open attachments unless you can confirm the sender and know the content is safe.  
Be careful of any attachments or links that ask for your password.

Good afternoon, Matthew  
Please see attached quote for the motor operator and 20 remotes being programmed.



James,

Grainger had to reorder the fuses and with expediate shipping will be available at their Miami Branch on Monday at 11 am. I will have Andres pick up the new ones and head up to the jobsite to change the wires and install the fuse.

**Vanessa Acosta**

 **BEST ROLLING DOORS, INC.**

9780 N.W. 79 Avenue  
Hialeah Gardens, FL 33016  
O 305-821-6607  
F 305-362-8687  
USA 1-866-939-2705  
[bestrollingdoors.com](http://bestrollingdoors.com)

Miami // Tampa

**From:** Matthew Kane <[mkane@moss.com](mailto:mkane@moss.com)>  
**Sent:** Wednesday, February 25, 2026 9:13 AM  
**To:** Vanessa Acosta <[vacosta@bestrollingdoors.com](mailto:vacosta@bestrollingdoors.com)>  
**Cc:** Tiago Lima <[tlima@moss.com](mailto:tlima@moss.com)>; John-James Yancey <[jjyancey@moss.com](mailto:jjyancey@moss.com)>; James Pope <[jpope@moss.com](mailto:jpope@moss.com)>  
**Subject:** FLPH - Garage door opener with remotes

Good Morning Vanessa, please let us know if its possible to retrofit the manual overhead door on the east side of the parking garage, and if so provide price including 20 remotes.

Thank you,

Matthew Kane  
Project Manager  
**Moss**  
Cell: 321.427.3500  
[moss.com](http://moss.com)

---

**From:** Ronald Stein <[RStein@fortlauderdale.gov](mailto:RStein@fortlauderdale.gov)>  
**Sent:** Wednesday, February 25, 2026 9:11 AM  
**To:** Matthew Kane <[mkane@moss.com](mailto:mkane@moss.com)>  
**Cc:** Alan Ragoonanan - PDuser <[ARagoonanan@flpd.gov](mailto:ARagoonanan@flpd.gov)>  
**Subject:** FW: Garage door opener with remotes

**CAUTION: This email originated from outside of Moss**

Do not click links or open attachments unless you can confirm the sender and know the content is safe.  
Be careful of any attachments or links that ask for your password.

Matt  
Please get me a price to install a motorized opener with a remote control (20 remotes) on the East side OHDR in the garage.  
Obviously an electric feed will be needed.  
This is needed ASAP.  
Thanks  
Ron

**Ronald Stein**  
**Sr. Project Manager**  
101 NE 3<sup>rd</sup> Ave, Suite 2100 | Fort Lauderdale FL 33301  
City of Fort Lauderdale  
C: (954) 531-2395 | E: [RStein@fortlauderdale.gov](mailto:RStein@fortlauderdale.gov)



---

**From:** Alan Ragoonanan <[ARagoonanan@flpd.gov](mailto:ARagoonanan@flpd.gov)>  
**Sent:** Wednesday, February 25, 2026 7:43 AM  
**To:** Ronald Stein <[RStein@fortlauderdale.gov](mailto:RStein@fortlauderdale.gov)>; Caroline Yeakel <[CYeakel@fortlauderdale.gov](mailto:CYeakel@fortlauderdale.gov)>; PD Maintenance <[PDMaintenance@flpd.gov](mailto:PDMaintenance@flpd.gov)>; Timothy McCarthy - PDuser <[TMcCarthy@flpd.gov](mailto:TMcCarthy@flpd.gov)>  
**Subject:** [EXTERNAL:CAUTION!]- Garage door opener with remotes

**[::CAUTION!:] This email originated from *outside* The City of Fort Lauderdale.  
Do Not Reply, click links, or open attachments from an unknown or suspicious origin. Confirm the email address is from an expected source before taking action.  
Report any suspicious emails to [spamadmin@fortlauderdale.gov](mailto:spamadmin@fortlauderdale.gov)**

---

Hi Ron,

Per our discussion yesterday, I would like to request the installation of a new garage door operator on the south side of Parking Garage Level 1.

We will also need power run to the garage door to support the new operator.

Additionally, please provide at least 20 remotes for the specialty vehicles located on the first floor of the parking garage.

Please let me know the next steps and estimated timeline for completion.

Thank you



**Alan Ragoonanan | Facilities Supervisor .**

**Support Services Bureau | Police Department**

**City of Fort Lauderdale**

1350 West Broward Blvd ,Fort Lauderdale ,33312

O: 954-828-5474 | C: 954-296-5038

E:alanra@flpd.gov

**WeAreFTL**

# Product Specification Sheet



# OPERA-GH

## JACKSHAFT OPERATOR HEAVY-DUTY INDUSTRIAL GEARHEAD

### STANDARD FEATURES

- **Motor:**

60Hz high starting torque, continuous-duty, single phase capacitor start or 3-phase motor, open drip proof with enclosed ends or drip cover, protected against overload. Also available with 50Hz 220V 1 phase and 380V 3 phase motor, consult inside sales.

- **Reduction:**

45:1 worm gear in oil bath reducer with air breather and sealed ball bearings. Output shaft is 1" with 1/4" keyway up to 1HP, 1-1/4" output shaft with 1/4" keyway above 1HP. Output shaft speed: 38 rpm.

- **Drive:**

#50 roller chain with a 50B12 sprocket for the operator drive shaft. Door sprocket selected for a door travel of 6"/s to 12"/s.

- **Brake:**

Electrically activated drum-band type solenoid brake.

- **Manual Operation:**

Hoist-a-matic® self-engaging hoist with automatic cut-off (floor level engagement device is not required to operate).<sup>(1)</sup> An electrical interlock automatically disconnects power to the motor operator when chain hoist is engaged. Hoist on right is standard, but it can be easily moved to the left in the field.

- **Electrical Enclosure:**

All electrical components are in a Nema 1 enclosure. Hinged electrical enclosure cover.

- **Limit System:**

Rotary-type oil-impregnated steel cams, commercial grade switches. Limit shaft is supported by self-lubricating bronze bushings for increased precision. Remains in time when there is a manual operation or after the motor has been removed.

- **Accu-cam® Feature:**

Precise and quick limit setting by single-hand operation.

- **Corrosion Protection:**

Reducer, control enclosure and frames protected by baked on, long lasting enamel finish. Polymer control box cover. Limit and hoist shafts protected by yellow chromate coating.

- **Mounting:**

Wall mounted, vertical front of hood mounted or horizontal top of hood mounted, on the right or the left of the door. The use of a wall mounting bracket is recommended. For indoor use only.

- **Shipping Weight:**

Approx. 122 lb - 55 kg.

- **Warranty:**

2 years.

### Hoist-a-matic®

Self-engaging chain hoist with automatic cut-off

### Accu-cam® Limit Feature

For precise and quick one-hand limit setting adjustments

### Hinged Cover with Stable Opened Position

For easy access to components and wiring



**The Opera-GH is a heavy-duty worm gear industrial operator designed for use on industrial standard, high and vertical lift sectional doors or rolling doors and grilles.**

**The operator can be wall, hood, or shelf mounted on either side of the door. It incorporates the patented Hoist-a-matic®, a self-engaging chain hoist for manual operation, which simplifies operation and installation.**

**The operator is available with the Electronic Control Board (BOARD 070) with or without the option of electrical control for MONITORED external entrapment protection devices (ANSI/CAN/UL325 compliant).**

<sup>(1)</sup> The hoist is designed for light and limited use in the event of troubleshooting only.



When you think  
Commercial Door OPERATORS,  
just think OPERA.

800-361-2260

info@manaras.com

CAM #28-05-10 manaras.com

Exhibit 3

## CONTROL OPTIONS

### • ECB Units (BOARD 070):

24Vdc relaying circuit with a 40VA class II transformer, non-volatile memory. Features available: On-board radio receiver, 1.5s delay on reverse, programmable maximum run timer, mid-stop, timer to close (suspension possible from floor level), built-in cycle-counter, independent input loop terminal, advance close system, test buttons, reverse wiring detection and door lock sensor. Operating mode selectable on site: C2, B2, D1, E2, T or TS.

### • "M" Version:



Provides the monitoring of Primary External Entrapment Protection Devices. Includes monitored photoelectric cells (PHOTO 070 standard). In this mode, Ancillary Entrapment Protection Devices (optional) may be used to supplement primary entrapment protection, such as non-monitored photoelectric cells, 2-wire non-monitored sensing edges and pneumatic sensing edges. Certifications: ANSI/CAN/UL 325, CAN-CSA C22.2 No.247.

### • "E" Version:



No monitoring function. Certifications: CAN-CSA C22.2 No.247 and compliant to UL 325 5th Ed. PRIOR to August 2010 revision.

### • Contactor Units:

4VAC control circuit, 40VA class II transformer, fuse protected on output, heavy-duty across-the-line linear reversing contactor with mechanical interlock.

### • B2/C2 Units:



C2 wiring is standard. B2 can be set very easily by moving one wire. Available options: delay on reverse, timer to close, double limits, etc. Certifications: CAN-CSA C22.2 No. 247 and compliant to UL 325 5th Ed. PRIOR to August 2010 revision.

**Note:** ANSI/CAN/UL 325 and CAN-CSA C22.2 No. 247 apply to units intended to be used in ordinary locations in accordance with the Canadian Electrical Code, Part I and the National Electrical Code, NFPA 70, respectively.

## MAIN OPTIONS

### • Control Accessories:

Angled terminal strip allows for the connection of 3-button stations (one supplied with the operator), non-monitored sensing edges/photoelectric cells/light curtains, external radio receiver, ceiling pull switches, key switches, loop detectors, LED strips, external interlocks, universal auxiliary output module. Optional Manaras Internet Control™ (MIC) available. 2A fuse protected 24VAC output is available for accessory power supply. Nema 4/12 or Nema 4X protected monitored photo cells upgrade available.

### • Environmental Modifications:

Former GH model available. Nema 4/12, Nema 4X and Nema 7/9 enclosures, consult inside sales.

### • Friction Clutch (Optional):

Easily adjustable slip clutch, ideally positioned on output shaft. Recommended for sectional doors.

### • Mechanical Accessories:

Wall or hood mounting bracket, chain spreader, hand crank etc. Consult inside sales.

### • Mechanical Modifications:

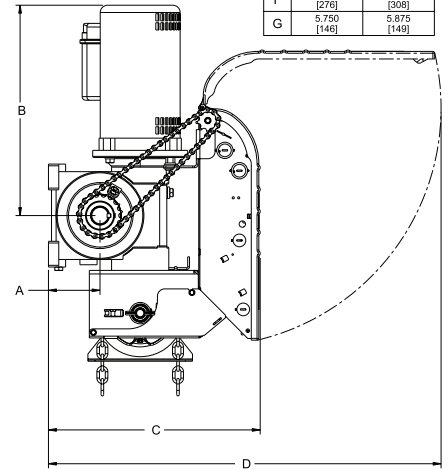
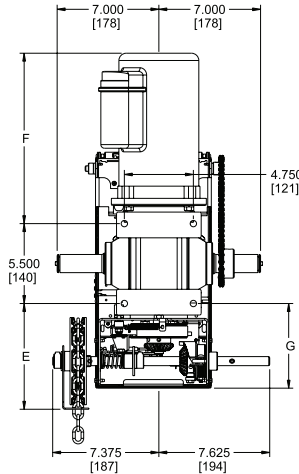
Left hand chain hoist, #60 roller chain, sprocket on final drive, limit shaft speed-up, etc. Consult inside sales.

### • Rapido RGH:

Heavy-duty industrial worm gear operator with high-speed, high-cycling daily frequency requirements. Consult inside sales.

## DIMENSIONS

**Clearance:** Side room required 15" (380 mm)  
With friction clutch add: 1.5" (38 mm)



	UP TO 1 HP	1.5 & 2 HP
A	3.000 [76]	3.500 [89]
B	13.625 MAX. [346]	14.875 MAX. [378]
C	14.000 [356]	14.625 [371]
D	26.500 [673]	27.125 [689]
E	7.250 [184]	7.375 [187]
F	10.875 MAX. [278]	12.125 MAX. [308]
G	5.750 [146]	5.875 [149]

## MOTOR SELECTION

Maximum Size of Door in Square Feet

Horse Power	Rolling Doors					Sectional Doors				
	Insulated Steel	16 ga. Steel	Steel Grilles 20 ga. Steel	Alu. Door 22 ga. Steel	Alu. Grilles 24 ga. Steel	Steel 18 ga. ins.	Steel 18 ga. 20 ga. ins.	Wood Steel 20 ga. 22 & 24 ga. ins.	Aluminum 22 & 24 ga.	Fiberglass
1/2	157	236	260	319	358	196	245	314	343	392
3/4	206	294	358	451	515	270	319	441	490	549
1	255	358	446	574	613	294	392	490	564	613
1-1/2	353	486	633	-	-	373	466	549	613	-
2	451	613	-	-	-	-	-	-	-	-

General Guideline

## OPERATOR RANGE

Current Consumption (Amp.)

Horse Power	120V 1 Ph	240V 1 Ph	208/240V 3 Ph	480V 3 Ph	600V 3 Ph
1/2	8.6	4.1	2.2	1.1	-
3/4	10.4	5.2	2.8	1.4	1.1
1	13.4	6.7	3.4	1.7	1.4
1-1/2	18.6	9.3	4.8	2.4	1.9
2	-	-	6.2	3.1	2.5

General Guideline



Manaras-Opera reserves the right to make specification or design changes without prior notice.

©2022 9141-0720 Québec Inc. All rights reserved. Reg. T.M. of 9141-0720 Québec Inc. UL logo is a Reg. T.M. of UL LLC. I CSA logo is a Reg. T.M. of CSA Group.

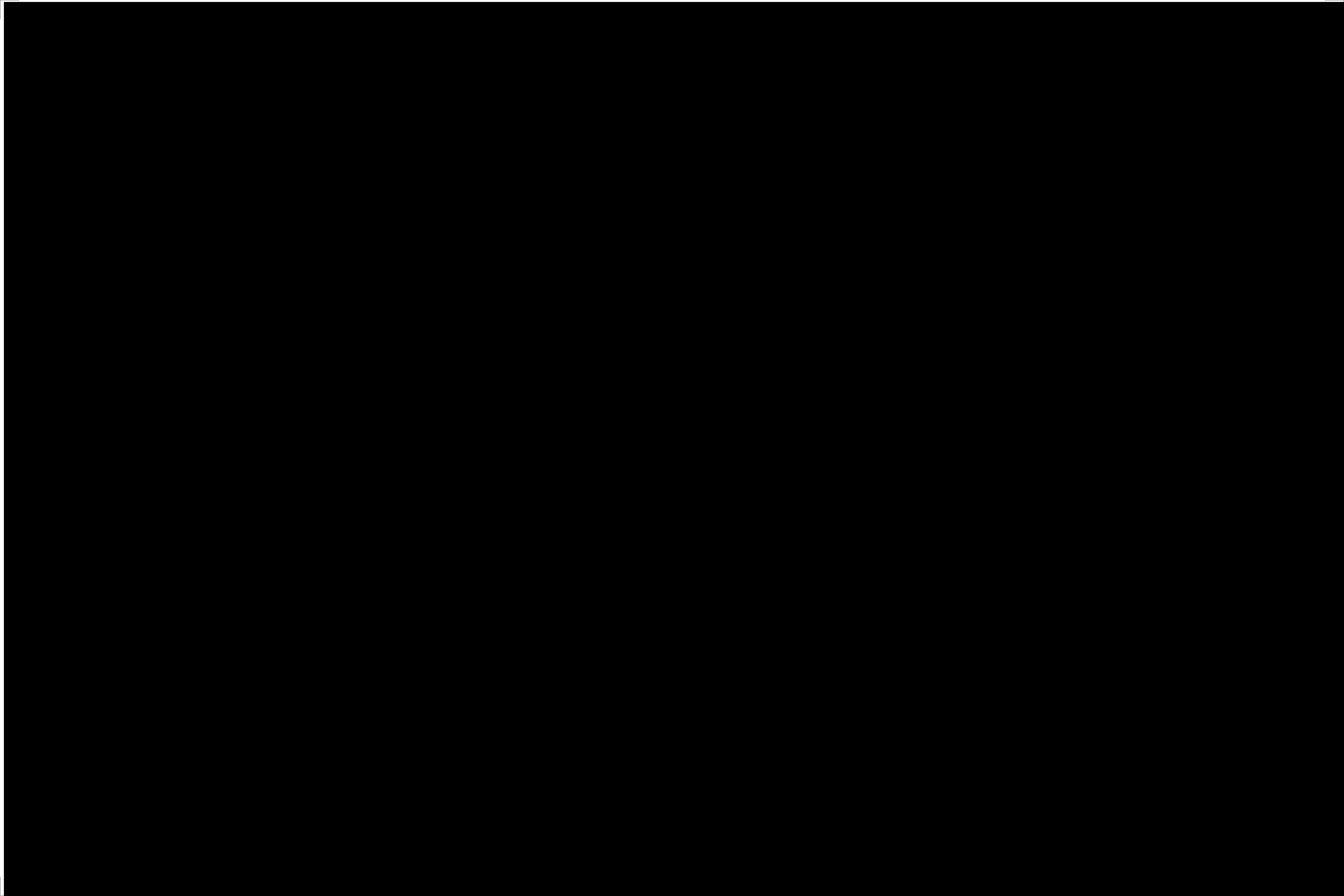
800-361-2260

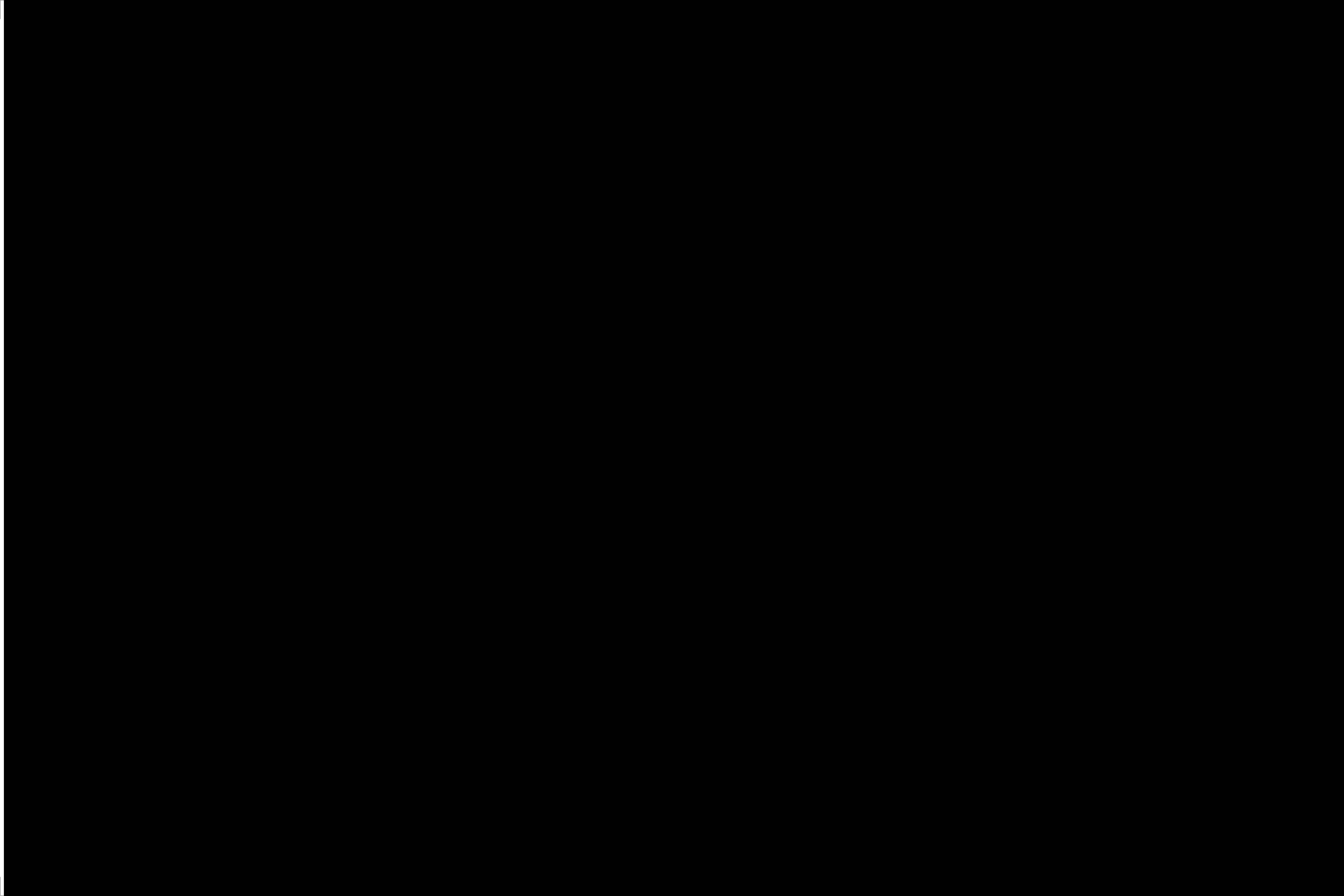
info@manaras.com

CAM #240510 manaras.com

Exhibit 3

Page 148 of 262







**Moss & Associates, LLC**  
 6363 NW 6th Way  
 Ft Lauderdale, FL 33309

May 04, 2026

Ronald Stein  
 City of Fort Lauderdale  
 101 NE 3rd Ave, Suite 2100  
 Ft. Lauderdale, FL 33301

RE: Potential Change Item (PCI) 0376 Notification  
 Fort Lauderdale Police Headquarters - B372302

Dear Ronald Stein,

This letter is to provide official notification of a potential change item (PCI) as follows:

PCI Number: 0376  
 Date: March 30, 2026  
 Description: AFIS and Body Worn Camera Outlet Changes  
 Days Requested:  
 Reason: Owner Directive - External  
 Scope Description: - HQ RM 1319 - Convert eight (8) existing splice junction boxes to duplex receptacles.  
 - HQ RM 1407 - Convert one (1) existing furniture feed jbox to quad receptacles.

Work is assumed to be completed using existing conduit and therefore drywall cutting, patching, and painting are excluded.

This PCI is comprised of the following items:

- HQ RM 1319 - Convert eight (8) existing splice junction boxes to duplex receptacles.	\$ 2,359.74
- HQ RM 1407 - Convert one (1) existing furniture feed jbox to quad receptacles.	
01 Subcontract Default Insurance 1.25%	\$ 29.50
02 Moss Insurance 1.75%	\$ 41.30
03 Bond 1%	\$ 23.60
04 Fee 4%	\$ 94.39

<b>Grand Total</b>	<b>\$2,548.53</b>
--------------------	-------------------

Per the terms and conditions of our contract, we have attached the appropriate back up documentation to substantiate the above referenced costs. This request only includes the items specifically identified in this change proposal. All other costs associated with this project shall be submitted under a separate change order cover.

Please indicate your formal approval for this additional work and cost by signing in the space provided below. Moss & Associates will then incorporate this change into the next Owner Change Order (OCO).

If you should have any questions, please contact the undersigned at 954-326-2727 as soon as possible.

<p>Sincerely,  <b>Moss &amp; Associates, LLC</b>          _____ Date: _____           Matthew Kane          Sr. Project Manager</p>	<p>Reviewed / Approved by:  <b>City of Fort Lauderdale</b>   <b>Approved:</b> _____ <b>Date:</b> _____          (Owner)</p>
---	---



RFI#  
**Project Name:** FLPD  
**Project Number:** 23-414  
**Page Number:** 1  
**Change Order #:** 83R1  
**Change Order Date:** 5/4/2026

**Moss**  
 2101 N ANDREWS AVE  
 FT LAUDERDALE, FL 33311  
 Telephone: (954) 524-5678

---

**Scope of work**

---

At the request of ownership, this change order proposal covers the labor and material associated to provide additional electrical provisions as outlined below:

- HQ RM 1319 - Convert eight (8) existing splice junction boxes to duplex receptacles.
- HQ RM 1407 - Convert one (1) existing furniture feed jbox to quad receptacles.

This proposal includes the following: - Deenergizing of associated circuit breaker at the panel.

- Removal of existing jbox/furniture feed cover and wire splices
- Installation of extension rings and 2 gang 4 inch square ring.
- Wiring/splice for added wiring devices
- installation of wall plate
- Energizing of associated circuit breaker at the panel.

This proposal excludes the following:

- Removal of access ceiling tiles.
- Demolition, relocation, protection, or removal of existing or completed millwork.
- Relocation, protection, or removal of furniture.
- Repair, core, patching, and/or painting of finishing of any surfaces impacted by the floor box covers required to complete this work.
- Concrete coring, drilling, cutting and/or backfilling.
- Any low voltage cabling, terminations, repairs and/or troubleshooting to be done by low voltage sub.
- Specialty or custom materials outside of this proposal to be provided.
- Any waterproofing.
- Accelerated schedule requirements.
- After hours and/or overtime hours.
- Permit fees.
- Clean up.

**All remedial or repair work necessary due to these changes is to be performed by others. Any unforeseen conditions, code requirements, or field conflicts discovered after work begins that impact labor or material shall be addressed via additional cost and time adjustment.**

---

**Summary**

---

**MATERIAL**

General Materials		203.86
RECEPTACLES & FACE PLATES		90.50
Material Tax	(@ 7.000 %)	20.61

**Material Total** **314.97**

**LABOR**

ELECTRICIAN	(15.74 Hrs @ \$55.00)	865.70
FOREMAN	(3.72 Hrs @ \$65.00)	241.80

Phone: 305-669-1776 Fax: 305-669-1710



RFI#  
**Project Name:** FLPD  
**Project Number:** 23-414  
**Page Number:** 2  
**Change Order #:** 83R1  
**Change Order Date:** 5/4/2026

**Moss**  
 2101 N ANDREWS AVE  
 FT LAUDERDALE, FL 33311  
 Telephone: (954) 524-5678

<b>Summary (Cont'd)</b>		
SUPERINTENDENT	(1.43 Hrs @ \$70.00)	100.10
PROJECT MANAGER	(0.49 Hrs @ \$85.00)	41.65
CLEAN UP	(8.00 Hrs @ \$52.00)	416.00
ESTIMATING	(3.00 Hrs @ \$55.00)	165.00
<b>Total Labor</b>		<b>1,830.25</b>
<b>TOTAL MATERIAL, LABOR &amp; EQUIPMENT</b>		<b>2,145.22</b>
OH&P	(@ 10.000 %)	214.52
<b>Final Amount</b>		<b>\$2,359.74</b>



**Moss**  
 2101 N ANDREWS AVE  
 FT LAUDERDALE, FL 33311  
 Telephone: (954) 524-5678

**Project Name:** FLPD  
**Project Number:** 23-414  
**Page Number:** 3  
**Change Order #:** 83R1  
**Change Order Date:** 5/4/2026

**Itemized Breakdown**

**HQ-E2-2-1B**

Description	Qty	Net Price U	Total Mat.	Labor U	Total Hrs.
4" SQ BOX EXT RING COMB KO	8	1,984.22 C	158.74	8.75 C	0.70
#8x 1/2 WAFER HEAD SHEET MTL SCREW	16	6.04 C	0.97	1.88 C	0.30
#12/2C CABLE MC - ALUM ARMOR	10	862.08 M	8.62	19.00 M	0.19
WIRE CONN RED	32	19.64 C	6.28	4.00 C	1.28
1G DECORATOR PLATE - PLASTIC IVY	8	0.00 C	0.00	3.75 C	0.30
20A 125V DUP REC - DECOR IVY (SG)	8	0.00 C	0.00	25.00 C	2.00
DEENERGIZING OF CIRCUIT BREAKER	1	0.00 E	0.00	1.00 E	1.00
ENERGIZING OF CIRCUIT BREAKER	1	0.00 E	0.00	1.00 E	1.00
REMOVAL OF EXISTING COVER PLATE AND SPLICES	8	0.00 E	0.00	0.50 E	4.00
<b>Totals</b>	<b>92</b>		<b>174.61</b>		<b>10.77</b>

**HQ-E2-2-1C**

Description	Qty	Net Price U	Total Mat.	Labor U	Total Hrs.
4" SQ BOX EXT RING COMB KO	1	1,984.22 C	19.84	8.75 C	0.09
#12/2C CABLE MC - ALUM ARMOR	10	862.08 M	8.62	19.00 M	0.19
WIRE CONN RED	4	19.64 C	0.79	4.00 C	0.16
2G DECORATOR PLATE - PLASTIC IVY	1	0.00 C	0.00	5.63 C	0.06
20A 125V DUP REC - DECOR IVY (SG)	2	0.00 C	0.00	25.00 C	0.50
DEENERGIZING OF CIRCUIT BREAKER	1	0.00 E	0.00	1.00 E	1.00
ENERGIZING OF CIRCUIT BREAKER	1	0.00 E	0.00	1.00 E	1.00
REMOVAL OF EXISTING COVER PLATE AND SPLICES	1	0.00 E	0.00	0.50 E	0.50
<b>Totals</b>	<b>21</b>		<b>29.25</b>		<b>3.49</b>

**CLIENT ACCEPTANCE**

<b>Name:</b>	
<b>Date:</b>	
<b>Signature:</b>	
I hereby accept this quotation and authorize the contractor to complete the above described work.	

Phone: 305-669-1776 Fax: 305-669-1710

# Quotation

**WORLD ELECTRIC SUPPLY, LLC**  
**2301 NW 107TH AVE**  
**STE 100**  
**DORAL, FL 33172**

**johan.santoyo@worldelectricsupply.com**

QUOTE TO:  
 THUNDER ELECTRICAL CONTRACTORS  
 7035-F SW 47TH ST  
 MIAMI, FL 33155-4639  
 305-669-1776

SHIP TO:  
 THUNDER ELECTRICAL CONTRACTORS  
 7035-F SW 47TH ST  
 MIAMI, FL 33155-4639  
 305-669-1776

QUOTE DATE	QUOTE NUMBER
03/27/26	S061684785
PAGE NO.	
1 of 2	

CUSTOMER NUMBER	CUSTOMER ORDER NUMBER	JOB NAME	QUOTED TO		
2980					
SALESPERSON	SHIP VIA	FREIGHT ALLOWED	EXPIRATION DATE		
JOHAN SANTOYO	DC12	No	11:59pm ET 04/11/26		
ORDER QTY	UPC	DESCRIPTION	UNIT PRICE	U	EXT PRICE
1ea	88377831154	HUBW P1W WALLPLATE 1G TOG WH	1.000	e	1.00
10ea	78358514430	HUBW CR20WHITR 20A COML DPLX RCPT	7.950	e	79.50
10ea	88377831327	HUBW P8W WALLPLATE 1G 1 DUP WH	1.000	e	10.00

**TERMS & CONDITIONS**

All transactions are subject to and exclusively governed by our Terms and Conditions of Sale, which are incorporated herein and available at: <https://www.worldelectricsupply.com/terms#sale>. Additional or conflicting terms are rejected, void, and of no force or effect.

<b>Subtotal</b>	<b>90.50</b>
<b>S&amp;H CHGS</b>	<b>0.00</b>
<b>Sales Tax</b>	<b>6.34</b>
<b>Amount Due</b>	<b>96.84</b>

# Quotation

**WORLD ELECTRIC SUPPLY, LLC**  
**2301 NW 107TH AVE**  
**STE 100**  
**DORAL, FL 33172**

**johan.santoyo@worldelectricsupply.com**

QUOTE DATE	QUOTE NUMBER
03/27/26	S061684785
PAGE NO.	
2 of 2	

QUOTE TO:  
 THUNDER ELECTRICAL CONTRACTORS  
 7035-F SW 47TH ST  
 MIAMI, FL 33155-4639  
 305-669-1776

SHIP TO:  
 THUNDER ELECTRICAL CONTRACTORS  
 7035-F SW 47TH ST  
 MIAMI, FL 33155-4639  
 305-669-1776

CUSTOMER NUMBER	CUSTOMER ORDER NUMBER	JOB NAME	QUOTED TO	
2980				
SALESPERSON		SHIP VIA	FREIGHT ALLOWED	EXPIRATION DATE
JOHAN SANTOYO		DC12	No	11:59pm ET 04/11/26

**Terms and Conditions of Sale for Quotes**

A. Seller assumes no responsibility whatsoever for any interpretation of bid documents, plans, or specifications provided to Seller (i.e., customer shall be solely responsible for ensuring interpretation of such documents, plans and/or specifications and for conformity and appropriateness of all goods and services ordered in comparison to same).

B. Prices are subject to change at any time prior to shipment unless otherwise agreed in writing signed by an authorized Seller representative.

C. Pricing and estimated delivery dates are based solely on the quantities and specific products and/or scope of services identified in this quote. Seller may refuse, terminate, or change pricing, estimated dates, and other terms of its offer if customer requests changes or deviations from the original quote. Unless an authorized Seller representative accepts customer's proposed deviations in an explicit signed agreement modifying this quotation, any such proposed deviations are automatically rejected, void, and of no force or effect.

D. Quotation does not include special mounting or installation hardware, equipment options, accessories, samples, spares, or mock-up equipment unless otherwise noted.

E. Seller is not responsible for the design of the project or any goods supplied.

F. Seller reserves the right to increase the pricing quoted herein to account for force majeure events, the imposition of new or increased tariffs, shipping costs, import/export fees, duties, customs, or taxes, currency fluctuations, or increases in commodity or market pricing.

G. Pre-shipment of anchor bolts is plus freight.

H. Where applicable, fabrication and shipment of goods can only be made after Seller receives the following: (i) purchase order conforming to this Quotation, (ii) customer's verification and approval of technical information, (iii) approved Submittal Drawings, and (iv) credit approval.

I. Lead times are strictly estimates. Seller is not responsible for ship dates beyond estimated dates unless Seller's President or VP Finance otherwise explicitly agrees in a signed writing as part of this Quotation and then only to the extent so agreed.

J. All orders are FCA Shipping Point, prepaid and billed, unless otherwise noted in quote.

K. Logistic solutions, storage, handling, kitting, expedited or special delivery, testing, including, but not limited to, infrared scanning and NETA testing, spares, start-up, installation, commissioning, arc flash studies, and other services are excluded unless otherwise specified in this quote. Please contact your Seller representative for additional information on any such services if desired.

L. This quotation and all related transactions are also subject to the applicable manufacturer's published warranties, including all applicable disclaimers, exclusions, and limitations.

M. This quotation constitutes Seller's confidential information, and customer shall not share or distribute this quotation to third parties other than to the extent reasonably necessary to process the transactions contemplated herein with Seller.

N. Unless otherwise expressly agreed in a separate writing signed by Seller's President or VP Finance, Seller does not agree and is not subject to any contractual flow-down or pass-through terms from customer, including, but not limited to, DFARS, FARs, Prime Contracts, Minority Business requirements, Buy America Act, etc.

## Brandon Rodriguez

---

**From:** Tiago Lima <tlima@moss.com>  
**Sent:** Wednesday, March 4, 2026 7:41 AM  
**To:** Brandon Rodriguez  
**Cc:** John-James Yancey; James Pope; Matthew Kane  
**Subject:** RE: FLPH Added Receptacles

Good Morning Brandon

Please see added receptacles list from PD. Let me know what other information you need.

### **Added Receptacles**

Body worn camera (1319)- 5 duplex receptacles-I believe this is below the power strips were there are currently blank covers.

AFIS Room (1407)- 1 quad receptacle installed in place of existing furniture feed on east wall.

Regards,

Tiago Lima  
Senior Field Engineer  
**Moss**  
Direct: 954.504.8507  
[mosscm.com](http://mosscm.com)

---

**From:** Matthew Kane <mkane@moss.com>  
**Sent:** Wednesday, March 4, 2026 7:31 AM  
**To:** Tiago Lima <tlima@moss.com>  
**Cc:** John-James Yancey <jjyancey@moss.com>; James Pope <jpope@moss.com>  
**Subject:** Re: FLPH Added Receptacles

We can do it but I know Brandon is going to ask for more information location, circuits, etc. Can you get with Brandon find out exactly what he'll need?

Sent via the Samsung Galaxy S24, an AT&T 5G smartphone  
Get [Outlook for Android](#)

---

**From:** Tiago Lima <[tlima@moss.com](mailto:tlima@moss.com)>  
**Sent:** Wednesday, March 4, 2026 7:29:06 AM  
**To:** Matthew Kane <[mkane@moss.com](mailto:mkane@moss.com)>  
**Cc:** John-James Yancey <[jjyancey@moss.com](mailto:jjyancey@moss.com)>; James Pope <[jpope@moss.com](mailto:jpope@moss.com)>  
**Subject:** FW: FLPH Added Receptacles

Morning Mr. Kane.

Let me know how you would like to proceed.

Regards,

Tiago Lima  
Senior Field Engineer  
**Moss**  
Direct: 954.504.8507  
[mosscom.com](mailto:mosscom.com)

---

**From:** Alan Ragoonanan <[ARagoonanan@flpd.gov](mailto:ARagoonanan@flpd.gov)>  
**Sent:** Tuesday, March 3, 2026 2:34 PM  
**To:** Tiago Lima <[tlima@moss.com](mailto:tlima@moss.com)>; Johnathan Jones <[JohnathanJ@flpd.gov](mailto:JohnathanJ@flpd.gov)>  
**Cc:** Ronald Stein <[rstein@fortlauderdale.gov](mailto:rstein@fortlauderdale.gov)>; Matthew Kane <[mkane@moss.com](mailto:mkane@moss.com)>; Rishi Preetam (Police) <[RPreetam@flpd.gov](mailto:RPreetam@flpd.gov)>; John-James Yancey <[jjyancey@moss.com](mailto:jjyancey@moss.com)>; James Pope <[jpope@moss.com](mailto:jpope@moss.com)>  
**Subject:** RE: FLPH Added Receptacles

**CAUTION: This email originated from outside of Moss**

Do not click links or open attachments unless you can confirm the sender and know the content is safe.  
Be careful of any attachments or links that ask for your password.

Areas for outlet are as follows to be installed

BWC room 5 outlets . Duplex  
Afis Room ,one quad outlet .

Thanks in advance



**Alan Ragoonanan | Facilities Supervisor .**  
**Support Services Bureau | Police Department**  
**City of Fort Lauderdale**  
1350 West Broward Blvd ,Fort Lauderdale ,33312  
O: 954-828-5474 | C: 954-296-5038  
E:alanra@flpd.gov  
**WeAreFTL**

---

**From:** Tiago Lima <[tlima@moss.com](mailto:tlima@moss.com)>  
**Sent:** Tuesday, March 3, 2026 8:12 AM  
**To:** Alan Ragoonanan <[ARagoonanan@flpd.gov](mailto:ARagoonanan@flpd.gov)>; Johnathan Jones <[JohnathanJ@flpd.gov](mailto:JohnathanJ@flpd.gov)>  
**Cc:** Ronald Stein <[rstein@fortlauderdale.gov](mailto:rstein@fortlauderdale.gov)>; Matthew Kane <[mkane@moss.com](mailto:mkane@moss.com)>; Rishi Preetam (Police) <[RPreetam@flpd.gov](mailto:RPreetam@flpd.gov)>; John-James Yancey <[jjyancey@moss.com](mailto:jjyancey@moss.com)>; James Pope <[jpope@moss.com](mailto:jpope@moss.com)>  
**Subject:** [EXTERNAL:CAUTION!]- FLPH Added Receptacles

**[::CAUTION!:] This email originated from *outside* The City of Fort Lauderdale. Do Not Reply, click links, or open attachments from an unknown or suspicious origin. Confirm the email address is from an expected source before taking action. Report any suspicious emails to [spamadmin@fortlauderdale.gov](mailto:spamadmin@fortlauderdale.gov)**

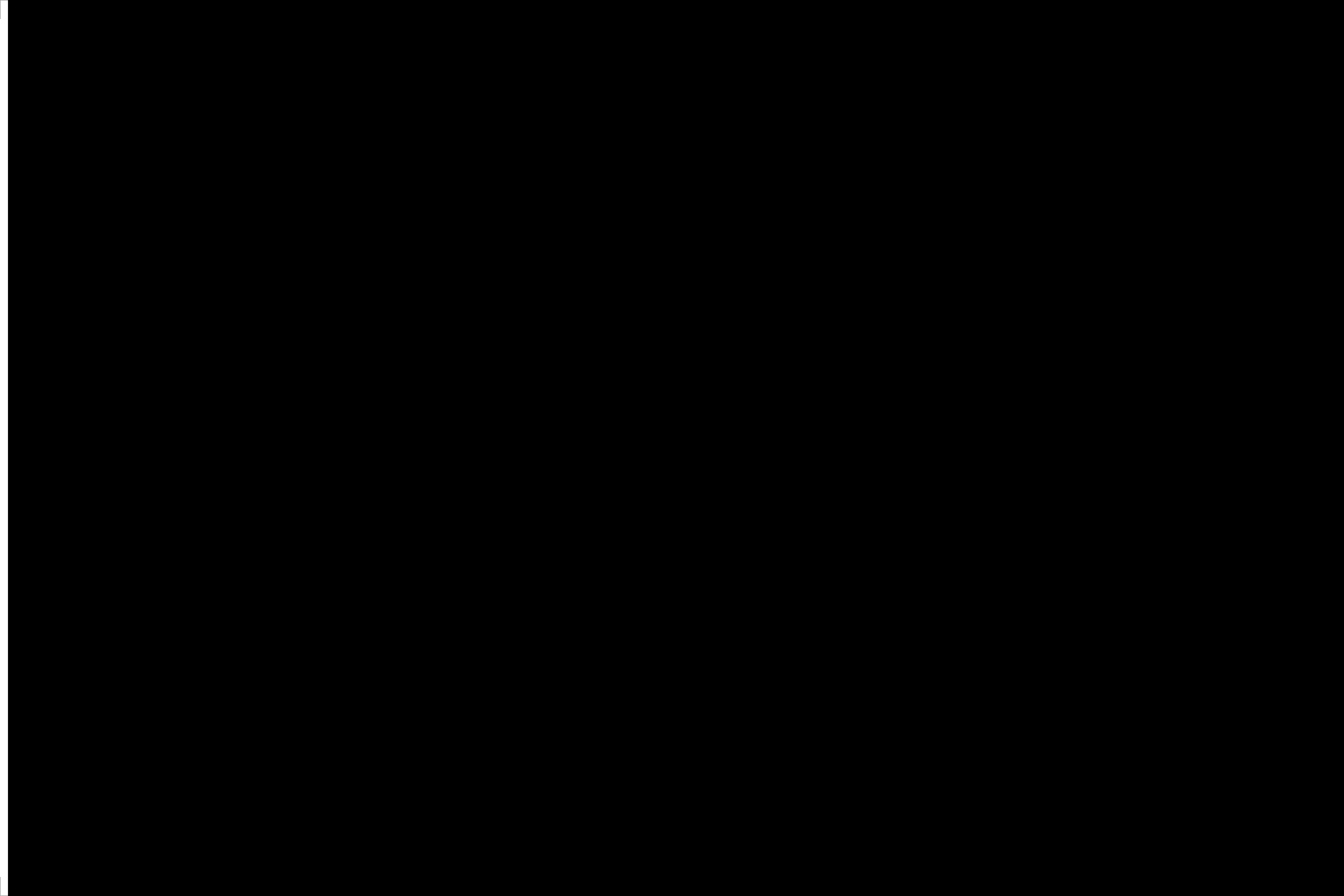
---

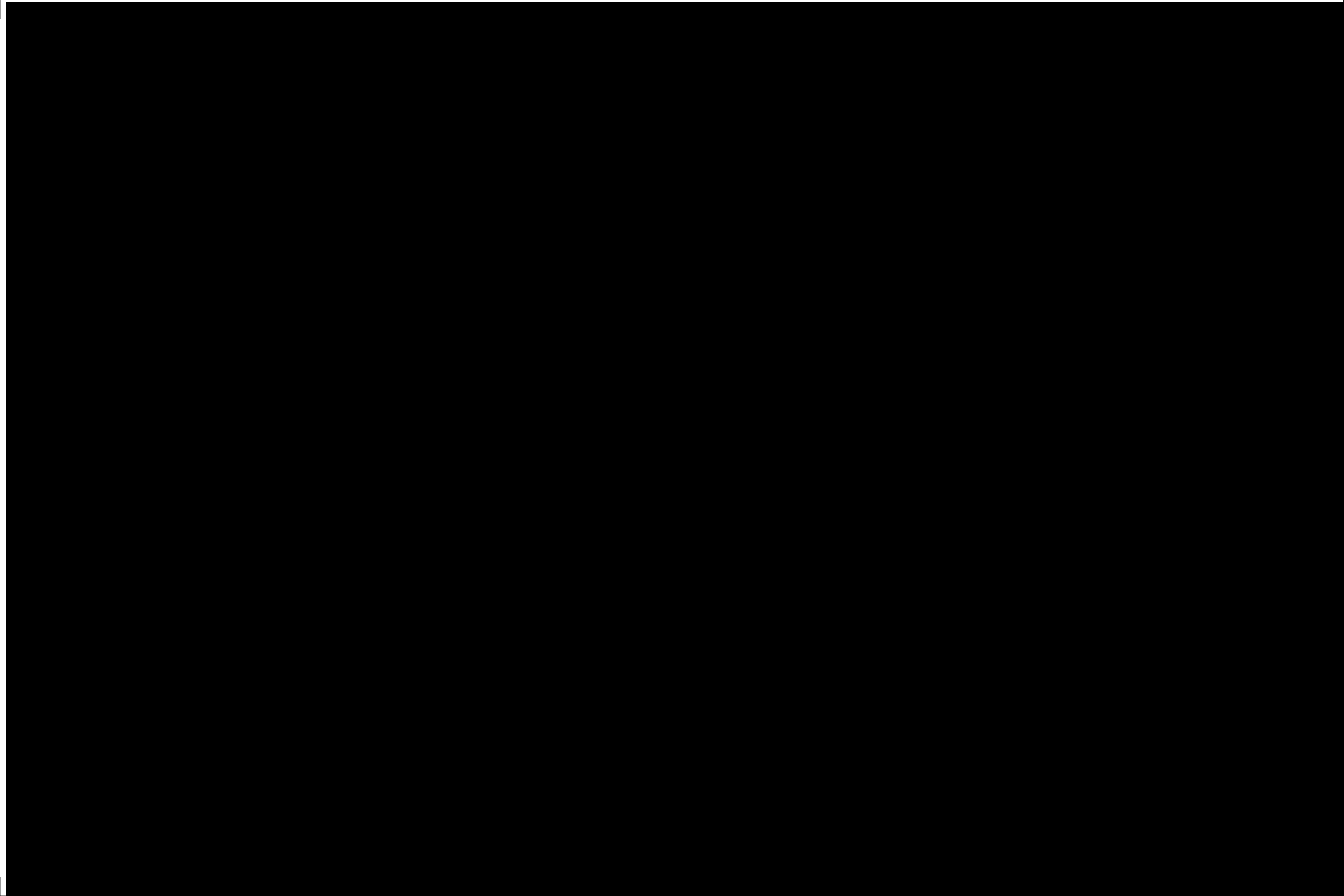
Good Morning Alan

Per our conversation, please provide quantities and locations of the added receptacles requested by PD. We can keep track of all additions in this email thread.

Regards,

Tiago Lima  
Senior Field Engineer  
**Moss**  
Direct: 954.504.8507  
[mosscm.com](http://mosscm.com)





# RM 1319 - BODY WORN CAMERA



# RM 1407 - AFIS





**Moss & Associates, LLC**  
 6363 NW 6th Way  
 Ft Lauderdale, FL 33309

May 22, 2026

Ronald Stein  
 City of Fort Lauderdale  
 101 NE 3rd Ave, Suite 2100  
 Ft. Lauderdale, FL 33301

RE: Potential Change Item (PCI) 0379 Notification  
 Fort Lauderdale Police Headquarters - B372302

Dear Ronald Stein,

This letter is to provide official notification of a potential change item (PCI) as follows:

PCI Number: 0379  
 Date: March 30, 2026  
 Description: Sally Port Overhead Controller Relocation  
 Days Requested:  
 Reason: Owner Directive - External  
 Scope Description: Supply and install (2) new push button controllers inside control room and wire to existing controller relocation. Existing controller to remain but push buttons to be deactivated.

This PCI is comprised of the following items:

COR 82R1 - Overhead door controller conduit and wire	\$ 5,000.15
(2) Manaras Station 020 Controllers	\$ 800.00
01 Subcontract Default Insurance 1.25%	\$ 72.50
02 Moss Insurance 1.75%	\$ 101.50
03 Bond 1%	\$ 58.00
04 Fee 4%	\$ 232.01
<b>Grand Total</b>	<b>\$6,264.16</b>

Per the terms and conditions of our contract, we have attached the appropriate back up documentation to substantiate the above referenced costs. This request only includes the items specifically identified in this change proposal. All other costs associated with this project shall be submitted under a separate change order cover.

The costs associated with this PCI will remain valid for fourteen (14) calendar days after submission.

Please indicate your formal approval for this additional work and cost by signing in the space provided below. Moss & Associates will then incorporate this change into the next Owner Change Order (OCO).

If you should have any questions, please contact the undersigned at 954-326-2727 as soon as possible.

<p>Sincerely,  <b>Moss &amp; Associates, LLC</b></p> <p>_____ Date: _____</p> <p>Matthew Kane          Project Manager</p>	<p>Reviewed / Approved by:  <b>City of Fort Lauderdale</b></p> <p><b>Approved:</b> _____ <b>Date:</b> _____          (Owner)</p>
--	--



**RFI#**  
**Project Name:** FLPD  
**Project Number:** 23-414  
**Page Number:** 1  
**Change Order #:** 82  
**Change Order Date:** 3/26/2026

**Moss**  
2101 N ANDREWS AVE  
FT LAUDERDALE, FL 33311  
Telephone: (954) 524-5678

---

### Scope of work

---

At the request of ownership, this time and materials ticket is for the labor and material associated with the addition of two (2) remote keypads in BOOKING COUNTER (ROOM 1810) for the Sally Port's overhead rolling doors (ROOM 1817).

Our scope of work included roughing 3/4" EMT conduit overhead from each overhead rolling door controller to the designated locations of the remote keypads inside Room 1810. We also pulled two (2) low-voltage conductors and left them for BEST Rolling Doors (BRD) to rough the keypads and terminate into both the controllers and the keypads this was completed February 4, 2026.

After completing our initial scope, BRD returned to site to terminate the wires and reported the need for a third conductor. Thunder returned on February 5, 2026 to the site to install the additional conductors.

Subsequently, the general contractor requested a third site visit to investigate an issue with the OHRD on the east side. On February 24, 2026 Thunder ground team discovered that a conductor had been incorrectly installed by BRD, with damages to the wire's protective jacket. Thunder's foreman coordinated with Moss to report this issue to BRD for correction. See photos below for reference.

This T&M includes the following scope fo work:

- Roughing 3/4" EMT conduit from OHRD controller to keypad locations
- Routing Jetline and pulling three (3) low-voltage cables
- Coordination with BEST Rolling Doors and Moss ground team for proper installation

This T&M excludes the following items:

- Removal of security access panels in RM 1810.
- Demolition, relocation, protection, or removal of existing of completed millwork.
- Relocation, protection, or removal of furniture.
- Repair, patching, and/or painting of finishing of any surfaces impacted by the floor box covers required to complete this work.
- Concrete coring, drilling, cutting and/or backfilling.
- Any low voltage cabling, terminations, repairs and/or troubleshooting to be done by low voltage sub.
- Specialty or custom materials outside of this proposal to be provided.
- Any waterproofing.
- Accelerated schedule requirements.
- After hours and/or overtime hours.
- Permit fees.
- Clean up.

**All remedial or repair work necessary due to these changes is to be performed by others. Any unforeseen conditions, code requirements, or field conflicts discovered after work begins that impact labor or material shall be addressed via additional cost and time adjustment.**



**Moss**  
 2101 N ANDREWS AVE  
 FT LAUDERDALE, FL 33311  
 Telephone: (954) 524-5678

**RFI#**  
**Project Name:** FLPD  
**Project Number:** 23-414  
**Page Number:** 2  
**Change Order #:** 82  
**Change Order Date:** 3/26/2026

---

**Summary**

---

**MATERIAL**

General Materials		897.75
Material Tax	(@ 7.000 %)	62.84

<b>Material Total</b>		<b>960.59</b>
-----------------------	--	---------------

**LABOR**

ELECTRICIAN	(30.00 Hrs @ \$55.00)	1,650.00
FOREMAN	(22.00 Hrs @ \$65.00)	1,430.00
PROJECT MANAGER	(4.00 Hrs @ \$85.00)	340.00
ESTIMATING	(2.00 Hrs @ \$55.00)	110.00
AS-BUILT DRAWINGS	(1.00 Hrs @ \$55.00)	55.00

<b>Total Labor</b>		<b>3,585.00</b>
--------------------	--	-----------------

<b>TOTAL MATERIAL, LABOR &amp; EQUIPMENT</b>		<b>4,545.59</b>
--	--	-----------------

OH&P	(@ 10.000 %)	454.56
------	--------------	--------

<b>Final Amount</b>		<b>\$5,000.15</b>
---------------------	--	-------------------



**Moss**  
 2101 N ANDREWS AVE  
 FT LAUDERDALE, FL 33311  
 Telephone: (954) 524-5678

**Project Name:** FLPD  
**Project Number:** 23-414  
**Page Number:** 3  
**Change Order #:** 82  
**Change Order Date:** 3/26/2026

**Itemized Breakdown**

**2-3-2026**

Description	Qty	Net Price U	Total Mat.	Labor U	Total Hrs.
1" DIAM CORE 6" THICK WALL	1	170.00 E	170.00	0.00 E	0.00
3/4" CONDUIT - EMT	95	154.78 C	147.04	4.40 C	0.00
3/4" COUPLING COMP STL - EMT	10	424.55 C	42.45	37.50 C	0.00
3/4" CONN COMP STL INSUL - EMT	6	471.66 C	28.30	15.63 C	0.00
3/4" LOCKNUT - STEEL	4	51.00 C	2.04	2.88 C	0.00
3/4" 1-H STRAP - EMT - STEEL	12	51.58 C	6.19	6.75 C	0.00
4x 2 1/8" SQ BOX 3/4" KO	1	2,481.91 C	24.82	28.75 C	0.00
4" SQ BLANK COVER	1	546.28 C	5.46	3.13 C	0.00
#10x 1 P/H SELF-TAP SCREW	12	12.00 C	1.44	3.75 C	0.00
3/16x 1 1/4 CONCRETE SCREW HEX HEAD - BLUE	12	45.53 C	5.46	8.50 C	0.00
1/4x 1 3/4 CONCRETE SCREW HEX HEAD - BLUE	2	69.08 C	1.38	10.75 C	0.00
#14 THHN BLACK	109	161.19 M	17.57	5.38 M	0.00
#14 THHN RED	109	161.19 M	17.57	5.38 M	0.00
1/8" POLYTWINE	109	11.94 M	1.30	3.75 M	0.00
ELECTRICIAN	16	0.00 E	0.00	1.00 E	16.00
FOREMAN	8	0.00 E	0.00	1.00 E	8.00
<b>Totals</b>	<b>507</b>		<b>471.03</b>		<b>24.00</b>

**2-4-2026**

Description	Qty	Net Price U	Total Mat.	Labor U	Total Hrs.
1" DIAM CORE 6" THICK WALL	1	170.00 E	170.00	0.00 E	0.00
3/4" CONDUIT - EMT	65	154.78 C	100.61	4.40 C	0.00
3/4" COUPLING COMP STL - EMT	6	424.55 C	25.47	37.50 C	0.00
3/4" CONN COMP STL INSUL - EMT	6	471.66 C	28.30	15.63 C	0.00
3/4" LOCKNUT - STEEL	2	51.00 C	1.02	2.88 C	0.00
3/4" 1-H STRAP - EMT - STEEL	9	51.58 C	4.64	6.75 C	0.00
4x 2 1/8" SQ BOX 3/4" KO	1	2,481.91 C	24.82	28.75 C	0.00
4" SQ BLANK COVER	1	546.28 C	5.46	3.13 C	0.00
#10x 1 P/H SELF-TAP SCREW	9	12.00 C	1.08	3.75 C	0.00
3/16x 1 1/4 CONCRETE SCREW HEX HEAD - BLUE	9	45.53 C	4.10	8.50 C	0.00
1/4x 1 3/4 CONCRETE SCREW HEX HEAD - BLUE	4	69.08 C	2.76	10.75 C	0.00
#14 THHN BLACK	78	161.19 M	12.57	5.38 M	0.00
#14 THHN RED	78	161.19 M	12.57	5.38 M	0.00

Phone: 305-669-1776 Fax: 305-669-1710



**Moss**  
 2101 N ANDREWS AVE  
 FT LAUDERDALE, FL 33311  
 Telephone: (954) 524-5678

**Project Name:** FLPD  
**Project Number:** 23-414  
**Page Number:** 4  
**Change Order #:** 82  
**Change Order Date:** 3/26/2026

Description	Qty	Net Price U	Total Mat.	Labor U	Total Hrs.
1/8" POLYTWINE	78	11.94 M	0.93	3.75 M	0.00
ELECTRICIAN	6	0.00 E	0.00	1.00 E	6.00
FOREMAN	6	0.00 E	0.00	1.00 E	6.00
<b>Totals</b>	<b>359</b>		<b>394.34</b>		<b>12.00</b>

**2-5-2026**

Description	Qty	Net Price U	Total Mat.	Labor U	Total Hrs.
#14 THHN PURPLE	187	161.19 M	30.14	5.38 M	0.00
1/8" POLYTWINE	187	11.94 M	2.23	3.75 M	0.00
ELECTRICIAN	4	0.00 E	0.00	1.00 E	4.00
FOREMAN	4	0.00 E	0.00	1.00 E	4.00
<b>Totals</b>	<b>382</b>		<b>32.38</b>		<b>8.00</b>

**2-24-2026**

Description	Qty	Net Price U	Total Mat.	Labor U	Total Hrs.
ELECTRICIAN	4	0.00 E	0.00	1.00 E	4.00
FOREMAN	4	0.00 E	0.00	1.00 E	4.00
<b>Totals</b>	<b>8</b>		<b>0.00</b>		<b>8.00</b>

**CLIENT ACCEPTANCE**

<b>Name:</b>	_____
<b>Date:</b>	_____
<b>Signature:</b>	_____
I hereby accept this quotation and authorize the contractor to complete the above described work.	

## Brandon Rodriguez

---

**From:** Matthew Kane <mkane@moss.com>  
**Sent:** Wednesday, December 10, 2025 3:06 PM  
**To:** Pedro J. Hernandez; Brandon Rodriguez  
**Cc:** Ronald Stein; Jimmy Lorenzo; John-James Yancey; Tiago Lima  
**Subject:** RE: Site LV Conduits  
**Attachments:** RFI-491-Confirmation\_If\_HQ\_Telecommunication\_Site\_Plan\_Response.pdf

Thanks Ron. My notes/directive to Thunder is as follows:

- Keep HH-7 and extend conduit to west on RFI 491 drawing. All other highlighted conduit still to be deleted.
- Thunder to use credit for deleted conduit to offset cost of added conduit on attached and the additional temp shelter work. These pending COR's are void
- Thunder to proceed with power and data relocations (COR #73) and jail camera relocation (COR #68) which are preliminary approved and pending final Commission approval.
  - Jail camera relocation pending final location drawing to begin work.
- Thunder to proceed on T&M to relocate overhead door controllers for detention sally port to control room and COR to be submitted by Moss to City. Final location of cameras from PD is also pending to start work.

Let me know if missed anything or if any above is incorrect, thanks.

Matthew Kane  
Project Manager  
**Moss**  
Cell: 321.427.3500  
[moss.com](http://moss.com)

---

**From:** Ronald Stein <RStein@fortlauderdale.gov>  
**Sent:** Wednesday, December 10, 2025 1:23 PM  
**To:** Matthew Kane <mkane@moss.com>; Pedro <pedro@thunder-electric.com>; Brandon Rodriguez <brandon@thunder-electric.com>  
**Subject:** Site LV Conduits

**CAUTION: This email originated from outside of Moss**

Do not click links or open attachments unless you can confirm the sender and know the content is safe.  
Be careful of any attachments or links that ask for your password.

All  
Attached is a copy of the plan we reviewed at yesterday's meeting.  
Thanks  
Ron

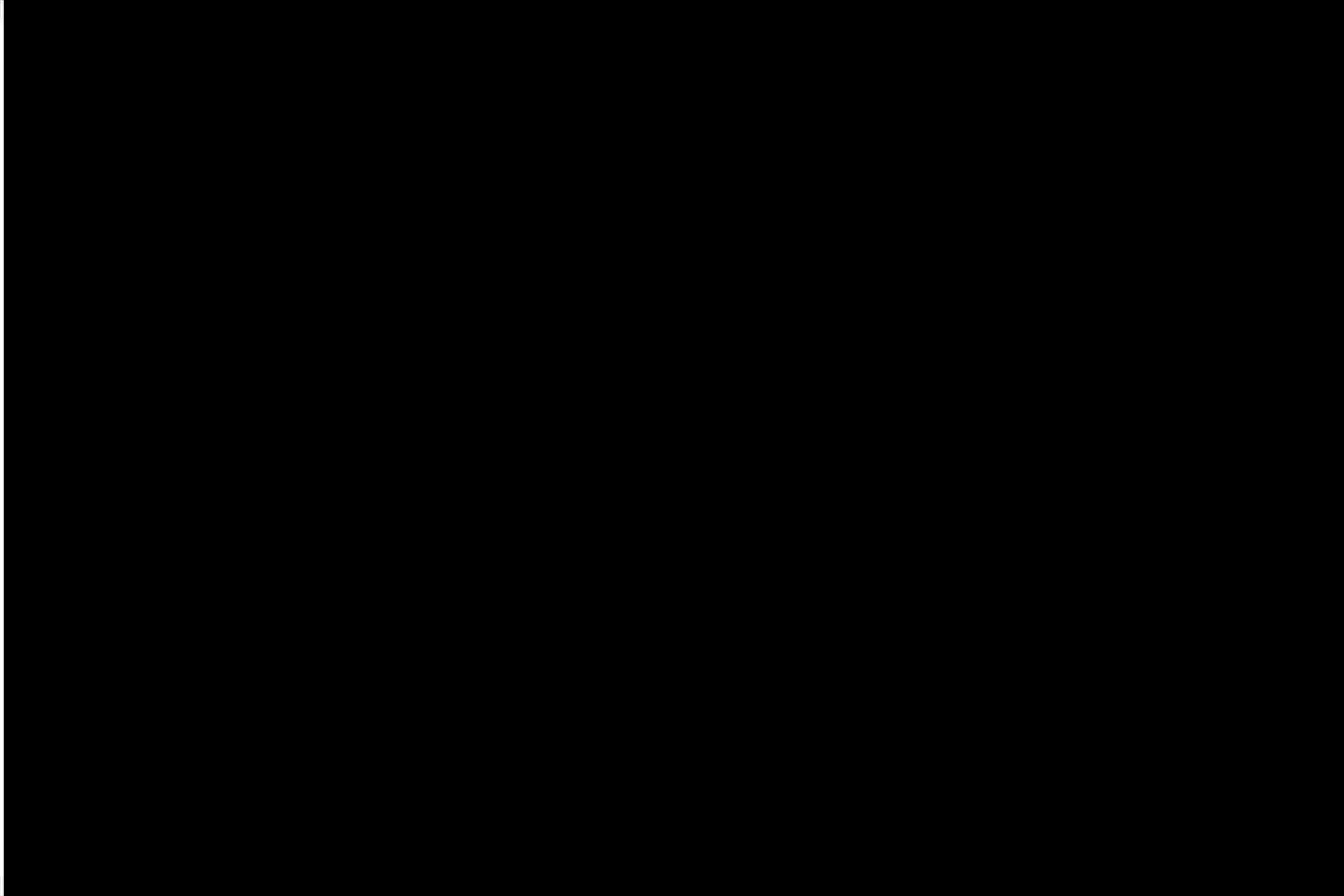
**Ronald Stein**  
**Sr. Project Manager**  
101 NE 3<sup>rd</sup> Ave, Suite 2100 | Fort Lauderdale FL 33301  
City of Fort Lauderdale  
C: (954) 531-2395 | E: [RStein@fortlauderdale.gov](mailto:RStein@fortlauderdale.gov)

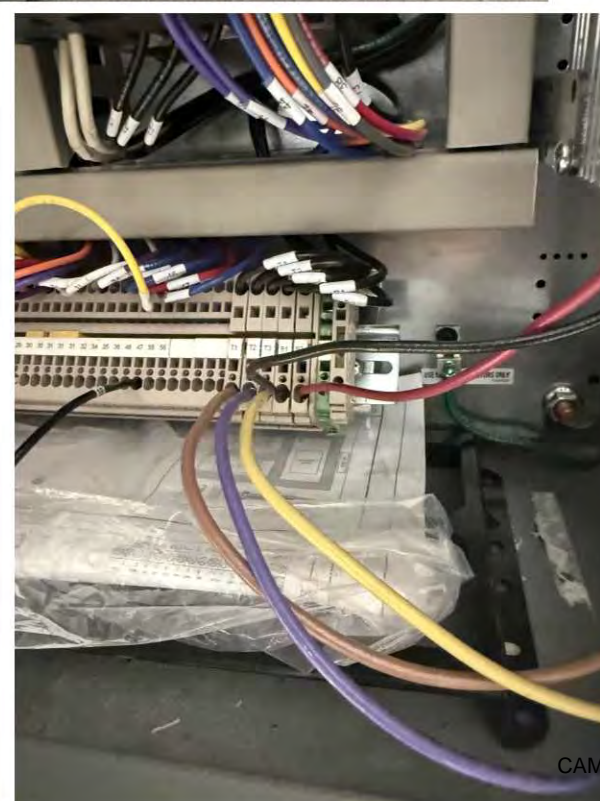
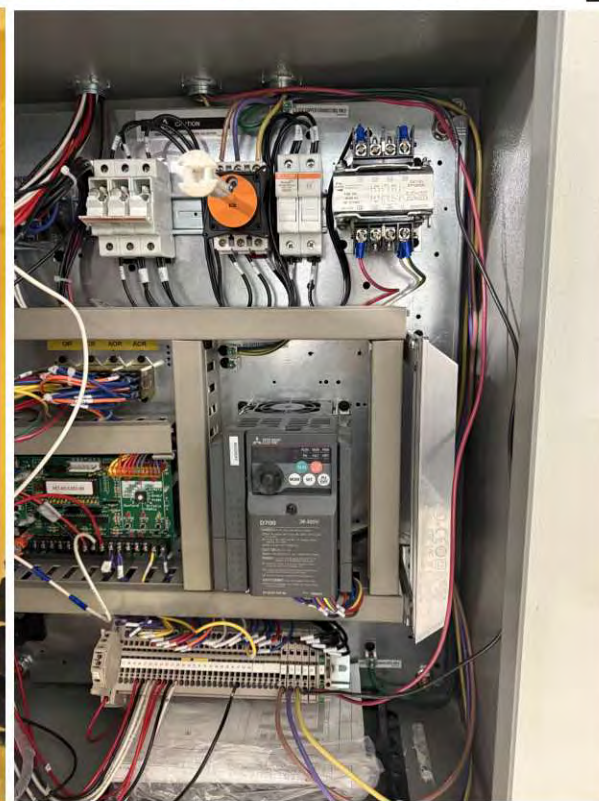
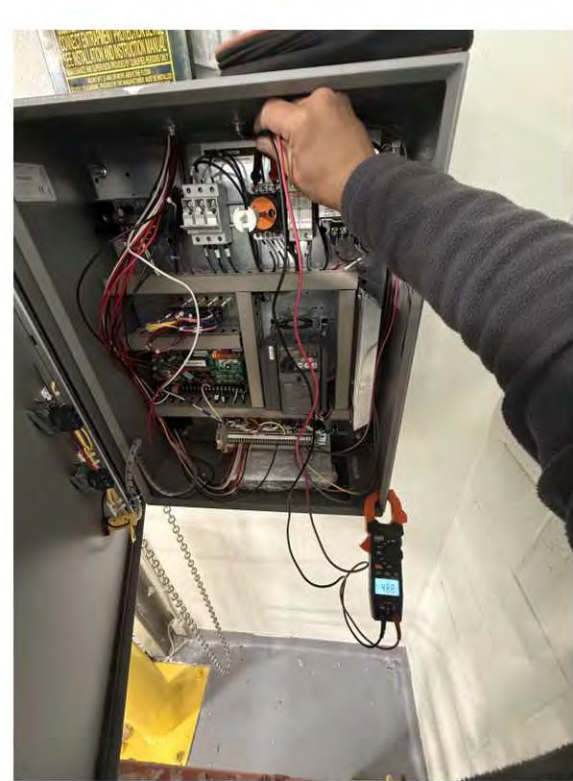
## Brandon Rodriguez

---

**From:** Matthew Kane <mkane@moss.com>  
**Sent:** Wednesday, January 28, 2026 10:50 AM  
**To:** Brandon Rodriguez; Pedro J. Hernandez; Vanessa Acosta  
**Cc:** John-James Yancey; James Pope; Tiago Lima  
**Subject:** FLPH Booking Bay Door Controllers  
**Attachments:** HQ-A2-2-1D\_ HEADQUARTERS BLDG - FLOOR PLAN LEVEL 1 - AREA D Rev.4  
markup.pdf

Brandon/Vanessa, please proceed with the attached on T&M. Vanessa, please confirm which model push button you have on hand. I included Station 20 for reference. Thunder will be installing these conduits Friday so plan on mounting controllers and running wires next week.





Job name & number: FLPD HQ - B372302

 Date: 02-03-2026

 Task performed under directive: Rollup door Controller Sally Port - Ownership

PO #: \_\_\_\_\_

DATE OF SERVICE	LABOR CLASSIFICATION	DESCRIPTION	QTY.	HOURS
02-03-2026	Electricians	Conduit, box and wire rough provisions	2	8
	Foreman		1	8
	EQUIPMENT/MATERIAL	DESCRIPTION	QTY.	HOURS
02-03-2026	Concrete drill bit for rotary hammer		1	
02-03-2026	3/4" EMT Conduit		95	
02-03-2026	3/4" EMT connector		4	
02-03-2026	3/4" EMT couplings		10	
02-03-2026	3/4" 1-H STRAP for EMT Conduit		12	
02-03-2026	Tapcon anchor screws		14	

**ADDITIONAL COMMENTS**

PAGE 1 of 2

 Prepared By: Brandon A Rodriguez

 Acknowledged by: \_\_\_\_\_  
 General Contractor

 Date: 02-03-2026

Date: \_\_\_\_\_

Job name & number: FLPD HQ - B372302

 Date: 02-03-2026

 Task performed under directive: Rollup door Controller Sally Port - Ownership

PO #: \_\_\_\_\_

DATE OF SERVICE	LABOR CLASSIFICATION	DESCRIPTION	QTY.	HOURS
	EQUIPMENT/MATERIAL	DESCRIPTION	QTY.	HOURS
02-03-2026	4" DEEP SQUARE BOX & BLANK COVER		1	
02-03-2026	1/8" POLYTWINE		109	
02-03-2026	#14 THHN Wire Black		109	
02-03-2026	#14 THHN Wire Red		109	
02-03-2026	3/4" LOCKNUT		4	

**ADDITIONAL COMMENTS**

PAGE 2 of 2

 Prepared By: Brandon A Rodriguez

 Acknowledged by: \_\_\_\_\_  
 General Contractor

 Date: 02-03-2026

Date: \_\_\_\_\_

Job name & number: FLPD HQ - B372302

 Date: 02-04-2026

 Task performed under directive: Rollup door Controller Sally Port - Ownership

PO #: \_\_\_\_\_

DATE OF SERVICE	LABOR CLASSIFICATION	DESCRIPTION	QTY.	HOURS
02-04-2026	Electricians	Conduit, box and wire rough provisions	2	6
	Foreman		1	6
	EQUIPMENT/MATERIAL	DESCRIPTION	QTY.	HOURS
02-04-2026	Concrete drill bit for rotary hammer		1	
02-04-2026	3/4" EMT Conduit		70	
02-04-2026	3/4" EMT connector		8	
02-04-2026	3/4" EMT couplings		4	
02-04-2026	3/4" 1-H STRAP for EMT Conduit		9	
02-04-2026	Tapcon anchor screws		13	

**ADDITIONAL COMMENTS**

PAGE 1 of 2

 Prepared By: Brandon A Rodriguez

 Acknowledged by: \_\_\_\_\_  
 General Contractor

 Date: 02-04-2026

Date: \_\_\_\_\_

Job name & number: FLPD HQ - B372302

 Date: 02-04-2026

 Task performed under directive: Rollup door Controller Sally Port - Ownership

PO #: \_\_\_\_\_

DATE OF SERVICE	LABOR CLASSIFICATION	DESCRIPTION	QTY.	HOURS
	EQUIPMENT/MATERIAL	DESCRIPTION	QTY.	HOURS
02-04-2026	4" DEEP SQUARE BOX & BLANK COVER		1	
02-04-2026	1/8" POLYTWINE		78	
02-04-2026	#14 THHN Wire Black		78	
02-04-2026	#14 THHN Wire Red		78	
02-04-2026	3/4" LOCKNUT		2	

**ADDITIONAL COMMENTS**

PAGE 2 of 2

 Prepared By: Brandon A Rodriguez

 Acknowledged by: \_\_\_\_\_  
 General Contractor

Date: \_\_\_\_\_

Date: \_\_\_\_\_





**Best Rolling Doors, Inc.**  
 9780 N.W. 79 Avenue  
 Hialeah Gardens, FL 33016  
 (305)-821-6607

# Quote

Customer No.: ESTIMATOR3  
 Quote No.: 11214

Quote To: **MOSS CONSTRUCTION**  
 FORT LAUDERDAL POLICE HQ

Ship To: **ESTIMATING DEPARTMENT**

Date	Ship Via	F.O.B.	Terms
02/04/2026		Origin	C.O.D.
Purchase Order Number	Sales Person		Required
	Vanessa Acosta		02/04/2026
Quantity			Amount
Required	Shipped	B.O.	
Item Number	Description		Unit Price

**COMMERCIAL SERVICE**

2		Manaras STATION 020 Includes Install & Program	400.00	800.00
		Quote subtotal		800.00
		Quote total		800.00

WE APPRECIATE YOUR BUSINESS !!

Thank You



**Moss & Associates, LLC**  
 6363 NW 6th Way  
 Ft Lauderdale, FL 33309

April 09, 2026

Ronald Stein  
 City of Fort Lauderdale  
 101 NE 3rd Ave, Suite 2100  
 Ft. Lauderdale, FL 33301

RE: Potential Change Item (PCI) 0384 Notification  
 Fort Lauderdale Police Headquarters - B372302

Dear Ronald Stein,

This letter is to provide official notification of a potential change item (PCI) as follows:

PCI Number: 0384  
 Date: April 09, 2026  
 Description: Additional Data Jacks per PD Request  
 Days Requested:  
 Reason: Owner Directive - External  
 Scope Description: Additional data jacks by LV cabling contractor:  
 IT Office - (4) in storage, (1) for copier,  
 (4) in rear of suite

Chief's Office (1) for Fax

Assumes freewire above ceiling and within walls to cut-in box therefore no conduit or drywall patching/painting is included.

This PCI is comprised of the following items:

Additional data jacks by LV cabling contractor: IT Office - (4) in storage, (1) for copier, (4) in rear of suite	\$ 6,191.94
Chief's Office (1) for Fax	
01 Subcontract Default Insurance 1.25%	\$ 77.40
02 Moss Insurance 1.75%	\$ 108.36
03 Bond 1%	\$ 61.92
04 Fee 4%	\$ 247.68

<b>Grand Total</b>	<b>\$6,687.30</b>
--------------------	-------------------

Per the terms and conditions of our contract, we have attached the appropriate back up documentation to substantiate the above referenced costs. This request only includes the items specifically identified in this change proposal. All other costs associated with this project shall be submitted under a separate change order cover.

We respectfully reserve our rights to request additional time should it become evident that this work will impact the overall completion of the project. The costs associated with this PCI will remain valid for fourteen (14) calendar days after submission.

Please indicate your formal approval for this additional work and cost by signing in the space provided below. Moss & Associates will then incorporate this change into the next Owner Change Order (OCO).

If you should have any questions, please contact the undersigned at 954-326-2727 as soon as possible.

<p>Sincerely, <b>Moss &amp; Associates, LLC</b></p> <p>_____ Date: _____</p> <p>Matthew Kane Project Manager</p>	<p>Reviewed / Approved by: <b>City of Fort Lauderdale</b></p> <p><b>Approved:</b> _____ <b>Date:</b> _____ (Owner)</p>
--	--



Date: 3/27/2026

PROPOSAL NO: 210276 CO18	SUBMITTED TO: Matthew Kane
Moss & Associates LLC 2101 N. Andrews Ave. Ft. Lauderdale, Fl. 33311	<i>Job Location:</i> Ft. Lauderdale Police Dept. 1300 West Broward Blvd. Ft. Lauderdale, Fl. 33312
Phone Number: 321.427.3500	Email: mkane@mosscom.com

### Additional Cables for Copier, Fax & Computer Workstation

Quantity	Part #	Manufacture	Description	Material Cost	Unit	Totals	10% Overhead and Profit	Totals
60	Hourly Rate	Jade	Technician - Regular Time	\$87.000	HR	\$ 5,220.00		\$ 5,220.00
2100	10136226	Berk-Tek	Cat6 Plenum Cable	\$0.260	EA	\$ 546.00	\$54.60	\$600.600
20	61110-RL6	Leviton	Cat6 Jacks Blue	\$5.250	EA	\$ 105.00	\$10.50	\$115.500
10	62460-07L	Leviton	7' Cat6 Patch Cable	\$9.000	EA	\$ 90.00	\$9.00	\$99.000
10	62460-03L	Leviton	3" Cat6 Patch Cable	\$6.000	EA	\$ 60.00	\$6.00	\$66.000
2	42080-4WS	Leviton	4 Port Faceplates	\$1.800	EA	\$ 3.60	\$0.36	\$ 3.96
2	42080-2WS	Leviton	2 Port Face plates	\$1.520	EA	\$ 3.04	\$0.30	\$3.344
20	CAT32HP	Caddy	2" J-Hooks	\$3.250	EA	\$ 65.00	\$6.50	\$ 71.50
10	Test	Jade	Test Cat 6/6A Cables	\$0.250	EA	\$ 2.50	\$0.25	\$ 2.75
4	LV1	Carlton	Low Voltage mounting Bracket	\$2.110	EA	\$ 8.44	\$0.84	\$9.284
								\$ 6,191.94

We hereby propose to furnish labor and materials-complete in accordance with the above specifications, for the sum of \$ **6,191.94**

***Balance due upon receipt of invoice.***

All material is guaranteed to be as specified. All work above to be completed in a skillful manner according to standard practices. Any alteration or deviation from above specifications involving extra cost, will be executed only upon written orders, and will become a "T & M" extra charge over and above the estimate. All agreements are contingent upon strikes, accidents or delays beyond our control. No permit fees or bonding is included in this quotation. This proposal is subject to acceptance within thirty days and is void hereafter at the option of the undersigned. Florida License ES0000112. Pricing includes all sales tax.

**AUTHORIZED NAME**      Serge Leblanc      3/27/2026

### **ACCEPTANCE OF PROPOSAL**

The above prices, specifications and conditions are hereby accepted. You are authorized to do the work as specified. Payment will be made as outlined above.

ACCEPTED:

Signature \_\_\_\_\_ Date \_\_\_\_\_

6610 E. ROGERS CIRCLE ° BOCA RATON, FLORIDA 33487 ° (561) 997-8552 ° FAX (561) 997-5935



**Moss & Associates, LLC**  
 6363 NW 6th Way  
 Ft Lauderdale, FL 33309

May 04, 2026

Ronald Stein  
 City of Fort Lauderdale  
 101 NE 3rd Ave, Suite 2100  
 Ft. Lauderdale, FL 33301

RE: Potential Change Item (PCI) 0385 Notification  
 Fort Lauderdale Police Headquarters - B372302

Dear Ronald Stein,

This letter is to provide official notification of a potential change item (PCI) as follows:

PCI Number: 0385  
 Date: April 09, 2026  
 Description: Misc. Fencing Changes per PD Request  
 Days Requested:  
 Reason: Owner Directive - External  
 Scope Description: This PCI includes the following:  
 -Add 600' green vinyl chain link fencing to separate west side of property from existing fleet  
 -Create a sally port enclosure with 91' of Echelon II fencing with 20' cantilever slide gate  
 -Add (2) 4' man gates to existing fencing  
 -Add (6) receivers for slide gate operator by remote control to be provided and programmed by Owner access control vendor.

Price based on sketch received 2/24/26. Permitted documents from design team have not been provided, however will be required for final inspection and CO. Includes assumptions for power requirements for slide gate operator. Contractors will endeavor to remove minimum amount of landscaping required to facilitate the work however that amount is not quantifiable and therefore replacement of landscaping is not included and assumed to be by others. Fence material currently carries an (8) week lead time and will require PCI approval by May 19th, 2026 in order to complete added scope before September 28th, 2026 Substantial Completion date per PCI 339.

This PCI is comprised of the following items:

-Add 600' green vinyl chain link fencing to separate west side of property from existing fleet	\$ 64,197.00
-Create a sally port enclosure with 91' of Echelon II fencing with 20' cantilever slide gate	\$ 101,643.00
-Add (2) 4' man gates to existing fencing	
-Add (6) receivers for slide gate operator by remote control to be provided and programmed by Owner access control vendor.	
COR 84R1 Power for additional slide gate operator at new sally port	\$ 17,661.11
01 Subcontract Default Insurance 1.25%	\$ 2,293.76
02 Moss Insurance 1.75%	\$ 3,211.27
03 Bond 1%	\$ 1,835.01
04 Fee 4%	\$ 7,340.04

<b>Grand Total</b>	<b>\$198,181.19</b>
--------------------	---------------------

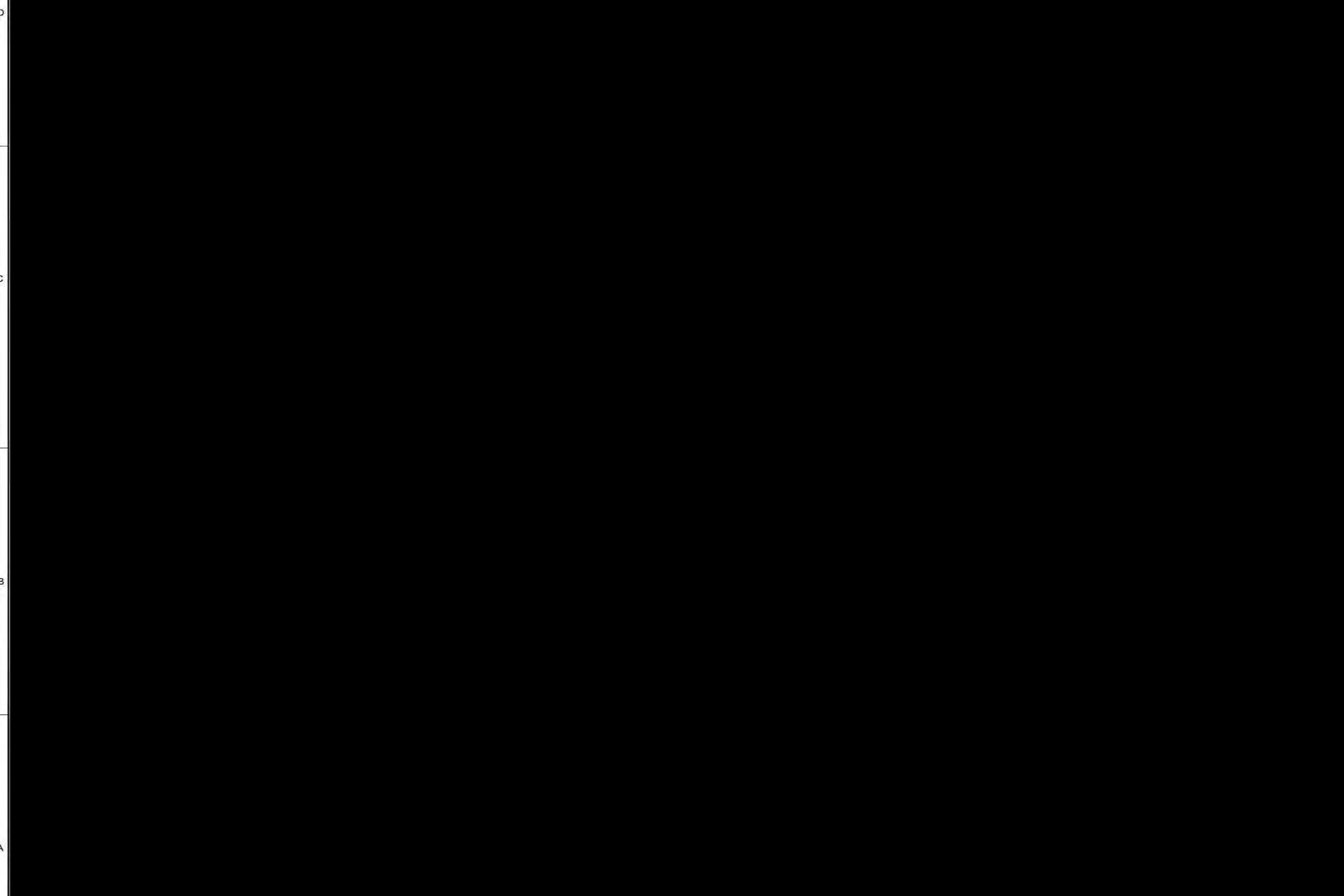
Per the terms and conditions of our contract, we have attached the appropriate back up documentation to substantiate the above referenced costs. This request only includes the items specifically identified in this change proposal. All other costs associated with this project shall be submitted under a separate change order cover.

The costs associated with this PCI will remain valid for fourteen (14) calendar days after submission.

Please indicate your formal approval for this additional work and cost by signing in the space provided below. Moss & Associates will then incorporate this change into the next Owner Change Order (OCO).

If you should have any questions, please contact the undersigned at 954-326-2727 as soon as possible.

<p>Sincerely, <b>Moss &amp; Associates, LLC</b></p> <p>_____ Date: _____</p> <p>Matthew Kane Sr. Project Manager</p>	<p>Reviewed / Approved by: <b>City of Fort Lauderdale</b></p> <p><b>Approved:</b> _____ <b>Date:</b> _____ (Owner)</p>
--	--



# FENCE MASTERS, INC.

3550 N. W. 54<sup>TH</sup> STREET  
MIAMI, FLORIDA 33142

DADE: (305)635-7777 \* BROWARD (954)463-3172 \* FAX: (305)635-7887

<b>Date:</b>	<b>May 18, 2026</b>	<b>Name:</b>	<b>Mathew Kane</b>
<b>Company:</b>	<b>Moss &amp; Associates</b>	<b>Job Name:</b>	<b>Ft Lauderdale police HQ change order</b>
<b>Address:</b>	<b>2101 N Andrews Ave., Suite #300</b>		
<b>City:</b>	<b>Ft. Lauderdale, FL 33311</b>	<b>Job Address:</b>	<b>FT Lauderdale</b>
<b>Phone:</b>	<b>954-769-8055, Fax: 954-712-5999</b>		

*We propose, subject to acceptance by Fence Masters, Inc., (seller) to perform work in accordance with quantities and sizes listed below. Before erection is begun, purchaser is to establish property line stakes and grade stakes and to remove all obstructions that may interfere with erection. Purchaser is responsible for location of any underground lines. Fence Masters, Inc. is not responsible for any damage to unmarked lines. After the contract is executed and received by Fence Masters, Inc., notice to proceed is to be provided by purchaser at least 14 days prior to date of commencement of the work. In order to avoid unforeseen conflicts in contract language, by signing this contract you are waiving any obligation on our part to sign any contract or other document that you subsequently may offer, provide, or demand. This contract will be the only contract for this job and is binding for both parties.*

Change order add as follows.

Furnish & install

Area # 1: Add 600' of 8' high green vinyl chain link fence with no gates as follows.

- 1) 9 Gauge fusion bonded 2" mesh.
- 2) 3" Posts set in concrete footings 12 by 53 to match original chain link fence specifications.
- 3) 1 5/8" top, middle, and bottom rails.
- 4) GC to provide GPR and soft digging if needed.

Green vinyl fence \$ 16,625.00 (See attached back up)

Concrete and equipment for 12 by 53 footings  
\$ 9,236.00

Material cost \$ \$ 25,861.00

Labor \$ 32,500.00 (4 man crew for 130 hrs @ \$250/hr)

10% overhead and profit \$ 5,836.00

Add \$ 64,197.00

Area # 2: Create a sally port enclosure with 8' high Ameristar Echelon II fence to match original perimeter fence.

- 1) Add 91' of 8' high Ameristar Echelon II to match existing at new Sally Port entrance.
- 2) All posts 4" square in 16" by 53" long footings.
- 3) 2 - 4' Standard Echelon II man gates with standard fork latches.
- 4) Add 1 - 20' TyMetal cantilever slide gate. GC to verify there will be enough room for gate to egress. Overall gate length will be 30'.
- 5) Add 1 - TyMetal operator with safety and free exit loops included.
- 6) All access controls, high voltage wiring and final hook up by others.
- 7) Add 6 - Receivers to all operators for access controls by others.

Slide Gate: \$36,083 (See attached back up)

Additional costs: Concrete pad \$ 160.00

5 - 6 5/8" Schedule 40 gate posts @ 375.00 each Add \$ 1,875.00

Concrete \$ 512.00

Loops \$ 525.00

Ground rod \$ 175.00

91' Fencing @ \$210/LF: \$ 19,110

Concrete: \$ 9,213

Labor \$ 24,750.00 (4 man crew for 99 hrs @ \$250/hr)

10% Overhead & profit \$ 9,240.00

Add 101,643.00

**Total Add \$ 165,840.00**

Note: The above pricing is good for only 5 days due to the existing conditions in the steel industry. The mills won't guarantee the pricing to us for more than 5 days. After that, actual price is based on receipt date of executed contract and mill price increases.

**DEPOSIT N/A**

*Subject to credit approval by Fence Masters, Inc. Terms are net on billing. Prices for this proposal are valid for 5 days from the proposal date. Interest of 1 ½ % per month will be charged on accounts past due. Title to the property as addressed by this proposal shall remain in the seller, Fence Masters, Inc. until payment in full is received, pursuant to the terms hereof. This is a retain title contract.*

*In the event the money due hereunder, or any portion thereof, has to be collected on demand of an attorney or by suit, the purchaser agrees to pay all costs of collection including interest at the highest legal rate and reasonable attorney's fees.*

Approved & Accepted: Fence Masters, Inc. (Seller)

Approved & Accepted by Purchaser:  
Moss & Associates

By  \_\_\_\_\_  
**Signature**  
Carlo S. Cortina, Project Manager

By \_\_\_\_\_  
**Signature**  
\_\_\_\_\_



525 Distribution Drive  
Melbourne, FL 32904-1184  
(321) 728-2932  
Sales Fax: (321) 728-2933  
Sales Phone: (800) 290-7473

Remit Payment to:  
Stephens Pipe & Steel, LLC  
P.O. Box 618  
Russell Springs, KY 42642

Visit our website:  
<https://SPSfence.com>

QUOTATION #: 06-230294 Pg 1 of 1  
Billing Date : 4/13/2026  
Customer Acct: 30017  
Payment Terms: NET-60  
Customer PO #:  
Sales Person : P.OAKLEY  
Made By User : erikvassallo  
SPS Order # : 0-0  
Shipped Via : OT  
Contact Name : STEVE ERNST  
Cust Mobile : 3057960163 STEVE  
Fax number : 3056357887

**\* Quote valid 5 days. Expires: 4/18/2026 \***

Sh Note: CALL JOHN 305.796.0164 FOR DELV

Sold To: FENCE MASTERS @MIAMI  
3550 NW 54TH ST  
MIAMI, FL 33142-3250

Ship To: FENCE MASTERS @MIAMI  
(305) 635-7777  
3550 NW 54TH ST  
MIAMI, FL 33142-3250

**\*\* Send Invoice by EMAIL ONLY.**

**CUSTOMER MUST FIELD VERIFY ALL MATERIALS. SPS IS NOT RESPONSIBLE FOR FINAL QUANTITIES OR TAKEOFFS!**

Ordered	Shipped	BackOrder	Unit	Product Item Description	Price	Amount
600	600	0	ft	GRN VNL 2B 2x8(9core)x96in KT 50ft/rll ** VERIFY SELVAGE	7.8608	4,716.48
1827	1827	0	ft	GRN PLY 1-5/8" x 21' x PP40 x 87pc	2.3434	4,281.39
64	64	0	pc	GRN PLY 3" x 12' x PP40	70.363	4,503.20
11	11	0	ea	GRN PLY TENSION BAR 96"x3/4"	9.933	109.26
77	77	0	ea	GRN PLY TENSION BAND 3in	2.5036	192.78
33	33	0	ea	GRN PLY BRACE BAND 3in	2.8305	93.41
58	58	0	ea	GRN PLY PS LOOP CAP 3x1-5/8in	9.054	525.13
33	33	0	ea	GRN PLY PS RAIL END COMBO 1-5/8in	3.2924	108.65
6	6	0	ea	GRN PLY PS DOME CAP 3in	6.538	39.23
200	200	0	ea	BOLT/NUT 3/8x2-1/2in	0.254	50.80
1000	1000	0	ea	GRN VNL STEEL TIE 9gax6-1/2in	0.092	92.00
500	500	0	ea	GRN VNL STEEL TIE 9gax9-1/2in	0.143	71.50
116	116	0	set	GRN PLY BLVD CLAMP 3x1-5/8in	7.155	829.98

Ask me about ACCESS CONTROL.  
Call today and request to receive invoices via email.

	15,613.81
Fuel Charge	25.00
6.32% Tax	986.83
<b>Total Order</b>	<b>16,625.64</b>

+ Concrete

MATERIALS RECEIVED BY: \_\_\_\_\_ PRINT Name: \_\_\_\_\_ DATE: \_\_\_\_/\_\_\_\_/\_\_\_\_

Acceptance of quote confirms your approval of materials as quoted.  
Review all items. Any discrepancies MUST BE noted on original delivery document and VERIFIED BY DRIVER. Buyer agrees to pay all applicable taxes. Invoices not paid within terms will be charged a 1.6% monthly service charge. If payment made with credit card, a 3% convenience fee will be added. PRICES MAY CHANGE WITHOUT NOTICE! Returns subject to 15-50% Restock Fee.

LRS:10, BBE P/D:04-14  
CAM:26-0510



# TYMETAL

SECURITY GATES & PERIMETER SOLUTIONS

678 Wilbur Avenue, Greenwich, New York 12834  
 P:800.328.4283 F:518.692.9404 [www.tymetal.com](http://www.tymetal.com)

# QUOTATION

**Quote #** TYMQ173359  
**Date** 10/28/25  
**Sales Rep.** RRabine

**Quote To:**

**Carlo Cortina**  
 Fence Masters, Inc. - FL  
 3550 NW 54th St.  
 Miami, FL 33142  
 Phone: (305)300-8110

**Ship To:**

Ft Lauderdale PD 24x8 ORN STR HYD F

**Project Name:**

Ft Lauderdale PD 24x8 ORN STR HYD FL

Thank you for your inquiry regarding the above project, please find our quotation below.

Customer is responsible for compliance with plans and specifications for product type, material, size and quantity. If any of our quantities vary from yours, contact us and we will re-quote as needed.

Note: For sites with higher operational, non-typical, or specified wind loadings Tymetal should be advised of the site conditions and a specifically engineered design will be offered.

PRICING IS SUBJECT TO CHANGE DUE TO TARIFFS, TAXES, AND OTHER FEES.

Qty	Description	Opening Width	Gate Height	Unit Price	Ext. Price
1	Ornamental Structural Cantilever Slide Gate w/ HYD Operator			\$32,480.00	\$32,480.00
	Fortress Structural Cantilever Slide Gate (OAL = 36' 0")	24' 0"	8' 0"		
Gate to be fabricated in one piece.					
1"x1" square aluminum pickets spaced approximately 3"o.c. Pickets will run through the opening portion of the gate only.					
Note: Black, plastic mesh will be provided (to be installed by the customer) when the picket spacing allows for an opening greater than 2 1/4". The installation of a secondary filler is required per ASTM F2200 when a motorized gate operator is to be applied to the gate.					
Curved, Smashed Point Pickets - Pickets extend above the top primary, but not below the bottom primary. A sample of the curved picket is required prior to fabrication if a match is to be made to a specific curve.					
NOTE: Candy Cane or Shepherd's Hook style pickets are also available but not included in this quote. Contact Tymetal for pricing.					
Gate to be powder coated stock, standard black. Non-stock, non-standard color coating will require an upcharge.					
	Cantilever Slide Gate Hardware for 4" <del>O.D.</del> Posts		6 5/8" OD		

Qty	Description	Opening Width	Gate Height	Unit Price	Ext. Price
	Support posts by others. Five (5) posts are required for this gate.				
	<p>TYM-HYD VF2/3 Hydraulic Slide Gate Operator - 2hp with heater, UL 325 6th edition compliant. 2.2 ft/sec. or 3 ft/sec. Max. gate weight = 5000#. Choose: (208 or 230v, 1ph; 208, 230 or 460v, 3ph; 60 Hz). Smart Touch 725 Controller with Bluetooth Smartphone Interface and Soft stop/soft start using Integrated variable frequency drive. Solid state dual limit sensors &amp; drive rail mounted limit flags. (5) configurable relays. Includes 8" AdvancedDrive with 4.0 GPM pump pack. Outside cover is heavy 10 gauge galvanized steel with mogul lock (3 keys per key code included. Both cover and chassis are zinc plated steel with custom color powder coat gray (RAL 7038)..</p> <p>NOTE- External reset button not available on cover. Optional Loop modules sold separately.</p> <p>ELECTRICAL NOTE: Variable Frequency Motor Controllers requires proper grounding and clean power. Some installations have required additional transformers to regulate voltage within +/- 10% and have required transient voltage devices to condition supply power. These issues and devices are not part of Tymetal's scope.</p>				
	(3) Mogul Key for commercial motorbox lock TYC800A - 3 keys per code at no charge.				
	<p>Portable ground rod kit for gate operators and lane access control pedestals. Includes 8' ground rod, ground rod clamp, and 6 ft of 6 gauge copper cable.</p>				
	(2) HY 5B Loop Detector (uninstalled) -(replaces 25280) HyS plug in model requires only loop wire by others and attachment				
	<p>(2) Photoeye Kit with Shield Cone [70' &amp; less] - (1) Set of Independent Transmitter/Receiver &amp; Hoods with (2) mounting plates and mounting hardware. 10-24vac/ vdc with 115' range. Plates mount to separate 2" OD pipe to prevent vibration, appx 26" above grade. 2" OD support post pipe is supplied and installed by others. Includes 10K EOL Jumper feature for Post 2016 monitoring (not needed for VS models) and Manufactures operating Instructions.</p> <p>INCLUDES: Tymetal Installation Manual (#24793)</p> <p>NOTE: A minimum of 2 kits are typically required as entrapment protection with a Tymetal Operator. Installer is responsible to ID all entrapment zones and install appropriate protective devices per UL 325 requirements. Both transmitter and receiver require conduits for wiring. AFA mounting instruction included.</p> <p>TECHNICAL: NEMA 4X 10-24vac/dc; 37ma total draw TX; 23ma total draw standby; 17ma detecting @ 24v. Emitter alone: 5mA draw. Contacts for 5a @30vdc/250vac. -40 to 170 degree F (Uses MON EMX IRB Only) replaces 45054</p>				
	Hardware Kit -Drive Rail Mount - ( Hyd Drive Rail Mtg Kit includes 2" Square Stainless U bolts, 1/4 locknuts and spacer for 2" uprights, angles and drive rivets to terminate drive rail, and rollpins to connect rail. MUST				

Qty	Description	Opening Width	Gate Height	Unit Price	Ext. Price
	ref gate model and length for proper kit parts.)				
(3)	Drive Rail -traction blast-TYM 20'				
	Snow Brushes and Scrapers kit with mounting hardware- for 50VF2/3 cabinet that is predrilled, material must be field-attached. CAUTION:bristles may need trimming to avoid ramp-down switch interference				
	Strobe/Alarm combination, ADA compliant 24vdc 170mA [may require bridge rectifier #36352 - with 24vac input only) . Apex2 DC output is 750 mA				
* (3)	Hardware Kit -Drive Rail Mount - (Hyd Drive Rail Mtg Kit for Box Frame Roller includes fasteners for attaching hyd drive rail to gate mounting surface and plate for offsetting operator. Field drilling is required.)				
* (4)	Base Extension (12" riser, pedestal) fits under TYM-HYD slide gate operator ( 50VF2/3 ) painted matching Tymetal Custom Gray - customer installs on operator. 4 to 8 week lead time.				
	Dedicated trucking - the truck can be arranged per your project requirements, including the day and time of delivery.				

SubTotal	\$32,480.00
+ Freight ESTIMATE	\$3,603.00
Sales Tax to be added unless Tymetal is provided with a tax exempt or resale certificate	
<b>Total</b>	<b>\$36,083.00</b>

Freight ESTIMATE is subject to prevailing market rates at the time of order placement.

Standard Lead-times: Swing Gates 4-6 weeks, Non-crash Gates 5-7 weeks, Ornamental gates 7-9 weeks, BFR Gates 12-14 weeks, 2150 Ped Gates 10-12 weeks, VPG 14-16 weeks, Crash Gates 12-14 weeks from receipt of all required documents. Add 2-3 weeks for powder coated gates. Expedited lead time may be available at an additional charge. Actual lead time to be determined upon placement of order.

Terms & Conditions: Please see TYMETAL CORP. - TERMS AND CONDITIONS.

Billing: If customer delays shipment of completed product, TYMETAL reserves the right to transfer ownership of the material to customer upon completion. If customer is not ready to receive completed product, then TYMETAL will store on premises for customer. Upon ownership transfer, TYMETAL will bill customer for product and payment will be required per terms and conditions of sale.

Payment: PREPAYMENT with PO unless existing TYMETAL Approved Credit Account, then Net 30 Days subject to Credit Limit Amount.

Currency: US Dollar.

This quotation is valid for 30 days from above date.

WARRANTY: The addition of any items or material (signs or decorations over 2 sq. ft., privacy slats, etc.) that adds weight or wind loading to the gate system may void your warranty. Tymetal is not responsible for damage to the gates as a result of excessive wind and weight loading. For In-fills installed by the end user over 1#/sq.ft. or with less than 75% open area consult Tymetal Engineering for suitability.

Kind regards,

RRabine  
rrabine@tymetal.com

Accepted By: *[Signature]*  
Title: *Pres*  
Date: \_\_\_\_\_  
PO #: \_\_\_\_\_

Quote # and total \$ value (PO Total): TYMQ173359 \$36,083.00

*+ TAX*



RFI#  
**Project Name:** FLPD  
**Project Number:** 23-414  
**Page Number:** 1  
**Change Order #:** 84R1  
**Change Order Date:** 5/4/2026

**Moss**  
 2101 N ANDREWS AVE  
 FT LAUDERDALE, FL 33311  
 Telephone: (954) 524-5678

---

**Scope of work**

---

At the request of ownership, this change order proposal is for the labor and material associated with the addition of a security gate to the Sally Port exit on the east side of the Headquarters building.

This proposal includes the following scope:

- Removal of existing handholes.
- Excavation, trenching, and backfill utilizing a mini excavator and operator.
- Installation of underground conduit and handhole provisions for both power and low voltage systems.
- Conduit connections to the security gate's controller for power and low voltage.
- Installation of jetline and power conductors pulling for associated raceways.
- Installation of low voltage raceways with jetline.
- Installation of safety switch disconnect for power to security gate's controller.
- Removal of three (3) spare 20A 1 pole existing breakers from electrical panel L1A-1 circuits #25,27,29.
- Furnishing and installation of new one (1) 20A 3 Phase breaker to electrical panel L1A-1 circuits #25,27,29.
- Termination of homerun conductors to breaker.
- Coordination and commissioning support of the security gate with gate subcontractor.

This proposal excludes the following:

- Surveying and layout of security gate equipment, associated sensors and pedestals.
- Removal and replacement of access ceiling tiles.
- Demolition, relocation, protection, or removal of existing or completed millwork.
- Relocation, protection, or removal of furniture.
- Repair, coring, patching, and/or painting of finishing surfaces impacted by this work.
- Concrete coring, drilling, cutting and/or backfilling.
- Any low voltage cabling, terminations, repairs and/or troubleshooting to be done by low voltage sub.
- Specialty or custom materials not specifically identified in this proposal.
- Waterproofing of any kind.
- Accelerated schedule requirements.
- After hours and/or overtime hours.
- Permit fees.
- Clean up.

**All remedial or repair work necessary due to these changes is to be performed by others. Any unforeseen conditions, code requirements, or field conflicts discovered after work begins that impact labor or material shall be addressed via additional cost and time adjustment.**

---

**Summary**

---

**MATERIAL**

General Materials		2,938.84
Switchgear		978.42
Material Tax	(@ 7.000 %)	274.21

<b>Material Total</b>	<b>4,191.47</b>
-----------------------	-----------------

Phone: 305-669-1776 Fax: 305-669-1710



**Moss**  
 2101 N ANDREWS AVE  
 FT LAUDERDALE, FL 33311  
 Telephone: (954) 524-5678

**RFI#**  
**Project Name:** FLPD  
**Project Number:** 23-414  
**Page Number:** 2  
**Change Order #:** 84R1  
**Change Order Date:** 5/4/2026

---

**Summary (Cont'd)**

---

**LABOR**

ELECTRICIAN	(83.39 Hrs @ \$55.00)	4,586.45
FOREMAN	(20.22 Hrs @ \$65.00)	1,314.30
SUPERINTENDENT	(8.12 Hrs @ \$70.00)	568.40
PROJECT MANAGER	(2.55 Hrs @ \$85.00)	216.75
BIM COORDINATION	(2.37 Hrs @ \$55.00)	130.35
CLEAN UP	(8.00 Hrs @ \$52.00)	416.00
ESTIMATING	(5.00 Hrs @ \$55.00)	275.00
AS-BUILT DRAWINGS	(2.00 Hrs @ \$55.00)	110.00

<b>Total Labor</b>		<b>7,617.25</b>
--------------------	--	-----------------

**EQUIPMENT**

9,500 LB MINI EXCAVATOR W/ CAB & 24" BUCKET		4,246.83
---	--	----------

<b>Total Equipment</b>		<b>4,246.83</b>
------------------------	--	-----------------

<b>TOTAL MATERIAL, LABOR &amp; EQUIPMENT</b>		<b>16,055.55</b>
--	--	------------------

OH&P	(@ 10.000 %)	1,605.56
------	--------------	----------

<b>Final Amount</b>		<b>\$17,661.11</b>
---------------------	--	--------------------



**Moss**  
 2101 N ANDREWS AVE  
 FT LAUDERDALE, FL 33311  
 Telephone: (954) 524-5678

**Project Name:** FLPD  
**Project Number:** 23-414  
**Page Number:** 3  
**Change Order #:** 84R1  
**Change Order Date:** 5/4/2026

**Itemized Breakdown**

**HQ-E1-1-00**

Description	Qty	Net Price U	Total Mat.	Labor U	Total Hrs.
30A 3P 480V NEMA 3R DISCONNECT	1	432.00 E	432.00	1.38 E	1.38
FIBERGLASS HANDHOLE 18" X 24"	2	550.00 E	1,100.00	7.50 E	15.00
EXCAVATION (CUBIC YARD)	7	0.00 E	0.00	0.30 E	2.10
BACKFILL (CUBIC YARD)	7	0.00 E	0.00	0.30 E	2.10
COMPACTION (LINEAR FOOT)	207	0.00 E	0.00	0.02 E	4.14
1" DIAM CORE 6" THICK WALL	1	75.00 E	75.00	0.00 E	0.00
FIRESTOP COMPOUND CAULK (1) PIPE	4	1.00 E	4.00	0.06 E	0.24
3/4" CONDUIT - EMT	70	154.78 C	108.35	4.40 C	3.08
3/4" COUPLING COMP STL - EMT	6	424.55 C	25.47	37.50 C	2.25
3/4" CONN COMP STL INSUL - EMT	4	471.66 C	18.87	15.63 C	0.63
3/4" LOCKNUT - STEEL	18	51.00 C	9.18	2.88 C	0.52
3/4" BUSHING GRDG INSUL - STEEL	4	379.94 C	15.20	3.50 C	0.14
3/4" 1-H STRAP - EMT - STEEL	4	51.58 C	2.06	6.75 C	0.27
1/2 OR 3/4" CONDUIT SNAP CLOSE CLIP W/ 1/4-20 THRD	9	52.18 C	4.70	7.13 C	0.64
3/4" FLEX - STEEL	10	212.00 C	21.20	4.88 C	0.49
3/4" CONN FLEX DC SQUEEZE STRAIGHT	1	216.63 C	2.17	12.50 C	0.13
3/4" CONN FLEX DC SQUEEZE 90 DEG	1	446.91 C	4.47	12.50 C	0.13
3/4" FLEX - LIQUIDTIGHT METALLIC - GRAY	11	417.00 C	45.87	6.19 C	0.68
3/4" FLEX - LIQUIDTIGHT METALLIC - EXTRA FLEX	10	0.00 C	0.00	6.19 C	0.62
3/4" CONN STRAIGHT - LIQUIDTIGHT DIECAST	1	652.54 C	6.53	21.25 C	0.21
3/4" CONN 90 DEG - LIQUIDTIGHT DIECAST	1	1,187.58 C	11.88	21.25 C	0.21
3/4" CONN STRAIGHT INSUL - LIQUIDTIGHT DIECAST	1	728.22 C	7.28	21.25 C	0.21
3/4" CONN 90 DEG INSUL - LIQUIDTIGHT DIECAST	1	1,383.90 C	13.84	21.25 C	0.21
3/4" CONDUIT - PVC40	210	44.33 C	93.09	4.50 C	9.45
3/4" ELBOW 90 DEG - PVC40	18	156.60 C	28.19	23.75 C	4.28
3/4" COUPLING - PVC	36	42.40 C	15.26	0.00 C	0.00
3/4" ADAPTER MALE - PVC	18	73.90 C	13.30	12.50 C	2.25
3/4" END BELL - PVC	2	686.56 C	13.73	6.25 C	0.13
4x 1 1/2" SQ BOX COMB KO	1	1,469.00 C	14.69	28.75 C	0.29
4" SQ 1x TOGGLE SWITCH COVER	1	1,148.97 C	11.49	3.13 C	0.03
GROUND SCREW W/ INSUL #12 LEAD	1	503.57 C	5.04	3.75 C	0.04
1 5/8x 1 5/8x 14G STRUT GALV	4	450.87 C	18.03	12.50 C	0.50
1/4-20x 1 5/8x 13/16 SPRING NUT	4	266.83 C	10.67	5.00 C	0.20
1/4-20 MACHINE SCREW ANCHOR	13	29.24 C	3.80	10.00 C	1.30



**Moss**  
 2101 N ANDREWS AVE  
 FT LAUDERDALE, FL 33311  
 Telephone: (954) 524-5678

**Project Name:** FLPD  
**Project Number:** 23-414  
**Page Number:** 4  
**Change Order #:** 84R1  
**Change Order Date:** 5/4/2026

Description	Qty	Net Price U	Total Mat.	Labor U	Total Hrs.
1/4" THREADED ROD - PLTD	27	68.72 C	18.55	3.13 C	0.85
1/4-20 HEX NUT - PLTD STL	9	3.14 C	0.28	2.50 C	0.23
1/4x 1 1/4 FENDER WASHER - PLTD STL	8	7.42 C	0.59	1.25 C	0.10
1/4-20x 1 1/4 P/H SLOT/PHILLIPS MACHINE SCREW	8	6.42 C	0.51	4.50 C	0.36
#8x 3/4 P/H SELF-TAP SCREW	4	10.08 C	0.40	3.25 C	0.13
3/16x 1 1/4 CONCRETE SCREW HEX HEAD - BLUE	18	45.53 C	8.20	8.50 C	1.53
1/4x 1 3/4 CONCRETE SCREW HEX HEAD - BLUE	1	69.08 C	0.69	10.75 C	0.11
#12 THHN BLACK	269	257.16 M	69.18	6.44 M	1.73
#10 THHN BLACK	1,406	393.32 M	553.01	7.06 M	9.93
#10 THHN GREEN	364	393.32 M	143.17	7.06 M	2.57
WIRE CONN RED	8	19.64 C	1.57	4.00 C	0.32
1/8" POLYTWINE	614	11.94 M	7.33	3.75 M	2.30
EQUIPMENT HOOKUP	2	0.00 E	0.00	1.00 E	2.00
<b>Totals</b>	<b>3,427</b>		<b>2,938.84</b>		<b>75.98</b>

**HQ-E5-1-10**

Description	Qty	Net Price U	Total Mat.	Labor U	Total Hrs.
REMOVAL OF (3) 1P SPARE BREAKERS	1	0.00 E	0.00	0.50 E	0.50
INSTALLATION OF 3P BREAKER	1	0.00 E	0.00	0.50 E	0.50
DEENERGIZING OF CIRCUIT BREAKER	1	0.00 E	0.00	1.00 E	1.00
ENERGIZING OF CIRCUIT BREAKER	1	0.00 E	0.00	1.00 E	1.00
<b>Totals</b>	<b>4</b>		<b>0.00</b>		<b>3.00</b>

**CLIENT ACCEPTANCE**

<b>Name:</b>	_____
<b>Date:</b>	_____
<b>Signature:</b>	_____
I hereby accept this quotation and authorize the contractor to complete the above described work.	

**Brandon Rodriguez**

**From:** Hung, Adrian <adrian.hung@anixter.com>  
**Sent:** Friday, April 3, 2026 11:30 AM  
**To:** Hung, Adrian  
**Subject:** Bid SE45586399

**Quotation**

**#3863 MIAMI APS  
ANIXTER INC.  
11420 NORTHWEST 122ND ST  
SUITE 100  
MEDLEY FL 33178  
305-805-3830 Fax 305-805-3869**

SE45586399  
11:30:03EST 04/03/26

All sales are subject to Anixter Inc.'s Terms & Conditions of Sale found at [https://www.anixter.com/en\\_us/resources/terms-of-sale.html](https://www.anixter.com/en_us/resources/terms-of-sale.html) PRODUCT SAFETY DATA SHEETS ON SAME WEB SITE.

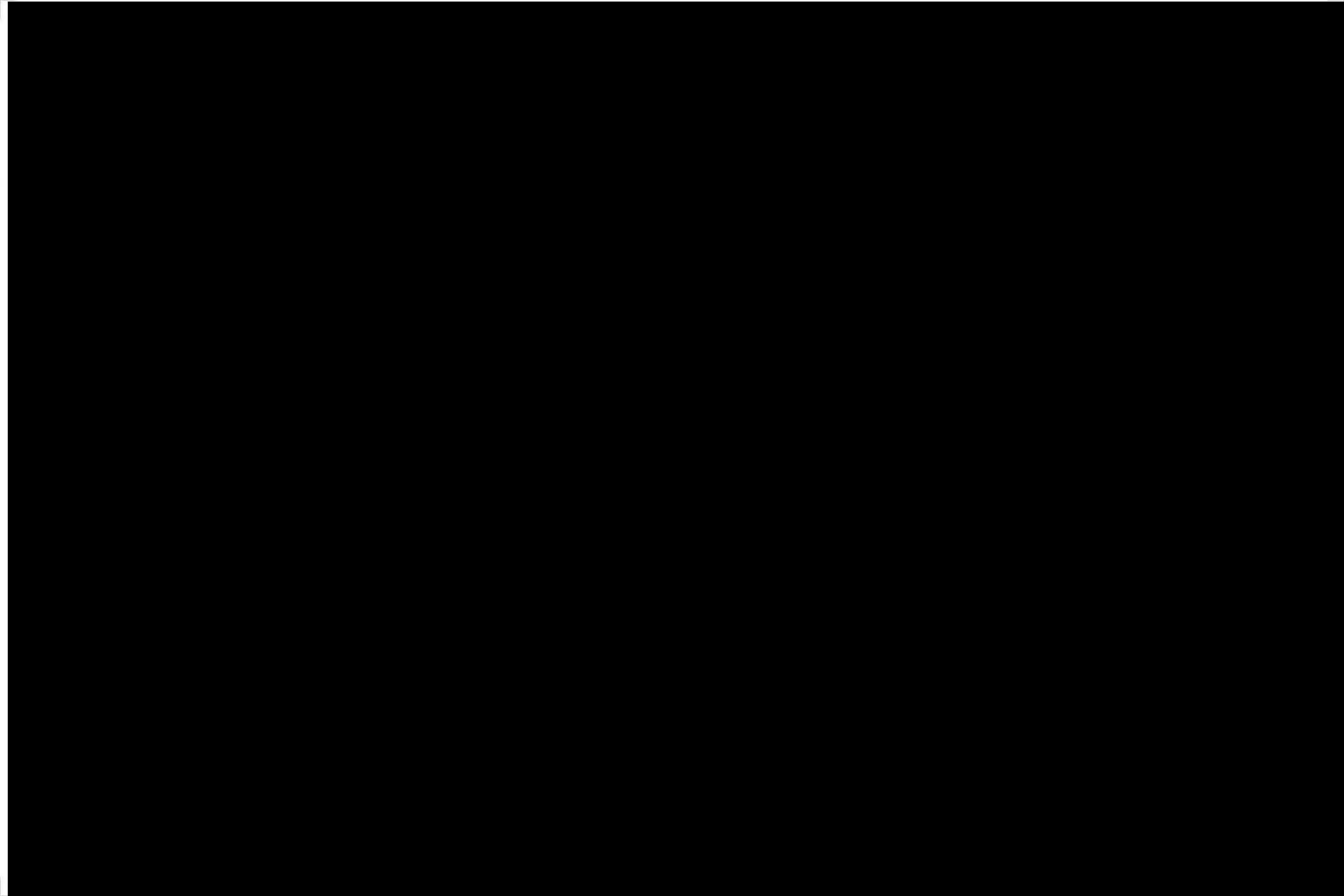
**Sold To:48923**  
THUNDER ELECTRICAL CONTRACTORS  
INC  
7035 F SW 47TH STREET STE F  
MIAMI, FL 33155  
305-669-1776 Fax 305-669-1710

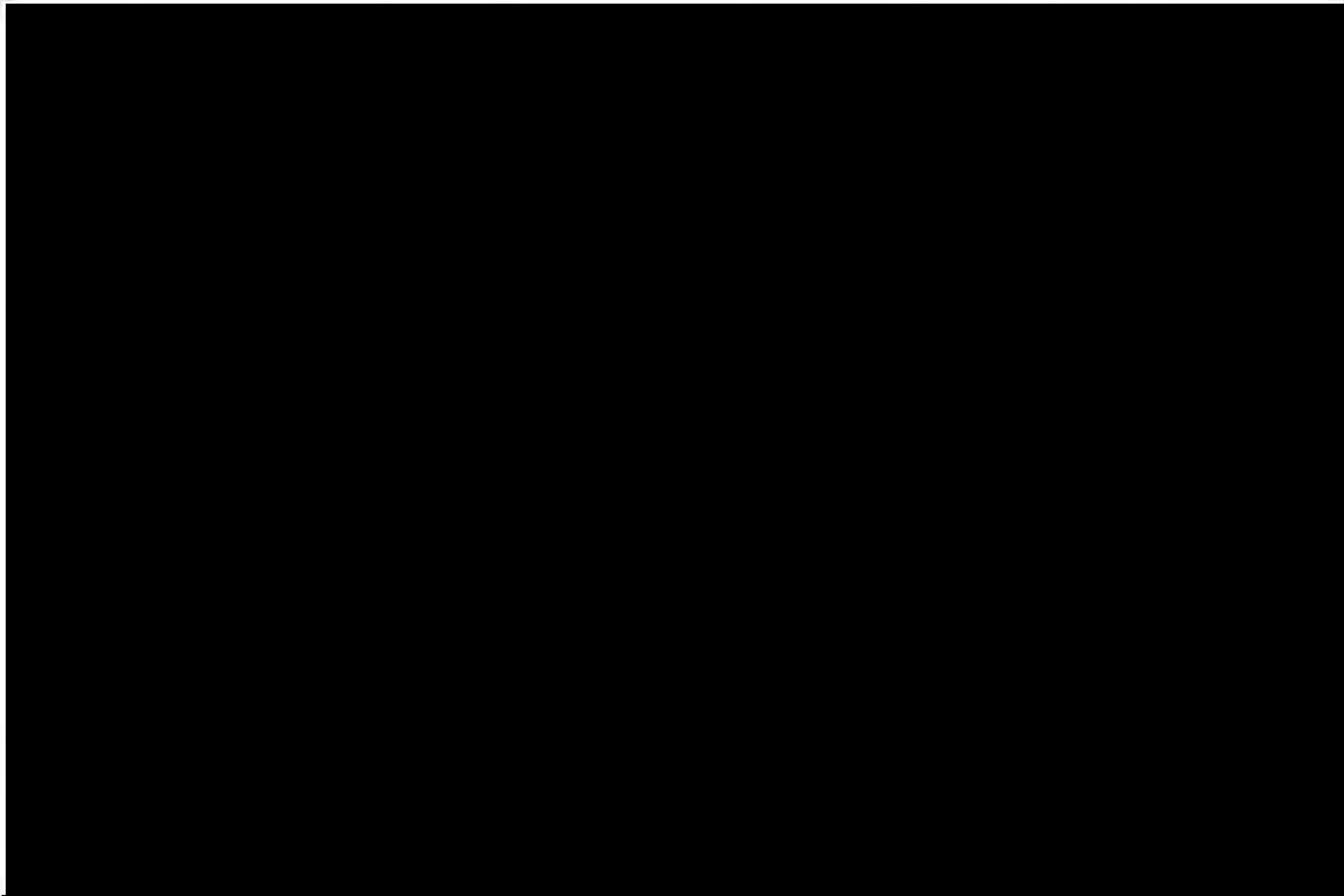
**Ship To:1168251**  
FT LAUDERALE POLICE HQ  
1300 W BROWARD BLVD  
FORT LAUDERDALE, FL 33312-1699  
305-669-1776 Fax 305-669-1710

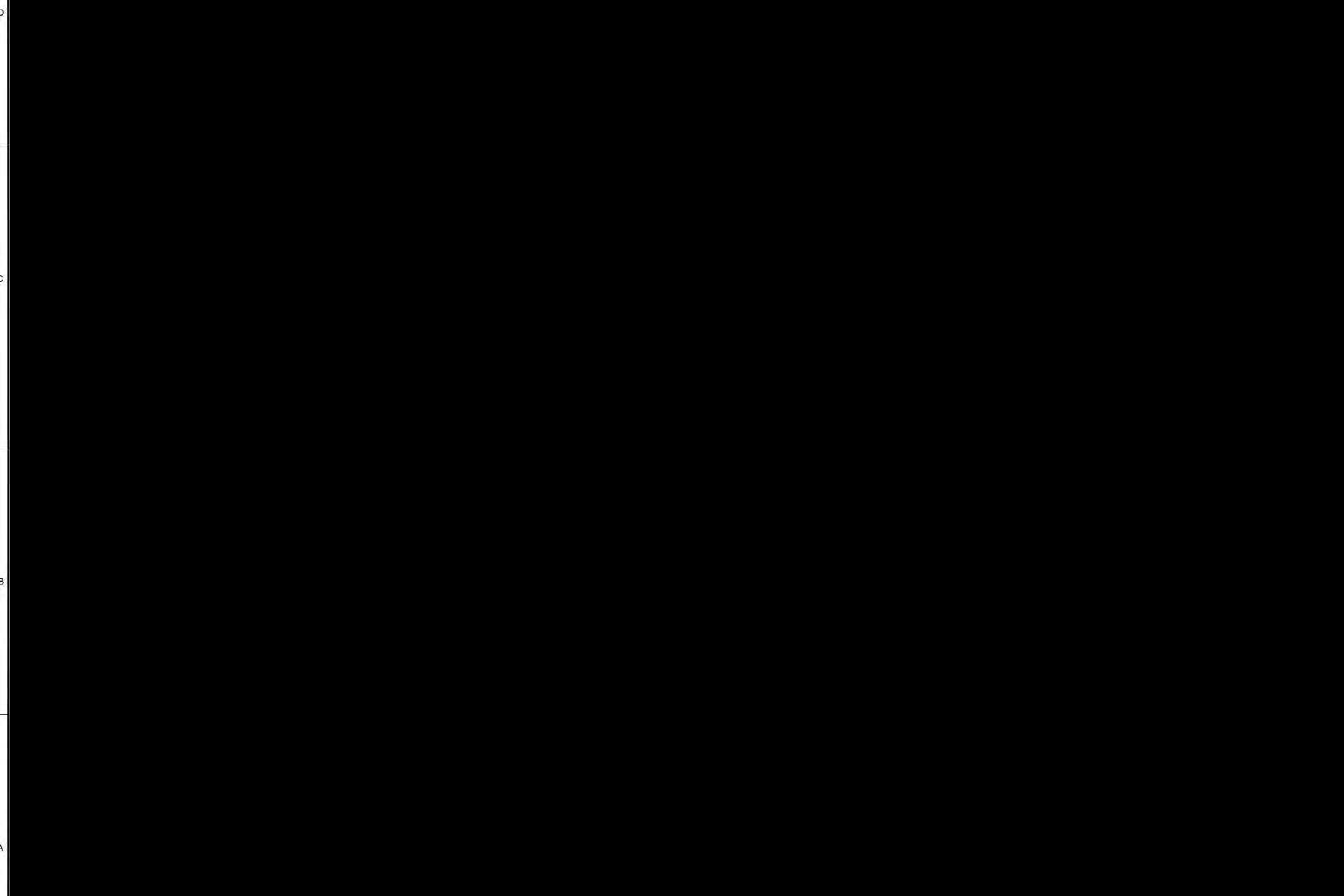
Ordered By	Ship Via	Quote Date			
.		04/03/26			
Writer	Freight Terms/FOB	Expiration Date			
Adrian Hung	No	04/13/26			
Salesperson	Terms	FOB			
Adrian Hung	NET 10TH PROX 1.5% SC 25				
Special Instructions					
Quantity	Product Description	FD	Unit Price	UM	Net Amount
1ea	C-H DG321UGB 30A/3P GD SFTY SW 240V		60.891	ea	60.89
1ea	C-H BAB3020H 20A 3P CKT BRKR		171.522	ea	171.52
1ea	QZT PG1730BA12 BOX ONLY STK BX STD OPN BASE		278.016	ea	278.02
1ea	QZT PG1730HH0017 17X30 COVER - HEAVY DUTY TIER 22		403.976	ea	403.98
Wesco may assess storage and transportation fees if you do not take or accept delivery within 90 days of product availability. Wesco may also update this quote or above pricing due to duties, freight, tariffs, supplier					

pricing, surcharges, or exchange rate fluctuations. BY  
 ACCEPTING THIS QUOTE, YOU AGREE THAT THE TERMS  
 AND CONDITIONS OF SALE PUBLISHED AT  
[www.wesco.com/termsofsale](http://www.wesco.com/termsofsale) ARE EXPRESSLY  
 INCORPORATED INTO AND SHALL GOVERN THIS  
 TRANSACTION.

Total Weight 72.5 lbs	<b>Subtotal</b>	914.41
THIS IS A QUOTATION	S&H	0.00
Prices are firm until 04/13/26, subject to change without notice after 04/13/26.	<b>Tax</b>	<b>64.01</b>
SALES TAX IS AN ESTIMATE!S&H IS AN ESTIMATE!	<b>Total</b>	<b>978.42</b>









**Moss & Associates, LLC**  
 6363 NW 6th Way  
 Ft Lauderdale, FL 33309

May 18, 2026

Ronald Stein  
 City of Fort Lauderdale  
 101 NE 3rd Ave, Suite 2100  
 Ft. Lauderdale, FL 33301

RE: Potential Change Item (PCI) CON0080 Notification  
 Fort Lauderdale Police Headquarters - B372302

Dear Ronald Stein,

This letter is to provide official notification of a potential change item (PCI) as follows:

PCI Number: CON0080  
 Date: May 18, 2026  
 Description: Cooler to Freezer Swap  
 Days Requested:  
 Reason: Contingency - External  
 Scope Description:

This PCI is comprised of the following items.

Cooler to Freezer Swap	\$ 24,740.54
Construction Manager's Contingency	\$ -24,740.54
<b>Grand Total</b>	<b>\$0.00</b>

Per the terms and conditions of our contract, we have attached the appropriate back up documentation to substantiate the above referenced costs. This request only includes the items specifically identified in this change proposal. All other costs associated with this project shall be submitted under a separate change order cover.

The costs associated with this PCI will remain valid for fourteen (14) calendar days after submission.

Please indicate your formal approval for this additional work and cost by signing in the space provided below. Moss & Associates will then incorporate this change into the next Owner Change Order (OCO).

If you should have any questions, please contact the undersigned at 954-326-2727 as soon as possible.

<p>Sincerely,  <b>Moss &amp; Associates, LLC</b></p> <p style="text-align: right;">Date: _____</p> <p>Matthew Kane          Sr. Project Manager</p>	<p>Reviewed / Approved by:  <b>City of Fort Lauderdale</b></p> <p><b>Approved:</b> _____ <b>Date:</b> _____          (Owner)</p>
---	--



# Quote

05/17/2026

**To:**  
 Hyvac  
 Jose Rodriguez  
 305-505-3151 (Cell)

**Project:**  
 Ft Lauderdale Police Headquarters -  
 Evidence Cooler conversion to Freezer

**From:**  
 Lace Foodservice  
 Luis Fernandez  
 10490 NW 26 Street  
 Miami, FL 33172  
 305-513-5223  
 305-513-5223 (Contact)  
 305-525-3823 (Cell)  
 305-513-5229 (Fax)  
 Luis@LaceFoodservice.com

Item	Qty	Description	Sell	Sell Total
1	1 ea	<b>COOLER TO FREEZER CONVERSION</b> Kolpak Convert Evidence cooler to a freezer - scope of work: 1- pump down system, recover freon, and take to refrigerant recycle center 2- remove existing refrigeration line set 3- install new refrigeration line-set from remote condenser to evaporator 1- pump down and recover Freon 2- remove complete existing refrigeration line set 3- install new refrigeration line-set from remote condenser to evaporator (existing suction line is 5/8" and 1-1/8" is needed for new freezer unit) 4- remove existing evaporator fan unit and replace with new freezer evaporator 5- remove existing remote condensing unit and replace with new freezer condensing unit 6- add defrost timer 7- remove existing cooler door heater and replace with freezer high wattage door perimeter heater 8- remove existing door window and replace with high wattage window/heater 9- remove existing condensate drain heater/insulation and replace with higher wattage freezer heater/insulation 9- charge new system and startup/commission  NOT INCLUDED: 1- electrical work 2- plumbing work 3- mechanical lift if required to reach refrigeration lines	\$14,679.00	\$14,679.00

Merchandise	\$14,679.00
Freight	\$643.00
Installation	\$7,800.00
Tax 7%	\$1,618.54
<b>Total</b>	<b>\$24,740.54</b>

[Redacted main body text]





**Moss & Associates, LLC**  
 6363 NW 6th Way  
 Ft Lauderdale, FL 33309

April 10, 2026

Ronald Stein  
 City of Fort Lauderdale  
 101 NE 3rd Ave, Suite 2100  
 Ft. Lauderdale, FL 33301

RE: Potential Change Item (PCI) 0387 Notification  
 Fort Lauderdale Police Headquarters - B372302

Dear Ronald Stein,

This letter is to provide official notification of a potential change item (PCI) as follows:

PCI Number: 0387  
 Date: April 10, 2026  
 Description: DAS Firstnet Amplifier  
 Days Requested:  
 Reason: Owner Directive - External  
 Scope Description: At the request of ownership, this Change Order Proposal includes the labor and materials required to install a FirstNet (Band 14) cellular signal booster system to improve emergency responder coverage within the Headquarters and Parking Garage.

Per the attached Skylight Techs proposal, this scope includes furnishing and installation of four (4) WilsonPro 140i FirstNet signal booster units, with two (2) units in the Headquarters and two (2) units in the Parking Garage.

This PCI is comprised of the following items:

DAS Firstnet Amplifier	\$ 35,871.33
01 Subcontract Default Insurance 1.25%	\$ 448.39
02 Moss Insurance 1.75%	\$ 627.75
03 Bond 1%	\$ 358.71
04 Fee 4%	\$ 1,434.85
<b>Grand Total</b>	<b>\$38,741.03</b>

Per the terms and conditions of our contract, we have attached the appropriate back up documentation to substantiate the above referenced costs. This request only includes the items specifically identified in this change proposal. All other costs associated with this project shall be submitted under a separate change order cover.

We respectfully reserve our rights to request additional time should it become evident that this work will impact the overall completion of the project. The costs associated with this PCI will remain valid for fourteen (14) calendar days after submission.

Please indicate your formal approval for this additional work and cost by signing in the space provided below. Moss & Associates will then incorporate this change into the next Owner Change Order (OCO).

If you should have any questions, please contact the undersigned at 954-326-2727 as soon as possible.

<p>Sincerely,  <b>Moss &amp; Associates, LLC</b></p> <p>_____ Date: _____</p> <p>Matthew Kane          Project Manager</p>	<p>Reviewed / Approved by:  <b>City of Fort Lauderdale</b></p> <p><b>Approved:</b> _____ <b>Date:</b> _____          (Owner)</p>
--	--



RFI#  
**Project Name:** FLPD  
**Project Number:** 23-414  
**Page Number:** 1  
**Change Order #:** 85  
**Change Order Date:** 4/3/2026

**Moss**  
 2101 N ANDREWS AVE  
 FT LAUDERDALE, FL 33311  
 Telephone: (954) 524-5678

---

**Scope of work**

---

At the request of ownership, this Change Order Proposal includes the labor and materials required to install a FirstNet (Band 14) cellular signal booster system to improve emergency responder coverage within the Headquarters and Parking Garage.

Per the attached Skylight Techs proposal, this scope includes furnishing and installation of four (4) WilsonPro 140i FirstNet signal booster units, with two (2) units in the Headquarters and two (2) units in the Parking Garage.

Work includes equipment mounting, integration with the existing coaxial network, system setup, gain adjustment, RF optimization, and testing and commissioning to verify proper operation.

No additional work or provisions are required from Thunder, as integration of the Band 14 amplifiers into the existing cellular booster system via diplexers and splitters is inclusive in Skylight Techs' scope.

This proposal includes eight (8) hours of Thunder Project Manager time for participation in testing, signal readings, commissioning and turnover walkthroughs with Skylight Techs subcontractor and ownership.

**This proposal excludes the following:**

- Rough provisions.
- Power and/or lighting terminations.
- Equipment rentals
- Removal of access ceiling tiles.
- Demolition, relocation, protection, or removal of existing or completed millwork.
- Relocation, protection, or removal of furniture.
- Repair, patching, and/or painting of finished or any surfaces impacted by this work required to complete this work.
- Concrete coring, drilling, cutting and/or backfilling.
- Any low voltage cabling, terminations, repairs and/or troubleshooting to be done by low voltage sub.
- Specialty or custom materials outside of this proposal to be provided.
- Any waterproofing.
- Accelerated schedule requirements.
- After hours and/or overtime hours.
- Permit fees.
- Clean up.

**All remedial or repair work necessary due to these changes is to be performed by others. Any unforeseen conditions, code requirements, or field conflicts discovered after work begins that impact labor or material shall be addressed via additional cost and time adjustment.**

---

**Summary**

---

<b>MATERIAL</b>		
SKYLIGHT		29,790.00
Material Tax	(@ 7.000 %)	2,085.30
		31,875.30
<b>Material Total</b>		<b>31,875.30</b>

Phone: 305-669-1776 Fax: 305-669-1710



RFI#  
**Project Name:** FLPD  
**Project Number:** 23-414  
**Page Number:** 2  
**Change Order #:** 85  
**Change Order Date:** 4/3/2026

**Moss**  
 2101 N ANDREWS AVE  
 FT LAUDERDALE, FL 33311  
 Telephone: (954) 524-5678

---

**Summary (Cont'd)**

---

**LABOR**

PROJECT MANAGER	(8.00 Hrs @ \$85.00)	680.00
ESTIMATING	(1.00 Hrs @ \$55.00)	55.00
		735.00
<b>Total Labor</b>		<b>735.00</b>
 <b>TOTAL MATERIAL, LABOR &amp; EQUIPMENT</b>		<b>32,610.30</b>
OH&P	(@ 10.000 %)	3,261.03
<b>Final Amount</b>		<b>\$35,871.33</b>



**Moss**  
2101 N ANDREWS AVE  
FT LAUDERDALE, FL 33311  
Telephone: (954) 524-5678

**Project Name:** FLPD  
**Project Number:** 23-414  
**Page Number:** 3  
**Change Order #:** 85  
**Change Order Date:** 4/3/2026

---

**Itemized Breakdown**

---

---

**CLIENT ACCEPTANCE**

---

<p><b>Name:</b> _____</p> <p><b>Date:</b> _____</p> <p><b>Signature:</b> _____</p> <p>I hereby accept this quotation and authorize the contractor to complete the above described work.</p>
---

SKYLIGHT TECHNOLOGIES, INC. **Estimate 7877**  
 3281 NW 20 ST  
 MIAMI, FL 33142 USA  
 +13053632773  
 ellen@skytechslv.com



ADDRESS	SHIP TO	DATE	TOTAL
FORT LAUDERDALE POLICE HEADQUARTERS & PARKING GARAGE 7035-G SW 47 STREET MIAMI, FL 33155	FORT LAUDERDALE POLICE HEADQUARTERS & PARKING GARAGE 1300 W. BROWARD BLVD. FT. LAUDERDALE, FL 33312	03/30/2026	\$29,790.00

ACTIVITY	QTY	RATE	AMOUNT
FORT LAUDERDALE POLICE HEADQUARTERS & PARKING GARAGE - CELL BOOSTER FIRSNET BAND 14			
DOW Equipment: Supply of (4) WilsonPro 140i FirstNet (Band 14) signal booster. Materials: Cabling, connectors, mounting hardware, grounding, and miscellaneous RF components required for installation. Testing & Commissioning: Post-installation testing and verification of FirstNet (Band 14) signal in selected areas.	4	5,213.25	20,853.00
Note: This system is intended to enhance FirstNet signal only and is not a code-compliant public safety (ERRCS/BDA) system. Final performance depends on available donor signal and existing infrastructure.			
DOW Labor: Installation and integration of (4) WilsonPro 140i FirstNet (Band 14) signal booster into existing RF distribution system. Includes mounting, connection to existing coax network, system setup, gain adjustment, and RF optimization.	4	2,234.25	8,937.00

ESTIMATE IS GOOD FOR 30 DAYS.

**TOTAL \$29,790.00**

THANK YOU.

Accepted By

Accepted Date



**Moss & Associates, LLC**  
 6363 NW 6th Way  
 Ft Lauderdale, FL 33309

April 21, 2026

Ronald Stein  
 City of Fort Lauderdale  
 101 NE 3rd Ave, Suite 2100  
 Ft. Lauderdale, FL 33301

RE: Potential Change Item (PCI) 0388 Notification  
 Fort Lauderdale Police Headquarters - B372302

Dear Ronald Stein,

This letter is to provide official notification of a potential change item (PCI) as follows:

PCI Number: 0388  
 Date: April 10, 2026  
 Description: Additional Copper Backbone  
 Days Requested:  
 Reason: Owner Directive - External  
 Scope Description: South MPOE copper backbone per sketch dated 3.22.26. Revised per Sketch dated 4.14.26.  
 Reduce backbone in the building from 100 pair to 50 pair. Changed the cable to the elevator room to (1) CAT 6.

This PCI is comprised of the following items:

Additional Copper Backbone Revised per Sketch dated 4.14.26.	\$ 34,919.59
01 Subcontract Default Insurance 1.25%	\$ 436.49
02 Moss Insurance 1.75%	\$ 611.09
03 Bond 1%	\$ 349.20
04 Fee 4%	\$ 1,396.78
<b>Grand Total</b>	<b>\$37,713.15</b>

Per the terms and conditions of our contract, we have attached the appropriate back up documentation to substantiate the above referenced costs. This request only includes the items specifically identified in this change proposal. All other costs associated with this project shall be submitted under a separate change order cover.

We respectfully reserve our rights to request additional time should it become evident that this work will impact the overall completion of the project. The costs associated with this PCI will remain valid for fourteen (14) calendar days after submission.

Please indicate your formal approval for this additional work and cost by signing in the space provided below. Moss & Associates will then incorporate this change into the next Owner Change Order (OCO).

If you should have any questions, please contact the undersigned at 954-326-2727 as soon as possible.

Sincerely, <b>Moss &amp; Associates, LLC</b>  _____ Date: _____  Matthew Kane Project Manager	Reviewed / Approved by: <b>City of Fort Lauderdale</b>  <b>Approved:</b> _____ <b>Date:</b> _____ (Owner)
---	---

Date: **4/15/2026**

PROPOSAL NO: 210276 CO17 REV1	SUBMITTED TO: Matthew Kane
Moss & Associates LLC 2101 N. Andrews Ave. Ft. Lauderdale, Fl. 33311	<i>Job Location:</i> Ft. Lauderdale Police Dept. 1300 West Broward Blvd. Ft. Lauderdale, Fl. 33312
Phone Number: 321-427-3500	Email: mkane@moss.com

**MDF To MPOE South IDF 50 Pair Copper Backbone Cable****MPOE South IDF To PG 2<sup>nd</sup> FL North IDF 25 Pair Copper Backbone Cable****PG 2<sup>nd</sup> FL North IDF CAT6 Cable To Main Electrical Elevator Closet 1<sup>st</sup> FL.**

Quantity	Part #	Manufacture	Description	Material Cost	Unit	Totals	10% Overhead and Profit	Totals
140	Hourly Rate	Jade	Hourly Rate ST Time	\$88.430	HR	\$ 12,380.20		\$ 12,380.20
3000	51-478-48	Superior Essex	25 Pair Power Sum Category 5E	\$6.760	LF	\$ 20,280.00	\$2,028.00	\$ 22,308.00
3	41AB2-1F5	Leviton	CAT 5E 110 Style Wiring Block	\$35.500	EA	\$ 106.50	\$10.65	\$117.150
30	49105-IDC	Leviton	CAT 5E 119 Style C-5 Clips	\$0.880	EA	\$ 26.40	\$2.64	\$ 29.04
250	10136226	Berk-Tek	Cat6 Plenum Cable	\$0.260	EA	\$ 65.00	\$6.50	\$ 71.50
2	61110-RL6	Leviton	Cat6 Jacks Blue	\$5.250	EA	\$ 10.50	\$1.05	\$11.550
1	41089-1WP	Leviton	1 Port Surface Mount Box White	\$1.950	EA	\$ 1.95	\$0.20	\$ 2.145
								\$ 34,919.59

We hereby propose to furnish labor and materials-complete in accordance with the above specifications, for the sum of \$ **34,919.59**

***Balance due upon receipt of invoice.***

All material is guaranteed to be as specified. All work above to be completed in a skillful manner according to standard practices. Any alteration or deviation from above specifications involving extra cost will be executed only upon written orders, and will become a "T & M" extra charge over and above the estimate. All agreements are contingent upon strikes, accidents or delays beyond our control. No permit fees or bonding is included in this quotation. This proposal is subject to acceptance within thirty days and is void hereafter at the option of the undersigned. Florida License ES0000112. Pricing includes all sales tax.

**AUTHORIZED NAME**      **Serge Leblanc**      **4/15/2026**

**ACCEPTANCE OF PROPOSAL**

The above prices, specifications and conditions are hereby accepted. You are authorized to do the work as specified. Payment will be made as outlined above.

**ACCEPTED:**

Signature \_\_\_\_\_ Date \_\_\_\_\_

6610 E. ROGERS CIRCLE ° BOCA RATON, FLORIDA 33487 ° (561) 997-8552 ° FAX (561) 997-5935



**Moss & Associates, LLC**  
 6363 NW 6th Way  
 Ft Lauderdale, FL 33309

April 26, 2026

Ronald Stein  
 City of Fort Lauderdale  
 101 NE 3rd Ave, Suite 2100  
 Ft. Lauderdale, FL 33301

RE: Potential Change Item (PCI) 0389 Notification  
 Fort Lauderdale Police Headquarters - B372302

Dear Ronald Stein,

This letter is to provide official notification of a potential change item (PCI) as follows:

PCI Number: 0389  
 Date: April 26, 2026  
 Description: Evidence Locker Changes  
 Days Requested:  
 Reason: Owner Directive - External  
 Scope Description: Revised forensic lab evidence lockers per PD request.

This PCI is comprised of the following items:

Evidence Locker Changes per quote 7478	\$ 65,550.00
01 Subcontract Default Insurance 1.25%	\$ 819.38
02 Moss Insurance 1.75%	\$ 1,147.13
03 Bond 1%	\$ 655.50
04 Fee 4%	\$ 2,622.00

<b>Grand Total</b>	<b>\$70,794.01</b>
--------------------	--------------------

Per the terms and conditions of our contract, we have attached the appropriate back up documentation to substantiate the above referenced costs. This request only includes the items specifically identified in this change proposal. All other costs associated with this project shall be submitted under a separate change order cover.

We respectfully reserve our rights to request additional time should it become evident that this work will impact the overall completion of the project. The costs associated with this PCI will remain valid for fourteen (14) calendar days after submission.

Please indicate your formal approval for this additional work and cost by signing in the space provided below. Moss & Associates will then incorporate this change into the next Owner Change Order (OCO).

If you should have any questions, please contact the undersigned at 954-326-2727 as soon as possible.

<p>Sincerely,  <b>Moss &amp; Associates, LLC</b></p> <p>_____ Date: _____</p> <p>Matthew Kane          Sr. Project Manager</p>	<p>Reviewed / Approved by:  <b>City of Fort Lauderdale</b></p> <p><b>Approved:</b> _____ <b>Date:</b> _____          (Owner)</p>
--	--

# WORKSPACE TECHNOLOGY

## QUOTATION 7478

**PREPARED FOR**

**Moss**

**Ft. Lauderdale Police Department- RM 1409 Evidence Lockers**



**March 24, 2026**

**Registered Quotation # 7478**

Prepared by:

Bill Powers

**Workspace Technology, Inc.**

This is a confidential document between Moss and Workspace Technology, Inc. and may not be distributed to any person or company other than Moss personnel.

March 24, 2026

Matthew Kane  
Project Manager

**Subject: Quotation # 7478, Ft. Lauderdale Police Department- RM 1409 Evidence Lockers**

Dear Matthew:

The program, system and products detailed in the enclosed proposal have been tailored to the unique needs of Moss. As described, the proposal is available for your acceptance through July 10, 2026.

If you have any questions after reviewing the proposal, please call me.

We look forward to the opportunity of serving Moss.

Sincerely,

*William Powers*

Bill Powers  
Vice President of Sales

Enclosures

**QUOTATION**

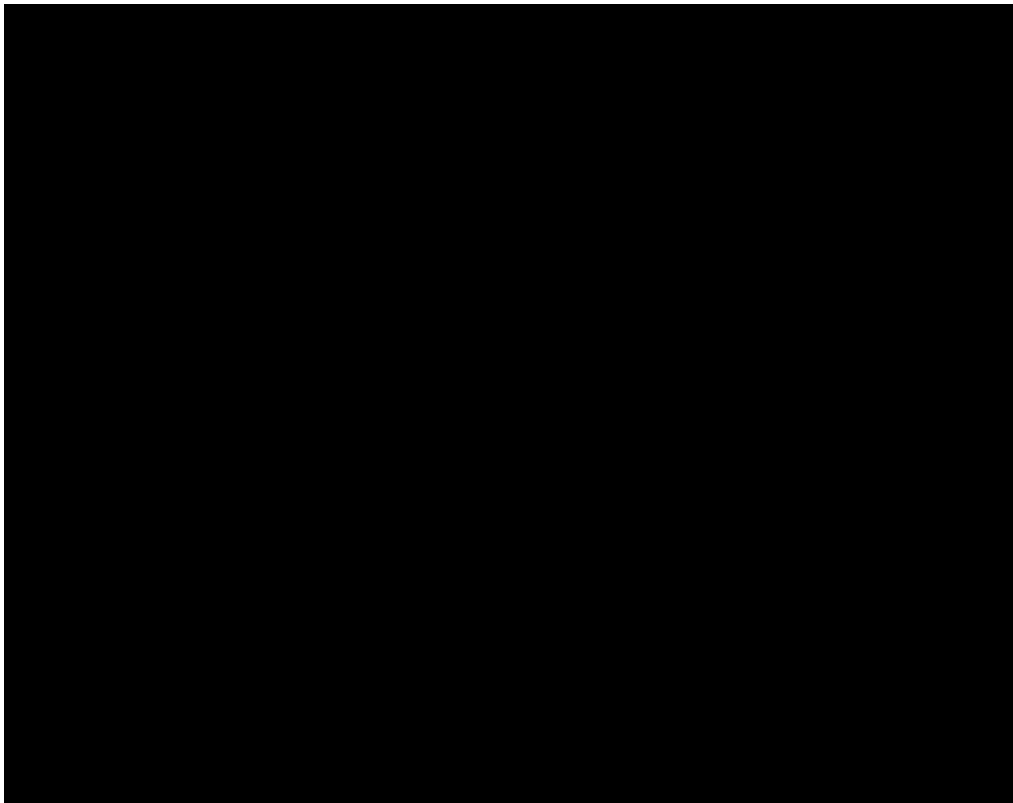
WST 7478 March 24, 2026

BILL TO:	SHIP/INSTALL TO:
Moss Matthew Kane Project Manager 700 NW 1st Ave Fort Lauderdale, FL 33311	Ft. Lauderdale Police Department

Workspace Technology, Inc. will provide and install the following evidence lockers



Qty	Material Price
4	\$8,375
1	\$2,093.75
1	\$3,600
1	\$3,362.50
1	\$3,362.50
1	\$3,568.75
1	\$4,093.75
1	\$4,093.75
1	\$5,500.00



Qty	Material Price
1	\$13,855.00
1	\$1,312.50
2	\$370.00
6	\$787.50
1	\$143.75
5	\$781.25

**Material Price: \$55,300.00**

**Installation: \$4,750.00**

**Freight: \$5,500.00**

(price includes non-union labor during normal business hours)

Salesperson: Bill Powers

Price includes freight, inside delivery, installation, trash removal, clean-up job site, and a one-year warranty. Price does not include Florida State Sales Tax. If additional endorsements on Certificate of Insurance beyond the contract between the end user and Workspace Technology are required, an additional fee of \$500.00 per endorsement will be charged. All credit card transactions are subject to a 3 percent processing fee.

**TERMS:** 50% non-refundable deposit is due with order  
 40% due upon shipment of product  
 Balance 10% due upon completion of installation

Accepted By: \_\_\_\_\_ Date \_\_\_\_\_

# TIFFIN EVIDENCE LOCKERS -

Built to meet the rigorous demands  
of our public safety professionals.  
Our evidence locker line takes  
security to the highest level.

CHAIN OF CUSTODY IS CRITICAL  
IN THE HANDLING OF EVIDENCE.  
WE'VE DESIGNED A SYSTEM TO  
MEET YOUR DEPARTMENT'S  
NEEDS WITH SECURITY AND  
FUNCTIONALITY IN MIND

HEAVY DUTY CONSTRUCTION  
USING 16 GAUGE STEEL

36 STANDARD CONFIGURATIONS  
INCLUDING 18, 24, AND 36"  
WIDE UNITS

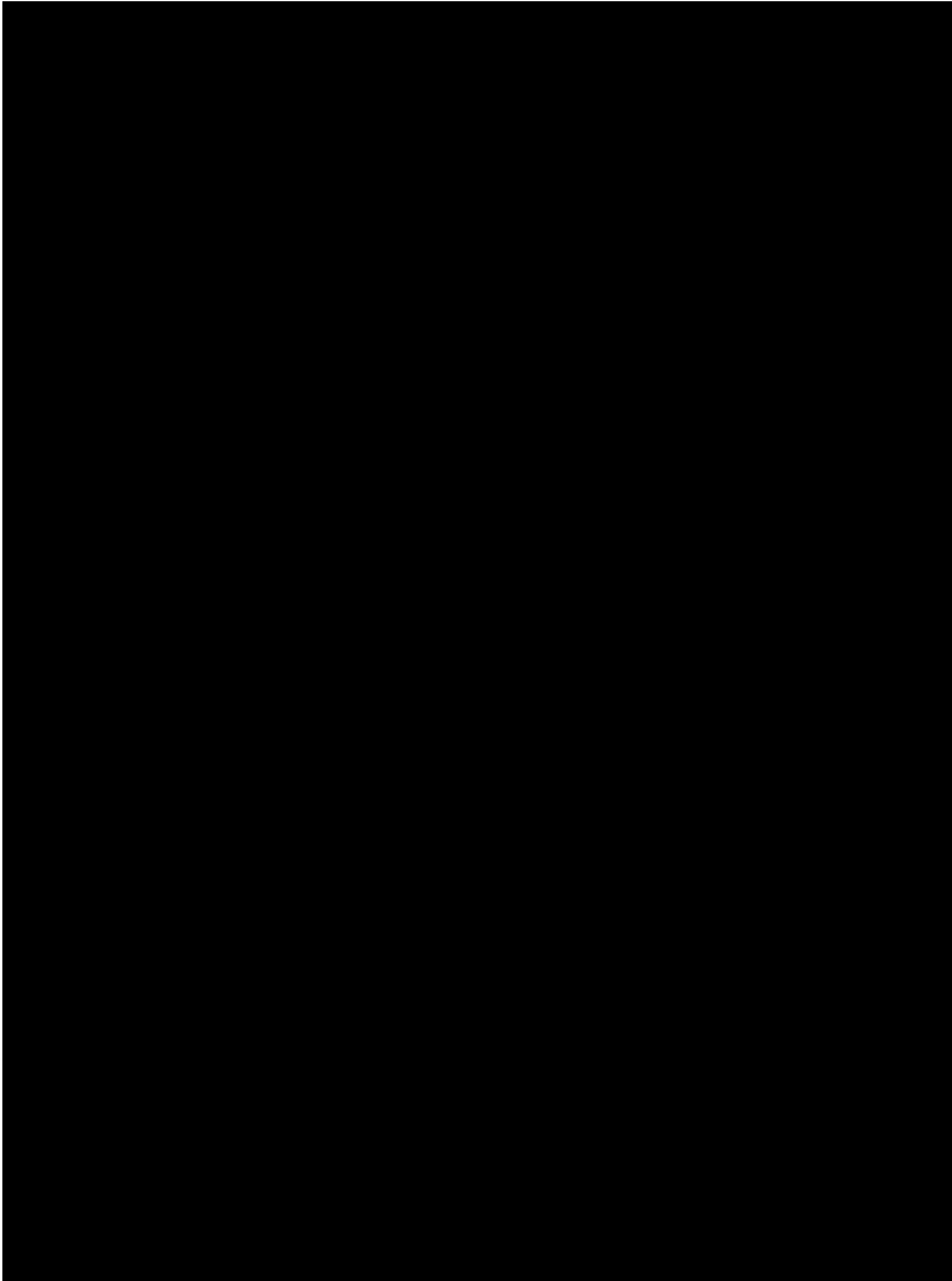
STAND ALONE AND INTEGRAL  
REFRIGERATION OPTIONS AVAILABLE

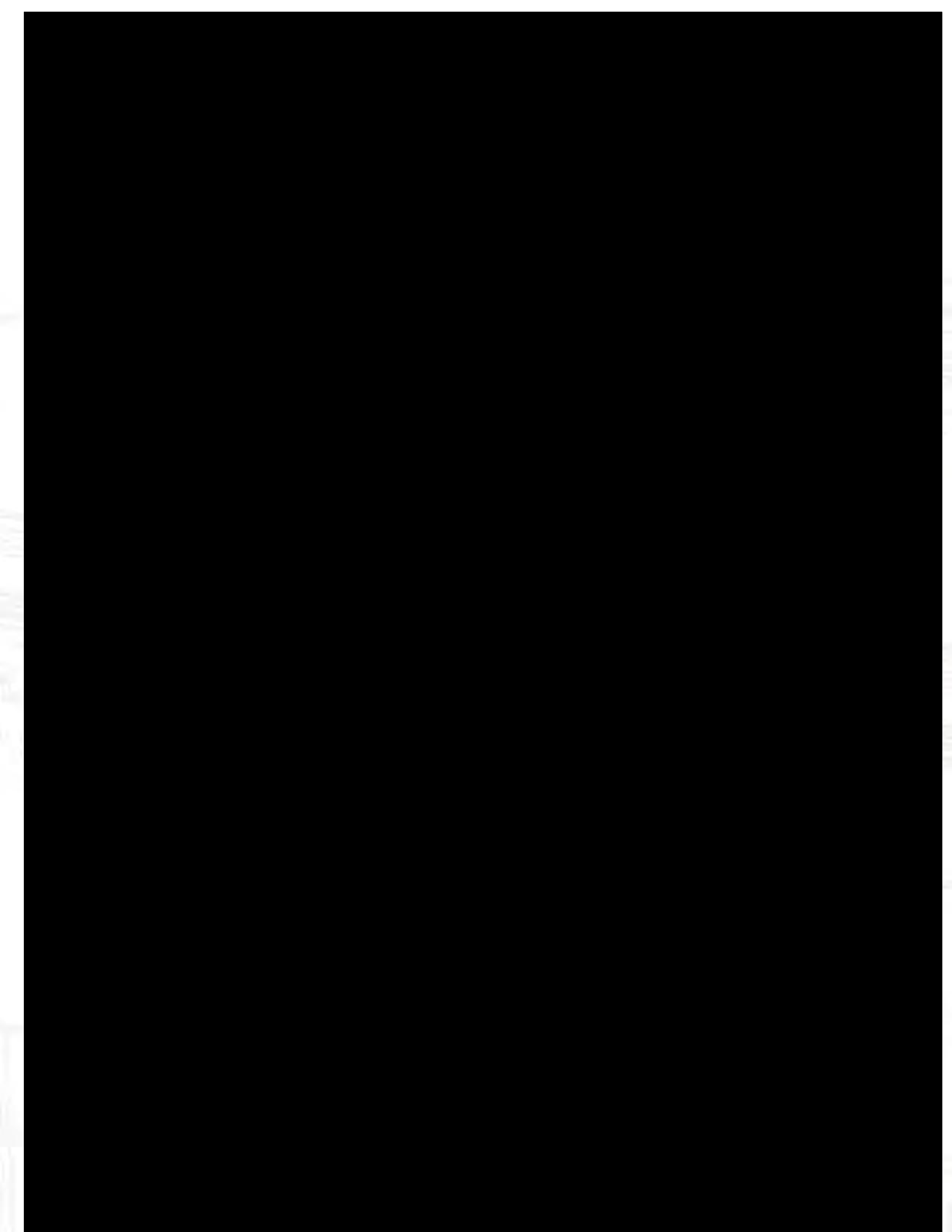
AVAILABLE IN BOTH PASS-THRU  
AND NON PASS-THRU MODELS

VARIETY OF LOCK OPTIONS  
AVAILABLE FOR BOTH KEYED  
AND KEYLESS REQUIREMENTS



STEELE SOLUTIONS







Ordering Information	
Order Placement	<p>Bill Powers            WorkSpace Technology, Inc.            912 N. US Highway 41            Ruskin, FL 33570            Phone: (800)-685-0893            Fax: (908) 454-5633</p>
Delivery	<p>WorkSpace Technology, Inc. will notify your designated contact person twenty-four (24) hours prior to delivery. Dock space will be arranged by you and made available at no cost to WorkSpace Technology, Inc.</p>
Storage	<p>If, for any reason, you are not ready to receive the materials and storage is required, storage and handling fees will be added to your invoice.</p>
Space Requirements	<p>The space shall be ready for installation and free and clear of all obstructions. If it is not and there is a resulting delay, then the additional man-hours will be billed.</p> <p>The space shall be properly lighted. If additional lighting is required to perform the work safely, the additional cost will be invoiced.</p> <p><b>It is your responsibility to be certain the space is suitable for the installation of this equipment, i.e., adequate fire protection, ceiling height clearances, and floor load capacity.</b></p>
Electrical	<p>Electrical power for tools, equipment and lighting will be supplied to WorkSpace Technology, Inc. at no cost.</p>
Installation	<p><b>By certified installers</b>            During normal working hours</p>
Service	<p>For any service requirements, please use our toll free number 1-800-685-0893 and our service team contact you with your service needs.</p>
Taxes	<p>All applicable sales taxes, as required by law, will be billed.</p>
Terms	<p>50% non-refundable deposit is due with order, 40% due upon shipment of product. Balance (10%) due upon completion of installation, net 10 days. All credit card transactions are subject to a 3 percent processing fee.</p> <p>If, for any reason, you cancel the order, any cancellation, restocking and handling charges will be invoiced.</p> <p>If additional endorsements on Certificate of Insurance beyond the contract between the end user and WorkSpace Technology are required, an additional fee of \$500.00 per endorsement will be charged.</p>
Warranty	<p>One year, parts and labor. Full Manufacturer's Warranty Provided.</p>



**Moss & Associates, LLC**  
 6363 NW 6th Way  
 Ft Lauderdale, FL 33309

May 21, 2026

Ronald Stein  
 City of Fort Lauderdale  
 101 NE 3rd Ave, Suite 2100  
 Ft. Lauderdale, FL 33301

RE: Potential Change Item (PCI) 0390 Notification  
 Fort Lauderdale Police Headquarters - B372302

Dear Ronald Stein,

This letter is to provide official notification of a potential change item (PCI) as follows:

PCI Number: 0390  
 Date: April 27, 2026  
 Description: Media Box Receptacles  
 Days Requested:  
 Reason: Owner Directive - External  
 Scope Description: Furnish and install (2) quad receptacles for Media Box Power in west parking lot per PD request.

This PCI is comprised of the following items:

Media Box Receptacles per TEC #03	\$ 11,964.72
01 Subcontract Default Insurance 1.25%	\$ 149.56
02 Moss Insurance 1.75%	\$ 209.38
03 Bond 1%	\$ 119.65
04 Fee 4%	\$ 478.59

<b>Grand Total</b>	<b>\$12,921.90</b>
--------------------	--------------------

Per the terms and conditions of our contract, we have attached the appropriate back up documentation to substantiate the above referenced costs. This request only includes the items specifically identified in this change proposal. All other costs associated with this project shall be submitted under a separate change order cover.

The costs associated with this PCI will remain valid for fourteen (14) calendar days after submission.

Please indicate your formal approval for this additional work and cost by signing in the space provided below. Moss & Associates will then incorporate this change into the next Owner Change Order (OCO).

If you should have any questions, please contact the undersigned at 954-326-2727 as soon as possible.

<p>Sincerely,  <b>Moss &amp; Associates, LLC</b></p> <p>_____ Date: _____</p> <p>Matthew Kane          Sr. Project Manager</p>	<p>Reviewed / Approved by:  <b>City of Fort Lauderdale</b></p> <p><b>Approved:</b> _____ <b>Date:</b> _____          (Owner)</p>
--	--



**SERVICE GROUP**

## FLPD #3R1 Proposal - MEDIA BOX PWR

---

Date: 5/6/2026  
To: Matthew Kane; MOSS  
Project name: FLPD – SITE  
Project address: 1300 W Broward Blvd, Fort Lauderdale, FL, 33312  
Project number: 26-021

This proposal is being provided per ownership's request for the addition of two (2) exterior rated quad receptacles (20A, 120V) to be mounted on the media box rack in the west parking lot area. Power will be fed from Electrical Room 1007, Panel L1F-1, circuits 34 and 36. Conduit sizing, as coordinated with ownership, will consist of 1" EMT and PVC raceway provisions.

**Quoted materials considered are the following:**

- (2) 10" round handholes - (1) for electrical & (1) for communications
- (2) Midwest exterior rated quad receptacles

**Our proposal includes:**

- Wall coring, floor coring, and chipping.
- Mini excavator with 24" bucket rental
- Underground conduit and wire rough in PVC raceways
- Overhead conduit and wire rough in PVC raceways into electrical panels.
- Electrical homerun wire terminations to electrical panel circuit breakers.
- Handhole installation
- Grounding for low voltage surge protection devices (devices provided by Jade Low Voltage)
- Quad NEMA 3R quad enclosure installation and mounting to media box rack
- Wire terminations to quad wiring devices
- Energizing of associated breakers
- Testing of power at wiring devices
- Telephone and service
- Tablet/Computer and software/services
- Delivery & Pickup of materials from TEC warehouse to jobsite
- Sales Tax
- Travel Time/ Offsite Parking
- Clean up

**Our proposal excludes:**

- Reinstallation/ replacement of ceiling tile or access panels.
- Demolition, relocation, protection, or removal of existing or completed millwork.
- Relocation, protection, or removal of furniture.



**SERVICE GROUP**

## **FLPD #3R1 Proposal - MEDIA BOX PWR**

---

- Repair, patching, and/or painting of finishing of any surfaces impacted by the conduit or box required to complete this work.
- Concrete coring, drilling, cutting and/or backfilling.
- Any low voltage cabling, terminations, or free wire cabling support.
- Specialty or custom materials outside of this proposal to be provided by others.
- Any waterproofing.
- Accelerated schedule requirements.
- After hours and/or overtime hours.
- Permit fees.
- All remedial or repair work necessary due to these changes is to be performed by others. Any unforeseen conditions, code requirements, or field conflicts discovered after work begins that impact labor or material shall be addressed via additional cost and time adjustment.

**Clarifications:**

- Bid price is subject to change after 30 days from this bid date
- Any existing conditions, which are not reflected in the plans, but affect the cost of the work, shall be considered an extra to this scope of work.

**Price:**

**\$13,161.19**

Sincerely,

Brandon A. Rodriguez, TEC Service Group

Project Name: PJ -TECSG  
Project Number: PJ -TECSG  
Page Number: 1  
Change Order #: 3R1  
Change Order Date: 5/6/2026

---

**Summary**

---

**MATERIAL**

General Materials		1,602.04	
ANIXTER WIRING DEVICES AND ENCLOSURE		156.34	
Material Tax	(@ 7.000 %)	123.09	
		<hr/>	
<b>Material Total</b>			<b>1,881.47</b>

**LABOR**

SERVICE TECHNICIAN	(72.35 Hrs @ \$95.00)	6,873.25	
SCHEDULER	(1.62 Hrs @ \$75.00)	121.50	
CLEAN UP	(8.00 Hrs @ \$52.00)	416.00	
ESTIMATING	(2.00 Hrs @ \$55.00)	110.00	
		<hr/>	
<b>Total Labor</b>			<b>7,520.75</b>

**EQUIPMENT**

11,000 LB MINI EXCAVATOR W/ 24" BUCKET		1,474.80	
		<hr/>	
<b>Total Equipment</b>			<b>1,474.80</b>

<b>TOTAL MATERIAL, LABOR &amp; EQUIPMENT</b>			<b>10,877.02</b>
--	--	--	------------------

<b>Final Amount</b>			<b>\$13,161.19</b>
---------------------	--	--	--------------------

---

**CLIENT ACCEPTANCE**

---

<b>Name:</b>	_____
<b>Date:</b>	_____
<b>Signature:</b>	_____

I hereby accept this quotation and authorize the contractor to complete the above described work.

Phone: 305-669-1776 Fax: 305-669-1710

**Project Name:** PJ-TECSG  
**Project Number:** PJ-TECSG  
**Page Number:** 2  
**Change Order #:** 3R1  
**Change Order Date:** 5/6/2026

---

**Itemized Breakdown**

---

Drawing	Material(\$)	Labor Hrs
HQ-E1-1-00 REV 5	1,602.03	61.36
HQ-E5-1-14 REV 3	0.00	3.50
<b>Total</b>	<b>1,602.03</b>	<b>64.86</b>

**HQ-E1-1-00 REV 5**

Description	Qty	Net Price U	Total Mat.	Labor U	Total Hrs.
HANDHOLE 18" X 24"	2	0.00 E	0.00	4.00 E	8.00
EXCAVATION (CUBIC YARD)	7	0.00 E	0.00	0.30 E	2.10
BACKFILL (CUBIC YARD)	7	0.00 E	0.00	0.30 E	2.10
COMPACTION (LINEAR FOOT)	199	0.00 E	0.00	0.02 E	3.98
X-RAY FLOOR	1	250.00 E	250.00	0.75 E	0.75
CONCRETE SAW FLOOR	3	0.05 E	0.15	0.20 E	0.60
2" DIAM CORE 8" THICK WALL	1	75.00 E	75.00	1.00 E	1.00
FIRESTOP COMPOUND CAULK (1) PIPE	1	1.00 E	1.00	0.06 E	0.06
1" CONDUIT - EMT	40	257.91 C	103.16	5.60 C	2.24
1" CONN SS STL - EMT	4	377.00 C	15.08	15.00 C	0.60
1" COUPLING SS STL - EMT	4	401.07 C	16.04	0.00 C	0.00
1" LOCKNUT - STEEL	12	89.47 C	10.74	3.88 C	0.47
1" CONDUIT SNAP CLOSE CLIP W/ 1/4-20 THRD HOLE	4	69.13 C	2.77	7.75 C	0.31
1" CONDUIT+BOX SUPPORT W/ 9/32" MNTG HOLE	2	504.20 C	10.08	10.63 C	0.21
1" COUPLING - RMC - GALV PVC CTD	2	1,048.68 C	20.97	35.00 C	0.70
1" ELBOW 90 DEG - RMC - GALV PVC CTD	2	3,296.16 C	65.92	65.00 C	1.30
1" CONDUIT - PVC40	199	70.47 C	140.24	5.50 C	10.95
1" ELBOW 90 DEG - PVC40	12	237.20 C	28.46	27.50 C	3.30
1" COUPLING - PVC	24	64.36 C	15.45	0.00 C	0.00
1" ADAPTER MALE - PVC	12	99.08 C	11.89	15.00 C	1.80
1" ADAPTER FEM - PVC	2	111.28 C	2.23	15.00 C	0.30
1" END BELL - PVC	6	612.71 C	36.76	6.25 C	0.38
1/4-20 MACHINE SCREW ANCHOR	6	29.24 C	1.75	10.00 C	0.60
1/4" THREADED ROD - PLTD	17	68.72 C	11.68	3.13 C	0.53
1/4-20 HEX NUT - PLTD STL	8	3.14 C	0.25	2.50 C	0.20
3/16x 1 1/4 CONCRETE SCREW HEX HEAD - BLUE	8	45.53 C	3.64	8.50 C	0.68
#10 THHN BLACK	1,050	393.32 M	412.99	7.06 M	7.41
#10 THHN GREEN	454	393.32 M	178.57	7.06 M	3.21
# 6 BARE COPPER - 7-STRAND	10	949.67 M	9.50	12.75 M	0.13
WIRE CONN RED (#16 TO #10)	8	17.18 C	1.37	4.50 C	0.36
INSUL DISPLACEMENT WIRE CONN YEL (#12-10)	24	36.00 C	8.64	7.50 C	1.80
1/8" POLYTWINE	262	11.94 M	3.13	3.75 M	0.98

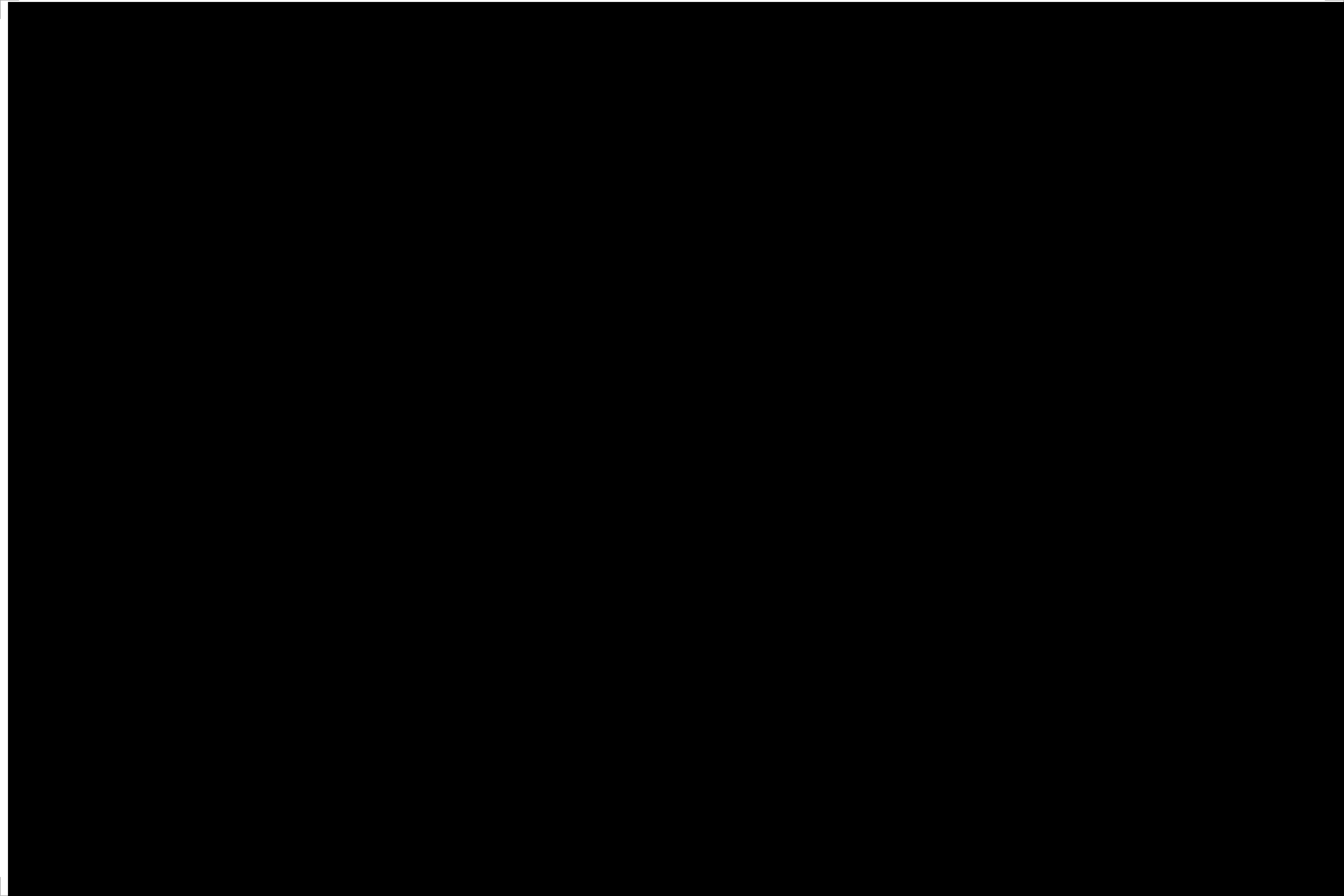
Phone: 305-669-1776 Fax: 305-669-1710

**Project Name:** PJ-TECSG  
**Project Number:** PJ-TECSG  
**Page Number:** 3  
**Change Order #:** 3R1  
**Change Order Date:** 5/6/2026

Description	Qty	Net Price U	Total Mat.	Labor U	Total Hrs.
5/8"x 10' CU CLAD GRD ROD	1	25.06 E	25.06	1.25 E	1.25
3/4"x 10' CU CLAD GRD ROD	1	36.07 E	36.07	1.25 E	1.25
# 4 THRU WIRE TO 1/2 OR 5/8" GRD ROD (32g)	1	0.00 E	0.00	0.31 E	0.31
HANDLE CLAMPS FOR 4" WIDE MOLD	1	91.56 E	91.56	0.00 E	0.00
FLINT IGNITOR	1	10.84 E	10.84	0.00 E	0.00
REPLACEMENT FLINTS FOR IGNITOR	1	1.04 E	1.04	0.00 E	0.00
WELDING MOLD WEAR ALLOWANCE	1	0.00 E	0.00	0.00 E	0.00
QUAD INSTALLATION	2	0.00 E	0.00	0.75 E	1.50
<b>Totals</b>	<b>2,402</b>		<b>1,602.04</b>		<b>61.35</b>

**HQ-E5-1-14 REV 3**

Description	Qty	Net Price U	Total Mat.	Labor U	Total Hrs.
DE-ENERGIZING OF BREAKER(S)	1	0.00 E	0.00	1.00 E	1.00
ENERGIZING OF BREAKER(S)	1	0.00 E	0.00	1.00 E	1.00
WIRE TERMINATION TO BREAKER	2	0.00 E	0.00	0.75 E	1.50
<b>Totals</b>	<b>4</b>		<b>0.00</b>		<b>3.50</b>





**Moss & Associates, LLC**  
 6363 NW 6th Way  
 Ft Lauderdale, FL 33309

May 21, 2026

Ronald Stein  
 City of Fort Lauderdale  
 101 NE 3rd Ave, Suite 2100  
 Ft. Lauderdale, FL 33301

RE: Potential Change Item (PCI) 0391 Notification  
 Fort Lauderdale Police Headquarters - B372302

Dear Ronald Stein,

This letter is to provide official notification of a potential change item (PCI) as follows:

PCI Number: 0391  
 Date: April 27, 2026  
 Description: Blue Phone Provisions  
 Days Requested:  
 Reason: Owner Directive - External  
 Scope Description: Install spare conduit for future blue phone installation by others. Does not include wire or cabling.

This PCI is comprised of the following items:

Blue Phone Provisions per TEC #4	\$ 7,801.85
01 Subcontract Default Insurance 1.25%	\$ 97.52
02 Moss Insurance 1.75%	\$ 136.53
03 Bond 1%	\$ 78.02
04 Fee 4%	\$ 312.07

<b>Grand Total</b>	<b>\$8,425.99</b>
--------------------	-------------------

Per the terms and conditions of our contract, we have attached the appropriate back up documentation to substantiate the above referenced costs. This request only includes the items specifically identified in this change proposal. All other costs associated with this project shall be submitted under a separate change order cover.

The costs associated with this PCI will remain valid for fourteen (14) calendar days after submission.

Please indicate your formal approval for this additional work and cost by signing in the space provided below. Moss & Associates will then incorporate this change into the next Owner Change Order (OCO).

If you should have any questions, please contact the undersigned at 954-326-2727 as soon as possible.

<p>Sincerely,  <b>Moss &amp; Associates, LLC</b></p> <p>_____ Date: _____</p> <p>Matthew Kane          Sr. Project Manager</p>	<p>Reviewed / Approved by:  <b>City of Fort Lauderdale</b></p> <p><b>Approved:</b> _____ <b>Date:</b> _____          (Owner)</p>
--	--

Date: 5/4/2026  
To: Matthew Kane; MOSS  
Project name: FLPD – SITE  
Project address: 1300 W Broward Blvd, Fort Lauderdale, FL, 33312  
Project number: 26-021

This proposal is being provided at the request of ownership for the labor and materials associated with the addition of a Code Blue public help phone and light station for the site portion of the project. Product data and specification sheets were not provided at the time of pricing. Typical power requirements were assumed based on manufacturer information from the Code Blue website and used as the basis for this proposal for sizing of conduits.

As requested, this proposal includes only the installation of handholes and underground conduit raceways from the AV/IT Room 1007 slab to the general vicinity of the proposed Code Blue device location. Final device locations, site layout, and field survey are to be provided by others. Layout, design, and coordination of exact installation points are not included in Thunder Electric's scope under this proposal.

Any revisions required due to changes in device specifications, power requirements, or site layout once finalized may result in additional costs.

**Quoted materials considered are the following:**

- (2) 10" round handholes - (1) labeled "Electrical" & (1) labeled "Communications"
- (1) 17"x30"x24" composite handhole, labeled "Communications"

**Our proposal includes:**

- Wall coring, floor coring, and chipping.
- Mini excavator with 24" bucket rental
- Underground conduit rough in PVC raceways with Jetline from Code Blue handhole location into AV/IT RM 1007.
- Handhole installation
- Telephone and service
- Tablet/Computer and software/services
- Delivery & Pickup of materials from TEC warehouse to jobsite
- Sales Tax
- Travel Time/ Offsite Parking
- Clean up

**Our proposal excludes:**

- Reinstallation/ replacement of ceiling tile or access panels.
- Wiring of power conductors.
- Grounding for Low Voltage surge protection.





**Project Name:** PJ-TECSG  
**Project Number:** PJ-TECSG  
**Page Number:** 1  
**Change Order #:** FLPD - 4R1  
**Change Order Date:** 5/4/2026

---

**Summary**

---

<b>MATERIAL</b>			
General Materials		578.39	
ANIXTER		488.75	
Material Tax	(@ 7.000 %)	74.70	
		<hr/>	
<b>Material Total</b>			<b>1,141.84</b>

<b>LABOR</b>			
SERVICE TECHNICIAN	(39.71 Hrs @ \$95.00)	3,772.45	
SCHEDULER	(0.90 Hrs @ \$75.00)	67.50	
CLEAN UP	(8.00 Hrs @ \$52.00)	416.00	
ESTIMATING	(3.00 Hrs @ \$55.00)	165.00	
AS-BUILT DRAWINGS	(1.00 Hrs @ \$55.00)	55.00	
		<hr/>	
<b>Total Labor</b>			<b>4,475.95</b>

<b>EQUIPMENT</b>			
11,000 LB MINI EXCAVATOR W/ 24" BUCKET		1,474.80	
		<hr/>	
<b>Total Equipment</b>			<b>1,474.80</b>

**TOTAL MATERIAL, LABOR & EQUIPMENT** **7,092.59**

**Final Amount** **\$8,582.04**

---

**CLIENT ACCEPTANCE**

<b>Name:</b>	<hr/>
<b>Date:</b>	<hr/>
<b>Signature:</b>	<hr/>

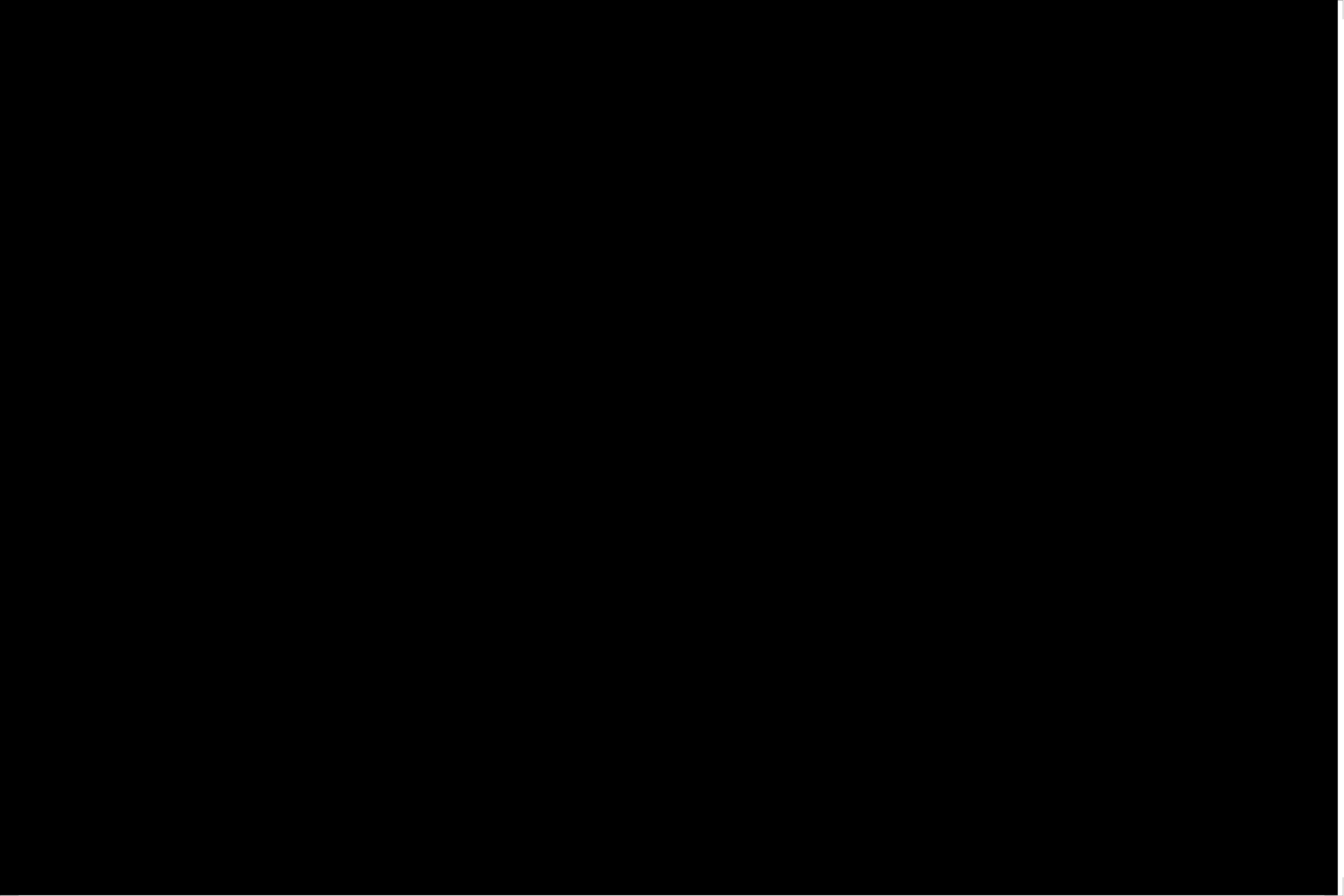
I hereby accept this quotation and authorize the contractor to complete the above described work.  
 Phone: 305-669-1776 Fax: 305-669-1710



**Project Name:** PJ-TECSG  
**Project Number:** PJ-TECSG  
**Page Number:** 2  
**Change Order #:** FLPD - 4R1  
**Change Order Date:** 5/4/2026

**Itemized Breakdown**

Description	Qty	Net Price U	Total Mat.	Labor U	Total Hrs.
FIBERGLASS HANDHOLE 18" X 24"	2	0.00 E	0.00	1.25 E	2.50
EXCAVATION (CUBIC YARD)	17	0.00 E	0.00	0.30 E	5.10
BACKFILL (CUBIC YARD)	17	0.00 E	0.00	0.30 E	5.10
COMPACTION (LINEAR FOOT)	262	0.00 E	0.00	0.02 E	5.24
2" DIAM CORE 6" THICK FLOOR	2	110.00 E	220.00	0.75 E	1.50
2" DIAM CORE 4" THICK WALL	1	75.00 E	75.00	0.00 E	0.00
2" DIAM CORE 8" THICK WALL	1	75.00 E	75.00	0.00 E	0.00
FIRESTOP COMPOUND CAULK (1) PIPE	2	1.00 E	2.00	0.06 E	0.12
3/4" CONDUIT - PVC40	130	44.33 C	57.63	4.50 C	5.85
1" CONDUIT - PVC40	133	70.47 C	93.73	5.50 C	7.32
3/4" ELBOW 90 DEG - PVC40	4	156.60 C	6.26	23.75 C	0.95
1" ELBOW 90 DEG - PVC40	4	237.20 C	9.49	27.50 C	1.10
3/4" COUPLING - PVC	8	42.40 C	3.39	0.00 C	0.00
1" COUPLING - PVC	10	64.36 C	6.44	0.00 C	0.00
3/4" END BELL - PVC	2	686.56 C	13.73	6.25 C	0.13
1" END BELL - PVC	2	612.71 C	12.25	6.25 C	0.13
1/8" POLYTWINE	291	11.94 M	3.47	3.75 M	1.09
<b>Totals</b>	<b>888</b>		<b>578.39</b>		<b>36.12</b>



## Brandon Rodriguez

---

**From:** Ronald Stein <RStein@fortlauderdale.gov>  
**Sent:** Monday, April 20, 2026 4:20 PM  
**To:** Brandon Rodriguez; John-James Yancey; Andres Hernandez; Matthew Kane; James Pope; Tiago Lima  
**Cc:** Pedro J. Hernandez  
**Subject:** RE: FLPH -Media Box Pwr and LV Coordination

All  
There are no specifications at this time.  
Please just terminate the conduits in a small handhole.  
Thanks  
Ron

**Ronald Stein**  
**Sr. Project Manager**  
101 NE 3<sup>rd</sup> Ave, Suite 2100 | Fort Lauderdale FL 33301  
City of Fort Lauderdale  
C: (954) 531-2395 | E: [RStein@fortlauderdale.gov](mailto:RStein@fortlauderdale.gov)



---

**From:** Brandon Rodriguez <brandon@thunder-electric.com>  
**Sent:** Monday, April 20, 2026 4:18 PM  
**To:** John-James Yancey <jjyancey@moss.com>; Ronald Stein <RStein@fortlauderdale.gov>; Andres Hernandez <AHernandez@fortlauderdale.gov>; Matthew Kane <mkane@moss.com>; James Pope <jpope@moss.com>; Tiago Lima <tlima@moss.com>  
**Cc:** Pedro J. Hernandez <pedro@thunder-electric.com>  
**Subject:** [EXTERNAL:CAUTION!]- RE: FLPH -Media Box Pwr and LV Coordination

**[::CAUTION!:] This email originated from *outside* The City of Fort Lauderdale. Do Not Reply, click links, or open attachments from an unknown or suspicious origin. Confirm the email address is from an expected source before taking action. Report any suspicious emails to [spamadmin@fortlauderdale.gov](mailto:spamadmin@fortlauderdale.gov)**

---

[@Ronald Stein](#) [@Andres Hernandez](#)

Following up on the product data and specs for the Code Blue public emergency phone and light station. Are those available yet?

**Brandon Rodriguez**  
Thunder Electrical Contractors Inc.



7035-F SW 47 St., Miami, FL 33155  
M:786-920-3582 - O:305-669-1776  
E: [brandon@thunder-electric.com](mailto:brandon@thunder-electric.com)

---

**From:** John-James Yancey <[jjyancey@moss.com](mailto:jjyancey@moss.com)>  
**Sent:** Wednesday, April 15, 2026 9:49 AM  
**To:** Ronald Stein <[rstein@fortlauderdale.gov](mailto:rstein@fortlauderdale.gov)>; Andres Hernandez <[ahernandez@fortlauderdale.gov](mailto:ahernandez@fortlauderdale.gov)>; Brandon Rodriguez <[brandon@thunder-electric.com](mailto:brandon@thunder-electric.com)>; LBARRET\_CU <[laxleyb@jade-com.com](mailto:laxleyb@jade-com.com)>; Matthew Kane <[mkane@moss.com](mailto:mkane@moss.com)>  
**Cc:** Tiago Lima <[tlima@moss.com](mailto:tlima@moss.com)>; James Pope <[jpope@moss.com](mailto:jpope@moss.com)>  
**Subject:** FLPH -Media Box Pwr and LV Coordination

Good morning everyone,

Thank you for your participation with the media box coordination today. Please see the attached mark up, which summarizes everything we discussed today.

If you see any issues or have concerns, please let me know. Thank you.

Regards,

John-James (JJ) Yancey  
Assistant Superintendent  
**Moss**  
Direct: 954-295-0856  
[moss.com](http://moss.com)



**Moss & Associates, LLC**  
 6363 NW 6th Way  
 Ft Lauderdale, FL 33309

May 05, 2026

Ronald Stein  
 City of Fort Lauderdale  
 101 NE 3rd Ave, Suite 2100  
 Ft. Lauderdale, FL 33301

RE: Potential Change Item (PCI) 0392 Notification  
 Fort Lauderdale Police Headquarters - B372302

Dear Ronald Stein,

This letter is to provide official notification of a potential change item (PCI) as follows:

PCI Number: 0392  
 Date: April 27, 2026  
 Description: Chief's Conference Ceiling Blackout  
 Days Requested:  
 Reason: Owner Directive - External  
 Scope Description: Install black BioAcoustic infill panels above slat ceiling and paint perimeter black.

This PCI is comprised of the following items:

6657 BioAcoustic Infill Panels	\$ 14,000.00
Chief's Conference Perimeter Ceiling Paint	\$ 1,793.00
01 Subcontract Default Insurance 1.25%	\$ 197.41
02 Moss Insurance 1.75%	\$ 276.38
03 Bond 1%	\$ 157.93
04 Fee 4%	\$ 631.72

<b>Grand Total</b>	<b>\$17,056.44</b>
--------------------	--------------------

Per the terms and conditions of our contract, we have attached the appropriate back up documentation to substantiate the above referenced costs. This request only includes the items specifically identified in this change proposal. All other costs associated with this project shall be submitted under a separate change order cover.

The costs associated with this PCI will remain valid for fourteen (14) calendar days after submission.

Please indicate your formal approval for this additional work and cost by signing in the space provided below. Moss & Associates will then incorporate this change into the next Owner Change Order (OCO).

If you should have any questions, please contact the undersigned at 954-326-2727 as soon as possible.

<p>Sincerely,  <b>Moss &amp; Associates, LLC</b></p> <p>_____ Date: _____</p> <p>Matthew Kane          Sr. Project Manager</p>	<p>Reviewed / Approved by:  <b>City of Fort Lauderdale</b></p> <p><b>Approved:</b> _____ <b>Date:</b> _____          (Owner)</p>
--	--



**Corporate Office / Remit To**  
**Lotspeich Co. of Florida, Inc.**  
 6351 NW 28<sup>th</sup> Way, Suite A  
 Ft. Lauderdale, FL 33309  
 Phone: (954) 978-2388  
 Website: www.lcfinc.com

**West Palm Beach Office**  
 7435 Central Industrial Drive, Suite A  
 Riviera Beach, FL 33404  
 Phone: (954) 978-2388  
 Website: www.lcfinc.com

**Drywall Construction ■ Acoustical Ceilings ■ Doors & Hardware ■ Building Specialties**  
**Exterior Finishes-Metal Framing, Sheathing, Stucco, EIFS, Exterior Cladding Systems**

Project Name:	FTLP Chief Conference Room - Ceiling Changes	Proposal Date:	04/27/2026
Location:	1300 W Broward BLvs Fort Lauderdale, FL 33312	Revised On:	
Attention:	Moss Construction Matthew Kane	LCF PM:	Connor Nitterauer
		LCF Est:	
Scope of Work:	Acoustical Ceilings		

We propose to furnish the necessary labor and/or materials for the above-named project.

**ARCHITECT:**  
**PLAN DATE:**  
**ADDENDUM:**  
**RFI:**

**SCOPE OF WORK:** Acoustical Ceiling.

- Special Conditions:** Our proposal assumes the following regarding General Conditions & Requirement:
1. Supervision is included.
  2. Labor rates are based on 40hr workweeks.
  3. Nearby parking provided by GC at no cost Lotspeich.
  4. Daily clean-up of our debris/waste to GC furnished dumpsters or trash chutes (if necessary) is included.
  5. Stocking during normal working hours with means of hoisting above 2 floors to be provided by GC.
  6. Adequate temporary power, lighting, and water by GC.
  7. Add 1.25% if bond is required.
  8. Price commitment is based on acceptance within 30 days and materials to be shipped to the job site on or 06/01/2026. If Work is contracted later, we reserve right to update material cost based on then current costs.

**ALTERNATE ADD: \$14,000.00**

- Provide and install 6657 BioAcoustic Infill Panel above Chief Conference Room Wood Ceiling
- NRC of .75 provided
- Material: \$7,700 Labor: \$6,300 (80 hrs @ \$78.75/hr)

**ALTERNATE ADD: \$11,000.00**

- Provide and install 8200T10 BioAcoustic Infill Panel above Chief Conference Room Wood Ceiling
- NRC of .75 provided



**Corporate Office / Remit To**  
**Lotspeich Co. of Florida, Inc.**  
 6351 NW 28<sup>th</sup> Way, Suite A  
 Ft. Lauderdale, FL 33309  
 Phone: (954) 978-2388  
 Website: www.lcfinc.com

**West Palm Beach Office**  
 7435 Central Industrial Drive, Suite A  
 Riviera Beach, FL 33404  
 Phone: (954) 978-2388  
 Website: www.lcfinc.com

**Drywall Construction ■ Acoustical Ceilings ■ Doors & Hardware ■ Building Specialties**  
**Exterior Finishes-Metal Framing, Sheathing, Stucco, EIFS, Exterior Cladding Systems**

**"This proposal is based on current material pricing and is subject to adjustment in the event of significant changes in material costs due to tariffs, trade restrictions, or supply chain disruptions. The contractor reserves the right to pass through any additional costs incurred as a result of new or increased tariffs that impact the project scope. Any such cost adjustments will be documented and presented for client review and approval prior to implementation".**

**This proposal shall constitute a Contract when signed by both parties. This proposal is valid for 30 days. If not accepted within 30 days, pricing may be subject to change or such offer may be terminated.**

**LOTSPEICH CO. of FLORIDA, INC.**

Connor Nitterauer

04/27/2026

Date

Project Manager

Title

**CUSTOMER'S ACCEPTANCE**

Accepted by the undersigned subject to the conditions above.

Authorized Representative Signature

Date

Print Name

# ACOUSTICAL INFILL PANELS

Accessories for MetalWorks™ and WoodWorks® Ceilings



WoodWorks Grille Tegular 24" × 24" panels with 2820 infill panels



MetalWorks Torsion Spring custom perforated panels

Smooth mineral fiber ceiling panel with excellent sound absorption for open plan spaces.

## KEY SELECTION ATTRIBUTES

- Enhance design and increase sound absorption with a variety of acoustical infill options for MetalWorks™ and WoodWorks® panels
- BioAcoustic™ infill can contribute to LEED® credits (Rapidly renewable and recycled content)
- Custom-size BioAcoustic panels available; for details, contact – ASQuote@armstrongceilings.com
- Made in the U.S.A. of domestic and global content
- Build America, Buy America (BABA) Act compliant

## TYPICAL APPLICATIONS

- Office
- Education
- Healthcare
- Hospitality and retail
- Transportation

## DETAILS



- BioAcoustic Infill Panel – Beige
- BioAcoustic Infill Panel – Black
- Backstage Noir® Square Lay-in Panel – Black
- 1" Fiberglass Infill Panel (in poly bag)
- Fine Fissured™ Square Lay-in Panel – Black
- Cortega® Square Lay-in Panel
- Calla® Square Lay-in Panel – Black

# ACOUSTICAL INFILL PANELS

Accessories for MetalWorks™ and WoodWorks® Ceilings

## ACOUSTICAL INFILL PANELS

## ACOUSTICAL PERFORMANCE

Item No.	Description	Dimensions (Nominal W × L × H)	Color	PCS/CTN	Sound Absorption NRC	Sound Blocking SAC	Total Acoustics <sup>1</sup> CAC
2820/2820BK	Calla® Square Lay-in Panel	24 × 24 × 1"	White or Black	10	0.85	35	BEST
2821BK	Calla Square Lay-in Panel	24 × 48 × 1"	Black	10	0.85	35	BEST
2864BK	Calla Square Lay-in Panel	24 × 72 × 1"	Black	10	0.85	35	BEST
1713/1713BL	School Zone® Fine Fissured™ Square Lay-in Panel	24 × 24 × 3/4"	White or Black	12	0.70	35	BETTER
1714	School Zone Fine Fissured Square Lay-in Panel	24 × 48 × 3/4"	White	8	0.70	40	BETTER
1318	Backstage Noir® Square Lay-in Panel	24 × 24 × 3/4"	Black	12	0.75	30	N/A
1319	Backstage Noir Square Lay-in Panel	24 × 48 × 3/4"	Black	6	0.75	30	N/A
5479	BioAcoustic™ Infill Panel	24 × 24 × 5/8"	Beige Matte	12	0.75	N/A	N/A
5823	BioAcoustic Infill Panel	24 × 24 × 5/8"	Black Matte	12	0.75	N/A	N/A
6657	BioAcoustic Infill Panel	11 × 48 × 5/8"	Black Matte	12	0.75	N/A	N/A
8200T10	Fiberglass Infill Panel	24 × 24 × 1"	Black Gloss	12	0.75	N/A	N/A
747*	Cortega® Square Lay-in Panel	24 × 48 × 5/8"	White	8	0.55	40	N/A
1728BL	Fine Fissured™ Square Lay-in Panel	24 × 24 × 5/8"	Tech Black	16	0.55	33	N/A

\* Recommended for high CAC acoustical performance with MetalWorks Extra Microperforated panels.  
<sup>1</sup> Total Acoustics<sup>®</sup> ceiling panels have an ideal combination of sound absorption and sound blocking in one product.  
**GOOD** (NRC 0.60-0.65; SAC 35+) **BETTER** (NRC 0.70-0.75; SAC 35+) **BEST** (NRC 0.80+; SAC 35+)

## PHYSICAL DATA

**Material**  
 8200T10 – fiberglass  
 1728BL, 747, 2820/2920BK, 2821BK, 2864BK, 1318, 1319, 1713/1713BL, 1714 – wet-formed mineral fiber  
 5479, 5823, 6657 – BioAcoustic

**Surface Finish**  
 See photos on previous page for visual

**Fire Performance**  
 For all panels (excluding 5823 and 6657) – Class A:  
 ASTM E84 and CAN/ULC S102 surface burning characteristics. Flame Spread Index 25 or less. Smoke Developed Index 50 or less. Class A.  
 For 5823 and 6657 – ASTM E84 Flame Spread Index 25 or less. Smoke Developed Index 450 or less. Class A. CAN/ULC S102.2 surface burning characteristics. Flame Spread Rating of 25. Smoke Developed Classification of 50.

**ASTM E1264 Classification**  
 2820/2820BK, 2821BK, 2864BK, 1318, 1319 – Type A Form A2.2, Pattern G; Fire Class A  
 1713/1713BL, 1714, 1728BL – Type A, Form A1.2, Pattern D; Fire Class A  
 5479, 5823, 6657 – Type B, Form 2, Pattern C E  
 747 – Type A, Form A1.2, Pattern E; Fire Class A

**VOC Emissions**  
 Compliant with California Department of Public Health CDPH/EHLB/Standard Method Version 1.2, 2012. This standard is the guideline for low emissions in LEED®, WELL Building Standard™, Living Building Challenge® (LBC), CalGreen Title 24, ANSI/ASHRAE/USGBC/IES Standard 189: ANSI/GBI Green Building Assessment Protocol.

**Anti Mold/Mildew**  
 8200T10 – Fiberglass substrate is inherently resistant to the growth of mold, mildew, and bacteria. 2820, 2820BK, 2821BK, 2864BK, 1713, 1713BL, 1714, 1318, 1319, 747, 1728BL – Ceiling panels with BioBlock® performance resist the growth of mold and mildew on the panel surface. 5479, 5823, 6657 – standard performance

**Insulation Value**  
 2820/2820BK, 2821BK, 2864BK – R Factor – 2.9 (BTU units); R Factor – 0.445 (Watts units)  
 1318, 1319 – R Factor – 2.2 (BTU units); R Factor – 0.39 (Watts units)  
 1713/1713BL, 1714, 1728BL – R Factor – 1.5 (BTU units); R Factor – 0.26 (Watts units)  
 5479, 5823, 6657 – 1.6 (BTU units); R Factor – 0.28 (Watts units)  
 747 – R Factor – 1.5 (BTU units); R Factor – 0.28 (Watts units)

**Weight: Square Feet/ Carton**  
 747 – 1.09 LBS/SF; 64 SF/CTN  
 1728BL – 0.70 LBS/SF; 64 SF/CTN  
 8200T10 – 0.09 LBS/SF; 48 SF/CTN  
 5479, 5823 – 0.22 LBS/SF; 48 SF/CTN  
 2821BK – 1.0 LBS/SF; 48 SF/CTN  
 2864BK – 1.0 LBS/SF; 72 SF/CTN  
 2820/2820BK – 1.0 LBS/SF; 40 SF/CTN  
 1318, 1319 – 1.08 LBS/SF; 48 SF/CTN  
 1713, 1713BL – 1.31 LBS/SF; 48 SF/CTN  
 1714 – 1.38 LBS/SF; 64 SF/CTN



15461 SW 12th Street, Suite 105  
Sunrise, FL 33326  
Phone: (305) 364-5092  
Fax: (239) 939-1543

Submitted to: Moss & Associates, LLC  
2101 N Andrews Ave  
Ft. Lauderdale, FL 33311

Phone: 408-854-9042

Attn: Matthew Kane

Date: April 27, 2026

### Ft Lauderdale Police HQ

Per plans and specifications, Service Contracting Solutions proposes the following scope of work and pricing for the above referenced project.

#### ADDENDA RECEIVED:

Email dated 4.10.26

#### SCOPE OF WORK - PAINTING

Paint perimeter of wood ceiling in Chief's Conference room black with 2 coats of ProMar 200 Flat.

#### COST BREAKOUT:

LABOR 32 HRS @ \$50.00 PER =	\$1,600
MATERIALS - 2 GALS. PROMAR 200 FLAT @ \$14.15 PER =	\$28
SALES TAX ON MATERIALS (7%) =	\$2
OH&P MARKUP (10%) =	\$163
<b>TOTAL:</b>	<b>\$1,793</b>

#### EXCLUSIONS & QUALIFICATIONS:

1. All prices on this quotation are valid for 30 days.
2. For P&P Bond, add 2%.

For Buy-out questions call:

SERVICE CONTRACTING SOLUTIONS

*Wilbur Lozano*

Project Manager

15461 SW 12th Street, Suite 105

Sunrise, FL 33326

786-424-8826 CELL

305-364-5092 OFFICE

[E-mail: will@servicecontracting.com](mailto:will@servicecontracting.com)

[Web Site: www.servicecontracting.com](http://www.servicecontracting.com)



**Moss & Associates, LLC**  
 6363 NW 6th Way  
 Ft Lauderdale, FL 33309

May 21, 2026

Ronald Stein  
 City of Fort Lauderdale  
 101 NE 3rd Ave, Suite 2100  
 Ft. Lauderdale, FL 33301

RE: Potential Change Item (PCI) 0394 Notification  
 Fort Lauderdale Police Headquarters - B372302

Dear Ronald Stein,

This letter is to provide official notification of a potential change item (PCI) as follows:

PCI Number: 0394  
 Date: May 04, 2026  
 Description: Swap Combi-oven for (2) Multi Oven  
 Days Requested:  
 Reason: Owner Directive - External  
 Scope Description: Replace upper stacked combi oven with (2) multi ovens. Includes custom shelf for multi ovens. Also includes credit for condiment counter and add for misc. accessories per food service consultant,  
 Includes power provisions for added electrical for ovens.

This PCI is comprised of the following items:

RCO 1 Multi Oven Swap	\$ -8,893.96
RCO 2 Refrigerant Change	\$ 1,059.30
Power for additional oven	\$ 4,693.23
01 Subcontract Default Insurance 1.25%	\$ -39.27
02 Moss Insurance 1.75%	\$ -54.98
03 Bond 1%	\$ -31.41
04 Fee 4%	\$ -125.66
<b>Grand Total</b>	<b>\$-3,392.75</b>

Per the terms and conditions of our contract, we have attached the appropriate back up documentation to substantiate the above referenced costs. This request only includes the items specifically identified in this change proposal. All other costs associated with this project shall be submitted under a separate change order cover.

The costs associated with this PCI will remain valid for fourteen (14) calendar days after submission.

Please indicate your formal approval for this additional work and cost by signing in the space provided below. Moss & Associates will then incorporate this change into the next Owner Change Order (OCO).

If you should have any questions, please contact the undersigned at 954-326-2727 as soon as possible.

<p>Sincerely,  <b>Moss &amp; Associates, LLC</b></p> <p>_____ Date: _____</p> <p>Matthew Kane          Project Manager</p>	<p>Reviewed / Approved by:  <b>City of Fort Lauderdale</b></p> <p><b>Approved:</b> _____ <b>Date:</b> _____          (Owner)</p>
--	--

04/17/2026

# Request For Change Order


To: Moss & Associates  
 Mathew Kane  
 6363 NW 6th Way  
 Fort Lauderdale, FL 33309

From: Baring Industries, Inc.  
 Gina Pagan  
 3249 SW 42nd Street  
 Fort Lauderdale, FL 33312-6810  
 (954)327-6700  
 954-327-6725 (Contact)

Project: 251061-RCO 1 Cut Book Submittal  
 changes & scope review Rev.2

Per client's cutbook submittal return and scope review, the following changes  
 have been requested.

Thank you for the opportunity and we look forward to working  
 with you in the near future.

Item	Qty	Description	Sell	Sell Total
004.R	-1 ea	<b>COMBI VECTOR STACKED</b>  Alto-Shaam 7-20G PRO Combi-Vector Pre-Stacked Configuration, (6-10 or 7-20) Combi Oven stacked on VMC-F4E or VMC-F4G) Multi-Cook Oven, electric, (Configure for pricing)-Prodigi™ Pro Combi Oven/Steamer, gas, boiler-free, countertop, (7) 18" x 26" full size sheet or (16) 12" x 20" full size hotel pan (GN 1/1) capacity, Wi-Fi enabled control with steam/convection/combi cooking modes, programmable cool-down, SafeVent™ steam venting, removable "T" style temperature probe, (3) power levels, (5) cleaning levels, triple-pane door, (2) side racks with (8) non-tilt support rails, (4) shelves, high efficiency LED lighting, door hinged right, stainless steel construction, adjustable stainless steel legs, 98,000 BTU, EcoSmart®, cULus, UL EPH Classified, CE, IPX5, EAC, ENERGY STAR®	\$19,270.00	\$-19,270.00
	-1 kt	5026980 Installation Kit, for gas combi ovens, Copper, rated up to 20.0 amps, per oven ((NET) NO FURTHER DISCOUNTS APPLY) (Note: Required to meet NYC requirements)	\$975.00	\$-975.00
	-1 ea	208-240v/50/60/1-ph, 4.8-4.2 amps, 1.0kW, 14 AWG, NO cord or plug	\$156.00	\$-156.00
	-1 ea	HO-36870 HO-36870 Hose, 3/4" NPT, 6' long; NOTE: installation kits only contain 2 hoses, a third inlet hose is required to connect the water filtration system	\$100.00	\$-100.00
	-1 ea	Recessed Door, for 7-20s (security package not available with this option)	\$2,421.00	\$-2,421.00
	-1 ea	Pump-style, automatic grease collection, includes (4) 6-piece poultry	\$1,397.00	\$-1,397.00



Item	Qty	Description	Sell	Sell Total
		racks #5014438, interior drip collection pan and grease collection container with shut-off valve		
	-1 ea	5032550 Stacking Hardware, Combi over Vector F Gas, includes mobile base for bottom unit, for GAS units only	\$1,378.00	\$-1,378.00
			<b>Extended Total:</b>	<b>\$-25,697.00</b>
004	1 ea	<b>COMBI OVEN, GAS</b> Alto-Shaam 7-20G PRO Prodigi™ Pro Combi Oven/Steamer, gas, boiler-free, countertop, (7) 18" x 26" full size sheet or (16) 12" x 20" full size hotel pan (GN 1/1) capacity, Wi-Fi enabled control with steam/convection/combi cooking modes, programmable cool-down, SafeVent™ steam venting, removable "T" style temperature probe, (3) power levels, (5) cleaning levels, triple-pane door, (2) side racks with (8) non-tilt support rails, (4) shelves, high efficiency LED lighting, door hinged right, stainless steel construction, adjustable stainless steel legs, 98,000 BTU, EcoSmart®, cULus, UL EPH Classified, CE, IPX5, EAC, ENERGY STAR®	\$18,769.00	\$18,769.00
	1 ea	5017391 Mobile Stacking Base, for 7-20 or 10-20 model ovens	\$472.00	\$472.00
	1 ea	NOTE: Subject to Manufacturer's Terms & Conditions. See Documents Section		
	1 ea	12 month extended warranty to begin at the end of std. warranty & continue for 12 additional months (net)	\$745.00	\$745.00
	1 ea	Alto-Shaam Certified Chef provides complimentary support and training on all Alto-Shaam combi ovens		
	1 ea	It is the sole responsibility of the owner/operator/purchaser of this equipment to verify that the incoming water supply is comprehensively tested and, if required, provide a means of water treatment that would meet the compliance requirements with the manufacturers water quality standards published on the product spec sheet. Non-compliance with these minimum standards will potentially damage this equipment and/or components and VOID the original equipment manufacturers warranty		
	1 ea	XP-PRE SITE SURVEY Pre-Site Survey (Installation must be purchased to purchase pre-site survey) • Travel within 100 miles (200 miles round trip) for one trip • Perform pre-install site visit • Complete pre-installation checklist on up to four units at the same time/place Pre-site is not included in the purchase of an installation and will need to be purchased separately.	\$480.00	\$480.00
	1 ea	XP-INSTALLATION TABLETOP Alto-Shaam Prodigi Factory Authorized Installation Program, for Table-top Units, (per unit ) ((NET) NO FURTHER DISCOUNTS APPLY) (NOTE: Includes travel within 100 miles (200 miles round-trip) of installer. Additional charges apply outside the 100 mile limit. Contact your local factory-authorized service agent for details and prices on other Alto-Shaam equipment)	\$1,301.00	\$1,301.00



Item	Qty	Description	Sell	Sell Total
1 ea		<p>Installation Program includes:</p> <ol style="list-style-type: none"> <li>1. Travel within 100 miles (200 miles round-trip) of installer</li> <li>2. Professionally reviewed and managed installation process</li> <li>3. Assembly of purchased equipment</li> <li>4. Assembly of any accessories</li> <li>5. Placement and leveling of unit</li> <li>6. Connection to existing utilities within three feet of unit</li> <li>7. mechanical startup to ensure proper function</li> </ol> <p>(Note: Installation of units outside of the 100-mile radius will require additional travel charges to be payable by the customer. To verify coverage within 100 miles, please submit a service agent inquiry to travel-quotes@alto-shaam.com. Please include site name &amp; address in your email inquiry.)</p> <p>Installation Program does not include:</p> <ol style="list-style-type: none"> <li>1. Delivery to end user location</li> <li>2. Unit must be within five feet of and have a clear and unobstructed path to final destination</li> <li>3. Special licensing or permits</li> <li>4. Overtime travel or labor</li> <li>5. Removal of packing material</li> <li>6. Removal and scrapping of old unit</li> <li>7. Installation kit</li> <li>8. Pre-installation site survey</li> </ol>		
1 ea		Specify gas type		
1 ea		TURBO without Smoker, standard		
1 ea		120v/60/1-ph, 6.8 amps, .84kW, 12 AWG, NO cord or plug		
1 kt		5026980 Installation Kit, for gas combi ovens, Copper, rated up to 20.0 amps, per oven ((NET) NO FURTHER DISCOUNTS APPLY) (Note: Required to meet NYC requirements)	\$1,073.00	\$1,073.00
1 ea		Wifi, standard		
1 ea		Single		
1 ea		5037355 QT11+CR Water Filter System for single combi or Converge ovens, (1) CTO-Q10 activated carbon cartidge, reduces chlorine & sediment, (1) CTOS-QCR catalytic carbon cartridge, reduces chloramine; outlet pressure gauge, water-shut off valve, bypass valve; 3/4" inlet, 3/4" outlet; NOTE: hardware for mounting to a wall and connection hoses are not included; ((NET) NO FURTHER DISCOUNTS APPLY)	\$448.00	\$448.00
1 ea		Water Filter System Field Install Program, single or stacked ovens ((NET) NO FURTHER DISCOUNTS APPLY)	\$181.00	\$181.00
1 ea		NOTE: Factory Authorized Installation Program (above) MUST be selected for water filtration field install option to become available		
1 ea		HO-36870 HO-36870 Hose, 3/4" NPT, 6' long; NOTE: installation kits only contain 2 hoses, a third inlet hose is required to connect the	\$97.00	\$97.00

Item	Qty	Description	Sell	Sell Total
		water filtration system		
	1 ea	Removable "T" style temperature probe, standard		
			<b>Extended Total:</b>	<b>\$23,566.00</b>
004.A. R	-1 ea	<b>MULTI-COOK OVEN</b>	\$27,067.00	\$-27,067.00
		Alto-Shaam VMC-F4G Vector® F Series Multi-Cook Oven, gas, (4) individually controlled cooking chambers, holds (8) half-size sheet pans (4) full sized sheet pans, programmable touch screen controls with Structured Air Technology®, double pane glass door, interior LED cavity lighting, includes: (1) wire rack & (2) jet plates per cooking chamber, USB port, stainless steel construction, cULus, UL EPH Classified		
	-1 ea	Deluxe Controls – Touch screen user interface with customizable home screen, programmable recipes, unlimited cook stages, recipe management, service diagnostics, and reporting on screen; enables access to ChefLinc™ remote oven management system to monitor ovens, view reports and push/pull recipes and oven settings via Wi-Fi or Ethernet connectivity	\$1,778.00	\$-1,778.00
	-2 ea	5016820 Removable, single-point, quick-connect core temperature probe (2 required)	\$366.00	\$-732.00
	-4 ea	5032534 Grease Kit, internal filter (one kit required per cavity)	\$197.00	\$-788.00
			<b>Extended Total:</b>	<b>\$-30,365.00</b>
004.A	2 ea	<b>MULTI-COOK OVEN</b>	\$12,043.00	\$24,086.00
		Alto-Shaam VMC-H3H Vector® H Series Multi-Cook Oven, electric, (3) individually controlled cooking chambers, holds (3) half-size sheet pans or (3) full-size hotel pans, programmable touch screen controls with Structured Air Technology®, double pane glass door, interior LED cavity lighting, ventless catalytic converter, includes: (1) wire rack & (2) jet plates per cooking chamber, USB port, stainless steel construction, 4" adjustable legs, cULus, UL EPH Classified, Made in USA		
		<b>Note: Vector units to go over combi on custom stand provided by others</b>		
	2 ea	NOTE: Subject to Manufacturer's Terms & Conditions. See Documents Section		
	2 ea	One year parts and labor warranty, standard		
	2 ea	208-240v/60/3-ph, 7.9-10.3 kW, 22.0-25.0 amps, NEMA 15-30		
	2 ea	Deluxe Controls – Touch screen user interface with customizable home screen, programmable recipes, unlimited cook stages, recipe management, service diagnostics, and reporting on screen; enables access to ChefLinc™ remote oven management system to monitor ovens, view reports and push/pull recipes and oven settings via Wi-Fi or Ethernet connectivity	\$1,919.00	\$3,838.00
	2 ea	Wifi, standard		



Item	Qty	Description	Sell	Sell Total
	2 ea	Right-hand hinged door, standard		
	2 ea	Seismic Leg Package, 6", for VMC-H Series	\$299.00	\$598.00
	6 kt	5027119 Grease Filter Kit, for Vector H/HH models (Note: one kit required per chamber)	\$164.00	\$984.00
			<b>Extended Total:</b>	<b>\$29,506.00</b>
004.B. R	-1 ea	<b>WATER FILTRATION SYSTEM, FOR STEAM EQUIPMENT</b>  Alto-Shaam 5037355 QT11+CR Water Filter System for single combi or Converge ovens, (1) CTO-Q10 activated carbon cartridge, reduces chlorine & sediment, (1) CTOS-QCR catalytic carbon cartridge, reduces chloramine; outlet pressure gauge, water-shut off valve, bybass valve; 3/4" inlet, 3/4" outlet; NOTE: hardware for mounting to a wall and connection hoses are not included; ((NET) NO FURTHER DISCOUNTS APPLY)	\$415.00	\$-415.00
			<b>Extended Total:</b>	<b>\$-415.00</b>
011.R	-1 ea	<b>HEATED HOLDING CABINET</b>   Alto-Shaam 1200-UP Halo Heat® Low Temperature Holding Cabinet, double compartment, on/off simple controller with adjustable thermostats, indicator light, (2) sets of chrome plated universal side rails, (4) sets of pan slides, (16) 20" x 12" x 2-1/2" full size pan capacity, heavy stainless steel exterior, 5" casters; 2 rigid, 2 swivel with brakes, EcoSmart®, cULus, UL EPH Classified, CE, IPX4, TUV NORD, EAC, ENERGY STAR®	\$5,279.00	\$-5,279.00
	-1 ea	Deluxe control, LED display, with probe	\$1,009.00	\$-1,009.00
	-2 ea	Pass-thru design, price per cavity (2 required)(not E-Star certified)	\$627.00	\$-1,254.00
	-2 ea	Window door, hinged on right, per door (factory installed)	\$358.00	\$-716.00
	-2 ea	Window door, hinged on left, per door (factory installed)	\$358.00	\$-716.00
	-1 ea	SH-23738 Shelf, stainless steel	\$89.00	\$-89.00
	-1 ea	5014448 Drip Pan, with drain, stainless steel, 1-11/16" (43mm)	\$248.00	\$-248.00
	-1 ea	5011149 Leg Set, 6" high (set of 4) (cannot be used with bumper)	\$272.00	\$-272.00
			<b>Extended Total:</b>	<b>\$-9,583.00</b>
011	1 ea	<b>HEATED HOLDING CABINET</b>   Alto-Shaam 1200-UP Halo Heat® Low Temperature Holding Cabinet, double compartment, on/off simple controller with adjustable thermostats, indicator light, (2) sets of chrome plated universal side rails, (4) sets of pan slides, (16) 20" x 12" x 2-1/2" full size pan capacity, heavy stainless steel exterior, 5" casters; 2 rigid, 2 swivel with brakes, EcoSmart®, cULus, UL EPH Classified, CE, IPX4, TUV NORD, EAC, ENERGY STAR®	\$5,698.00	\$5,698.00
	1 ea	NOTE: Subject to Manufacturer's Terms & Conditions. See Documents Section		
	1 ea	12 month extended warranty to begin at the end of std. warranty & continue for 12 additional months (net)	\$320.00	\$320.00

Item	Qty	Description	Sell	Sell Total
	1 ea	208-240v/50/60/1-ph, 7.0-8.0 amps, 2000W, (low-wattage) 8' cord, NEMA 6-15P		
	1 ea	Simple control, on/off, adjustable thermostat		
	2 ea	Pass-thru design, price per cavity (2 required)(not E-Star certified)	\$677.00	\$1,354.00
	2 ea	Window door, hinged on right, per door (factory installed)	\$386.00	\$772.00
	2 ea	Window door, hinged on left, per door (factory installed)	\$386.00	\$772.00
	1 ea	Doors hinged on same sides	\$236.00	\$236.00
	8 ea	SR-24447 Universal Pan Slide, chrome plated (2 pieces required)	\$40.00	\$320.00
		<b>Extended Total:</b>		<b>\$9,472.00</b>
004.C	1 ea	<b>WORK TABLE</b> Emjac Industries CUSTOM Work table, as per plans, specification and approved drawings.	\$2,590.95	\$2,590.95
		<b>Extended Total:</b>		<b>\$2,590.95</b>
025.A.	1 ea	<b>SIDE SPLASH</b>  Advance Tabco TA-30 Side Splash, 1-1/2" high (each)	\$66.96	\$66.96
1		<b>Extended Total:</b>		<b>\$66.96</b>
025.A.	1 ea	<b>POT RACK HOOK</b>  Advance Tabco TA-89A Pot Hooks, plated, single sided (package of 4)	\$43.01	\$43.01
2		<b>Extended Total:</b>		<b>\$43.01</b>
025.B.	1 ea	<b>SIDE SPLASH</b>  Advance Tabco TA-30 Side Splash, 1-1/2" high (each)	\$66.96	\$66.96
1		<b>Extended Total:</b>		<b>\$66.96</b>
025.B.	1 ea	<b>POT RACK HOOK</b>  Advance Tabco TA-89A Pot Hooks, plated, single sided (package of 4)	\$43.01	\$43.01
2		<b>Extended Total:</b>		<b>\$43.01</b>
027.R	-1 ea	<b>MILLWORK CONDIMENT COUNTER</b> Emjac Industries CUSTOM Millwork condiment counter	\$9,193.00	-\$9,193.00
		<b>Extended Total:</b>		<b>-\$9,193.00</b>
030.B.	3 ea	<b>POT RACK HOOK</b>  Advance Tabco TA-89A Pot Hooks, plated, single sided (package of 4)	\$43.01	\$129.03
1		<b>Extended Total:</b>		<b>\$129.03</b>

Item	Qty	Description	Sell	Sell Total
030.B. 2	2 ea	<b>SIDE SPLASH</b>  Advance Tabco TA-30 Side Splash, 1-1/2" high (each)	\$66.96	\$133.92
			<b>Extended Total:</b>	<b>\$133.92</b>
044.1	3 ea	<b>CONDIMENT JAR</b> Cal-Mil 22107-55 Storage Jar/Bin, 4"W x 4"D x 4"H, stainless steel (lids sold separately)	\$55.60	\$166.80
			<b>Extended Total:</b>	<b>\$166.80</b>
Z...	1 ea	<b>FREIGHT</b> FREIGHT CHARGES FRT Estimated freight charges	\$575.00	\$575.00
			<b>Extended Total:</b>	<b>\$575.00</b>
			<b>Total</b>	<b>\$-8,893.36</b>

*A formal Change Order must be received within 45 days of approval of the above. This acceptance authorizes Baring Industries to proceed with the work described herein, and authorizes Baring Industries to collect payment for price shown.  
Original contract terms and conditions apply unless otherwise noted.*

Acceptance: \_\_\_\_\_ Date: \_\_\_\_\_

Printed Name: \_\_\_\_\_

Project Grand Total: \$-8,893.36

04/29/2026

# Request For Change Order

To: Moss & Associates  
 Mathew Kane  
 6363 NW 6th Way  
 Fort Lauderdale, FL 33309

From: Baring Industries, Inc.  
 Gina Pagan  
 3249 SW 42nd Street  
 Fort Lauderdale, FL 33312-6810  
 (954)327-6700  
 954-327-6725 (Contact)

Project: 251061-FPHQ-RCO 2-Amerikooler PO  
 EPA Technology Transitions rule  
 revision

Thank you for the opportunity and we look forward to working  
 with you in the near future.

Item	Qty	Description	Sell	Sell Total
001.B	1 ea	<b>REFRIGERANT A2L ACCESSORIES</b> AmeriKooler CUSTOM A 2L Refrigerant Component required per EPA's Technology Transitions Rule: (1)ASSY-A2L SOLENOID SHUT-OFF VLV 3/8 LIQ-1 (now part 29338301), (1)ASSY-A2L CHECK SHUT-OFF VALVE 5/8 SUC (now part 29308802)	\$990.00	\$990.00
			<b>Extended Total:</b>	<b>\$990.00</b>
			Merchandise	\$990.00
			Tax 7%	\$69.30
			<b>Total</b>	<b>\$1,059.30</b>

*A formal Change Order must be received within 45 days of approval of the above. This acceptance authorizes Baring Industries to proceed with the work described herein, and authorizes Baring Industries to collect payment for price shown.*

*Original contract terms and conditions apply unless otherwise noted.*

Acceptance: \_\_\_\_\_ Date: \_\_\_\_\_

Printed Name: \_\_\_\_\_

Project Grand Total: \$1,059.30



## Proposal - #5 Kitchen Equipment Changes

---

Date: 5/4/26  
To: Matthew Kane; Moss  
Project name: FLPD – HQ LVL 2 Kitchen  
Project address: 1300 W Broward Blvd, Fort Lauderdale, FL, 3312  
Project number: 26-021

This proposal is provided at the request of Ownership to accommodate revised kitchen equipment power requirements, information was provided by MOSS and Baring subcontractor, see below email thread back up for reference. Scope includes modification of existing electrical provisions and the addition of new power provisions to support updated equipment needs.

Revising existing provisions from a 208V, 1-phase, 20A junction box at +24" AFF to one (1) 208V, 3-phase, 30A receptacle (NEMA 15-30R) at +50" AFF. Additionally, one (1) new 208V, 3-phase, 30A receptacle (NEMA 15-30R) at +50" AFF is being provided. Further revisions include modification of an existing 208V, 1-phase, 15A junction box at +50" AFF to a 120V, 1-phase, 20A junction box at +24" AFF.

These changes required reconfiguration and/or replacement of existing conductors, installation of additional conductors, and adjustments to circuit breaker sizes and wiring devices. Previously procured wiring devices cannot be returned as they have already been delivered to the project site. Any remaining materials will be turned over to Ownership as attic stock.

### **Our proposal includes:**

- Demolition of drywall
- Demolition of existing power provisions
- Removal of existing conductors
- Rewiring of conductors per new power requirements
- Addition of provisions for added equipment
- Associated circuit breaker removal at electrical panel
- Associated circuit breaker installation and wire trim at electrical panel
- Associated wiring device installation and wire trim at equipment locations
- Tablet/Computer with software and services.
- Telephone and service
- Delivery & Pickup of material from TEC warehouse to jobsite
- Sales Tax
- Clean up
- Travel Time/ Offsite Parking

### **Our proposal excludes:**

- Reinstallation/ replacement of ceiling tile or access panels



**SERVICE GROUP**

## **Proposal - #5 Kitchen Equipment Changes**

---

- Layout, elevation and Installation of equipment by others.
- Demolition, relocation, or removal of existing completed millwork, furniture, and equipment.
- Repair, protection, or removal fo furniture.
- Repairing, patching, and/or painting of finishing of any surfaces impacted by the conduit or box required to complete this work.
- Concrete coring, drilling, cutting and/or backfilling.
- Any low voltage cabling, terminations, or free wire cabling support.
- Specialty or custom materials outside of this proposal to be provided by others.
- Any waterproofing.
- Accelerated schedule requirements.
- After hours and/or overtime hours.
- Permit fees.
- Remedial work or repair work necessary due to these changes is to be performed by others, Any unforeseen conditions, code requirements, or field conflicts discovered after work begins that impact labor or material shall be addressed via additional cost and time adjustment.

**Clarifications:**

- Bid price is subject to change after 30 days from this bid date
- Any existing conditions, which are not reflected in the plans, but affects the cost of the work, shall be considered an extra to this scope of work.

**Price:** **\$5,162.55**

---

Sincerely,

Brandon A Rodriguez, TEC Service Group

**Project Name:** PJ -TECSG  
**Project Number:** PJ -TECSG  
**Page Number:** 1  
**Change Order #:** FLPD - 05  
**Change Order Date:** 5/4/2026

---

**Summary**

---

**MATERIAL**

General Materials		279.88	
ANIXTER SWITCHGEAR		1,772.99	
Material Tax	(@ 7.000 %)	143.70	
		<hr/>	
<b>Material Total</b>			<b>2,196.57</b>

**LABOR**

SERVICE TECHNICIAN	(16.00 Hrs @ \$95.00)	1,520.00	
SCHEDULER	(0.32 Hrs @ \$75.00)	24.00	
CLEAN UP	(8.00 Hrs @ \$52.00)	416.00	
ESTIMATING	(2.00 Hrs @ \$55.00)	110.00	
		<hr/>	
<b>Total Labor</b>			<b>2,070.00</b>

<b>TOTAL MATERIAL, LABOR &amp; EQUIPMENT</b>		<hr/>	<b>4,266.57</b>
--	--	-------	-----------------

<b>Final Amount</b>		<hr/>	<b>\$5,162.55</b>
---------------------	--	-------	-------------------

**CLIENT ACCEPTANCE**

<b>Name:</b>	<hr/>
<b>Date:</b>	<hr/>
<b>Signature:</b>	<hr/>

I hereby accept this quotation and authorize the contractor to complete the above described work.

**Project Name:** PJ-TECSG  
**Project Number:** PJ-TECSG  
**Page Number:** 2  
**Change Order #:** FLPD - 05  
**Change Order Date:** 5/4/2026

---

**Itemized Breakdown**

---

Drawing	Material(\$)	Labor Hrs
K1-7	279.90	9.79
HQ-E5-2-14	0.00	3.00
<b>Total</b>	<b>279.90</b>	<b>12.79</b>

**K1-7**

Description	Qty	Net Price U	Total Mat.	Labor U	Total Hrs.
FIRESTOP COMPOUND CAULK (1) PIPE	1	1.00 E	1.00	0.06 E	0.06
3/4" CONDUIT - EMT	10	154.78 C	15.48	4.40 C	0.44
3/4" COUPLING COMP STL - EMT	0	424.55 C	0.00	0.00 C	0.00
3/4" CONN COMP STL INSUL - EMT	4	471.66 C	18.87	15.63 C	0.63
1/2 OR 3/4" SNAP CLOSE CLIP - SIDE MNT TO MTL STUD SUPPORT	3	178.59 C	5.36	9.00 C	0.27
1/2 OR 3/4" SNAP CLOSE CLIP ON ANGLE BRKT	2	133.36 C	2.67	10.25 C	0.20
4x 1 1/2" SQ BOX COMB KO	1	1,469.00 C	14.69	28.75 C	0.29
4" SQ 1G PLSTR RING 5/8" RISE	1	937.62 C	9.38	3.13 C	0.03
#8x 1/2 P/H SELF-TAP SCREW	6	8.40 C	0.50	3.00 C	0.18
#10 THHN BLACK	343	393.32 M	134.91	7.06 M	2.42
#10 THHN RED	14	393.32 M	5.51	7.06 M	0.10
#10 THHN WHITE	14	393.32 M	5.51	7.06 M	0.10
#10 THHN GREEN	131	393.32 M	51.52	7.06 M	0.92
WIRE CONN RED	7	19.64 C	1.37	4.00 C	0.28
1/8" POLYTWINE	137	11.94 M	1.64	3.75 M	0.51
2G 1x 2.109" DIAM REC PLATE - PLASTIC IVY	1	1,148.80 C	11.49	4.75 C	0.05
DRYWALL DEMO	1	0.00 E	0.00	1.30 E	1.30
WIRE REMOVAL FROM EXISTING PROVISIONS	2	0.00 E	0.00	1.00 E	2.00
<b>Totals</b>	<b>678</b>		<b>279.88</b>		<b>9.78</b>

**HQ-E5-2-14**

Description	Qty	Net Price U	Total Mat.	Labor U	Total Hrs.
BREAKER INSTALLATION AND WIRE TRIM	3	0.00 E	0.00	1.00 E	3.00
<b>Totals</b>	<b>3</b>		<b>0.00</b>		<b>3.00</b>

## Brandon Rodriguez

---

**From:** Hung, Adrian <adrian.hung@anixter.com>  
**Sent:** Friday, May 1, 2026 2:23 PM  
**To:** Hung, Adrian  
**Subject:** Bid SE45624758

## Quotation

**#3863 MIAMI APS**  
**ANIXTER INC.**  
**11420 NORTHWEST 122ND ST**  
**SUITE 100**  
**MEDLEY FL 33178**  
**305-805-3830 Fax 305-805-3869**

SE45624758  
14:22:46EST 05/01/26

All sales are subject to Anixter Inc.'s Terms & Conditions of Sale found at [https://www.anixter.com/en\\_us/resources/terms-of-sale.html](https://www.anixter.com/en_us/resources/terms-of-sale.html) PRODUCT SAFETY DATA SHEETS ON SAME WEB SITE.

**Sold To:48923**  
THUNDER ELECTRICAL CONTRACTORS  
INC  
7035 F SW 47TH STREET STE F  
MIAMI, FL 33155  
305-669-1776 Fax 305-669-1710

**Ship To:1168251**  
FT LAUDERALE POLICE HQ  
1300 W BROWARD BLVD  
FORT LAUDERDALE, FL 33312-1699  
305-669-1776 Fax 305-669-1710

Ordered By	Ship Via	Quote Date			
.		05/01/26			
Writer	Freight Terms/FOB	Expiration Date			
Adrian Hung	No	05/11/26			
Salesperson	Terms	FOB			
Adrian Hung	NET 10TH PROX 1.5% SC 25				
Special Instructions					
Quantity	Product Description	FD	Unit Price	UM	Net Amount
2ea	LEV 8430 RECEPTACLE 15-30R		49.023	ea	98.05
2ea	LEV 2723 LKG CONN L15-30R		31.978	ea	63.96
2ea	C-H BAB3030HS BAB 3P 30A BRKR MAX		734.794	ea	1469.59
1ea	C-H BAB1020S BAB BRKR 1P 20A MAX		141.390	ea	141.39
Wesco may assess storage and transportation fees if you do not take or accept delivery within 90 days of product availability. Wesco may also update this quote or above pricing due to duties, freight, tariffs, supplier pricing, surcharges, or exchange rate fluctuations. BY ACCEPTING THIS QUOTE, YOU AGREE THAT THE TERMS					

AND CONDITIONS OF SALE PUBLISHED AT <a href="http://www.wesco.com/termsOfSale">www.wesco.com/termsOfSale</a> ARE EXPRESSLY INCORPORATED INTO AND SHALL GOVERN THIS TRANSACTION.		
Total Weight 5.3 lbs	<b>Subtotal</b>	1772.99
THIS IS A QUOTATION	S&H	0.00
Prices are firm until 05/11/26, subject to change without notice after 05/11/26.	<b>Tax</b>	<b>124.11</b>
SALES TAX IS AN ESTIMATE!S&H IS AN ESTIMATE!	<b>Total</b>	<b>1897.10</b>

## Brandon Rodriguez

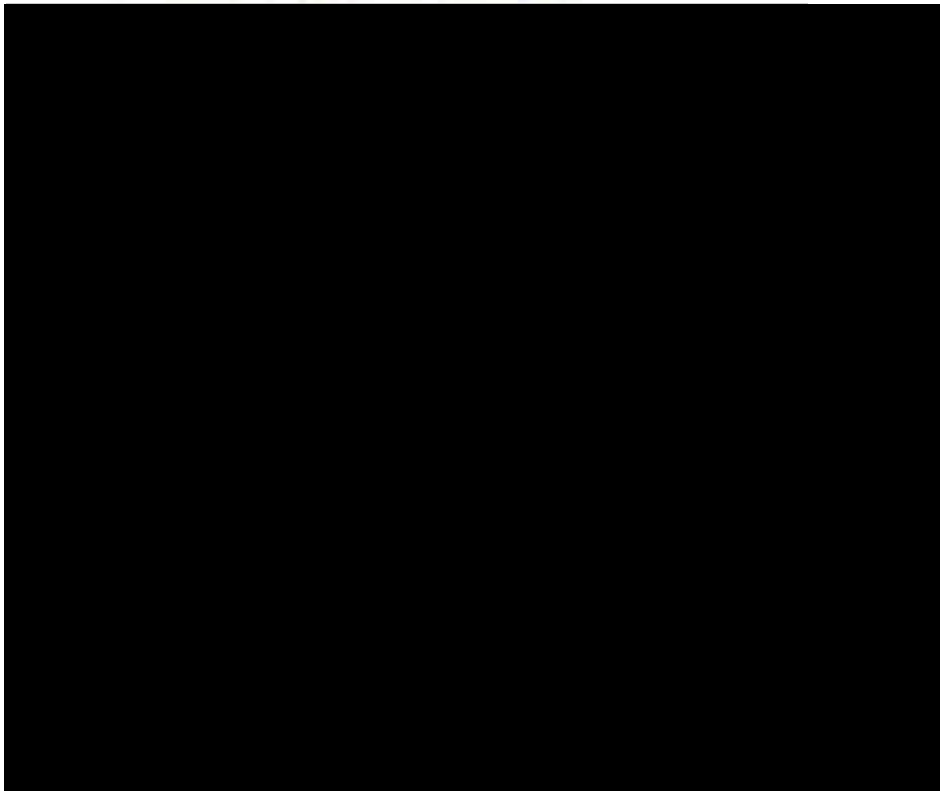
---

**From:** William Toledo <william.toledo@baring.com>  
**Sent:** Wednesday, April 22, 2026 3:46 PM  
**To:** Matthew Kane; Brandon Rodriguez; Pedro J. Hernandez  
**Cc:** Tiago Lima; Andy McCright; John-James Yancey; James Pope  
**Subject:** RE: 251061\_RCO\_1\_Cut\_Book\_Submittal\_changes\_\_and\_\_scope\_review\_Rev\_2

Attached layout.

#4 is now a 120V unit on a single 20Amp Shunt Trip Breaker

#4A is now qty 2 – Each to have a 15-30R – Each unit pulls 22amps. And requires a 30 Amp Shunt Trip breaker.



Regards,

William Toledo | Project Manager

**BARING INDUSTRIES, INC.**

3249 SW 42 Street

Fort Lauderdale, Florida 33312

O: (954) 327.6767 (Direct) | M: (954) 552.2265

Email: [William.Toledo@baring.com](mailto:William.Toledo@baring.com)

---

**From:** Matthew Kane <mkane@moss.com>

**Sent:** Wednesday, April 22, 2026 9:30 AM

**To:** Brandon Rodriguez <brandon@thunder-electric.com>; Pedro <pedro@thunder-electric.com>; William Toledo <william.toledo@baring.com>

**Cc:** Tiago Lima <tlima@moss.com>; Andy McCright <amccright@moss.com>; John-James Yancey <jjyancey@moss.com>; James Pope <jpope@moss.com>

**Subject:** FW: 251061\_RCO\_1\_Cut\_Book\_Submittal\_changes\_\_and\_\_scope\_review\_Rev\_2

Brandon, can you get us a price asap for the change to double multi oven? @William Toledo can you confirm below and mark a drawing for location of boxes

Combi Oven (Bottom)

1 ea 120v/60/1-ph, 6.8 amps, .84kW, 12 AWG, NO cord or plug

(2) Multi Oven (Top)

2 ea 208-240v/60/3-ph, 7.9-10.3 kW, 22.0-25.0 amps, NEMA 15-30

Matthew Kane  
Project Manager

**Moss**

Cell: 321.427.3500

[moss.com](http://moss.com)

---

**From:** Ronald Stein <[RStein@fortlauderdale.gov](mailto:RStein@fortlauderdale.gov)>

**Sent:** Wednesday, April 22, 2026 9:10 AM

**To:** Matthew Kane <[mkane@moss.com](mailto:mkane@moss.com)>

**Subject:** FW: 251061\_RCO\_1\_Cut\_Book\_Submittal\_changes\_\_and\_\_scope\_review\_Rev\_2

**CAUTION: This email originated from outside of Moss**

Do not click links or open attachments unless you can confirm the sender and know the content is safe.

Be careful of any attachments or links that ask for your password.

Matt

Please provide a formal PCI for this credit along with any MEP's that need to be added.

Thanks

Ron

**Ronald Stein**

**Sr. Project Manager**

101 NE 3<sup>rd</sup> Ave, Suite 2100 | Fort Lauderdale FL 33301

City of Fort Lauderdale

C: (954) 531-2395 | E: [RStein@fortlauderdale.gov](mailto:RStein@fortlauderdale.gov)



---

**From:** Matthew Kane <[mkane@moss.com](mailto:mkane@moss.com)>

**Sent:** Tuesday, April 21, 2026 10:22 AM

**To:** Ronald Stein <[RStein@fortlauderdale.gov](mailto:RStein@fortlauderdale.gov)>

**Cc:** WTOLEDO\_CU <[william.toledo@baring.com](mailto:william.toledo@baring.com)>; Theodore Barber <[tbarber@barberassoc.com](mailto:tbarber@barberassoc.com)>; Siegel, Evan <[evan.siegel@aecom.com](mailto:evan.siegel@aecom.com)>

**Subject:** [EXTERNAL:CAUTION!] - FW: 251061\_RCO\_1\_Cut\_Book\_Submittal\_changes\_\_and\_\_scope\_review\_Rev\_2

Mimecast Attachment Protection has deemed this file to be safe, but always exercise caution when opening files.

**[::CAUTION!:] This email originated from *outside* The City of Fort Lauderdale. Do Not Reply, click links, or open attachments from an unknown or suspicious origin. Confirm the email address is from an expected source before taking action. Report any suspicious emails to [spamadmin@fortlauderdale.gov](mailto:spamadmin@fortlauderdale.gov)**

---

Ron, please see attached revised kitchen RCO for the oven changes resulting in a net credit of (\$8,893.36). In speaking with Will from Baring (CC'd), Ted worked closely with the manufacturer rep to maximize the credits to offset cost of the added electrical and accessories.

Let us know if you have any questions.

Matthew Kane  
Project Manager  
**Moss**  
Cell: 321.427.3500  
[moss.com](http://moss.com)

