



Event # 209-4

Name: Design Build Services for G. T. Lohmeyer WWTP Odor Control

Description: The City of Fort Lauderdale, Florida (City) is seeking bids from qualified bidders, hereinafter referred to as the Contractor, to provide competitive proposals from a Design-Build Firm, responsible for the design, permitting, and construction under one contract for the renovation of the Sludge Holding Tank Building and Pretreatment Building and replacement of odor control equipment on the Sludge Holding Tank Building and Pretreatment Building exterior at the George T. Lohmeyer Wastewater Treatment Plant to fulfill the intent of the Project as described in the Scope of Work, Design Criteria and all supporting documents.

Buyer: LEMIRE, MICHELLE

Status: Pending Award

Event Type: RFP

Currency: USD

Sealed Bid: Yes

Respond To All Lines: Yes

Q & A Allowed: Yes

Number Of Amendments: 4

Display Bid Tabulation: Display When Event Closed For Bidding Or Canceled

Event Dates

Preview:

Q & A Open: 12/26/2023 02:00:00 PM

Open: 12/26/2023 02:00:00 PM

Q & A Close: 03/15/2024 02:00:00 PM

Close: 05/03/2024 02:00:00 PM

Dispute Close:

Questions

Question	Response Type	Attachment
Did you fill out and attach all required documents?	Yes No	Event 209 - Required Forms.pdf

Attachments

Name	Description	Attachment
Event 209 - Solicitation Document	Event 209 - Solicitation Document	Event 209 - GTL Odor Control Improvements.pdf
Event 209 - Sample Agreement	Event 209 - Sample Agreement	Event 209 - Sample Agreement.pdf

Event # 209-4: Design Build Services for G. T. Lohmeyer WWTP Odor Control

Name	Description	Attachment
Event 209 - Secured Plans Request Form	Event 209 - Secured Plans Request Form	Event 209 - Plans Request Form.pdf
Addendum No. 1	Addendum No. 1	Event 209 - Addendum No. 1.pdf
Event 209 - Addendum No. 2	Event 209 - Addendum No. 2	Event 209 - Addendum No. 2.pdf
Event 209 - Addendum No. 3	Event 209 - Addendum No. 3	Addendum No. 3.pdf
Surety Bond Template	Surety Bond Template	Surety Bond Template.pdf
Event 209 - Addendum No. 4	Event 209 - Addendum No. 4	Event 209 - Addendum No. 4.pdf
CodeMaster LED Sealed Lights Specifications	CodeMaster LED Sealed Lights Specifications	CodeMaster LED Sealed Lights Specifications.pdf

Commodity Codes

Commodity Code	Description
913-56	Construction, Utility/Underground Projects

Line Details

Line 1: GTL Odor Control

Description: GTL Odor Control

Item: GTL ODOR CONTROL GTL Odor Control

Commodity Code: 913-56 Construction, Utility/Underground Projects

Quantity: 1.0000 **Unit of Measure:** EA

Requested Delivery Date: 12/31/2025

Require Response: Yes

Price Breaks Allowed: No

Allow Alternate Responses: No

Add On Charges Allowed: No

Executive Summary Report

of

Event: 209-4 - Design Build Services for G. T. Lohmeyer WWTP Odor Control

Buyer: MICHELLE LEMIRE

Date Range: 12/26/2023 02:00:00 PM - 05/03/2024 02:00:00 PM

**All Suppliers 1
Responding:**

Suppliers Responding

Supplier	Contact	Phone Number	E Mail	City	State Or Province	Total Bid Amount	Total Awarded	Response Attachments Exist
AECOM Technical Services, Inc.	Juli Binaco	407 843-6552	juli.binaco@aecom.com	Orlando	FL	1.00	0.00	Yes

Event Lines And Responses

Item	Description	Unit of Measure	Quantity
GTL ODOR CONTROL-	GTL Odor Control	EA	1.0000

Responses

Supplier	Bid Quantity	Unit of Measure	Unit Price	Award Amount
AECOM Technical Services, Inc.	1.0000	EA	1.00000000	0.00

Header Questions And Responses

QUESTION

Did you fill out and attach all required documents?

continued...

Question Responses

Supplier	Response	Has Attachment
AECOM Technical Services, Inc.	Yes	Yes

Q And A

Supplier	Question	Answer
Trippensee Shaw, Inc.	Please provide the Pre-Bid list of attendees.	Please see attached sign in sheet from Pre-Proposal Conference.
AECOM Technical Services, Inc.	Appendix D - Can the City please provide the full set of electrical record drawings for the Facility? In the set provided, the electrical drawings skip from drawing E-49 to drawing E-59, amongst others. Single line diagrams for the entire facility	Refer to Addendum No. 1.
AECOM Technical Services, Inc.	It is our understanding that an updated single line for the entire facility has been prepared recently and request a copy of this drawing.	Refer to Addendum No. 1.
AECOM Technical Services, Inc.	What is the scope of work for the existing Air Conditioning and ventilation system for the Pre-treatment facility. Are the AC systems for the break room, locker rooms, etc. to remain?	All HVAC systems are to be replaced in the Pretreatment Building as part of this scope. This includes ductwork. No HVAC systems are to be replaced in the Sludge Holding Tank Building.
AECOM Technical Services, Inc.	Are there any AutoCAD files for the Facility that could be shared?	Refer to Addendum No. 1.
AECOM Technical Services, Inc.	Are there any temporary ventilation measures needed if the Pretreatment OC system is demolished, prior to the replacement system going online?	No temporary ventilation measures are required.
AECOM Technical Services, Inc.	Please provide an updated I/O list for PLC-1A and PLC 1B.	Refer to addendum No. 2.
AECOM Technical Services, Inc.	Please provide a system architecture detailing the fiber optic network.	Refer to addendum No. 2.

continued...

Supplier	Question	Answer
AECOM Technical Services, Inc.	Please provide a complete set of Pretreatment Building electrical drawings.	Missing drawings E-49 to E-58 were provided in the 100-E drawing set as part of Addendum No.1. Additional drawings can possibly be located. The 1980 Hazen Drawings were done in several separate projects, and one complete set does not exist.
AECOM Technical Services, Inc.	Please provide a set of VSPA Project contract drawings as a reference.	Refer to Addendum No. 1.
AECOM Technical Services, Inc.	Please provide a list of instruments that require replacement.	Refer to Addendum No. 1.
AECOM Technical Services, Inc.	Does the City have any data for the mothballed pre-treatment facility odor control system? Specifically, H2S readings from the OC system influent when the system was operational? Are there any H2S from inside pretreatment building?	Refer to Technical Memorandum provided in Addendum No.1. Proposers are also welcome to schedule a site visit and measure H2S.
AECOM Technical Services, Inc.	Can the plant operate with one sludge holding tank out of service? If so, for how long?	The plant can operate for 2-4 weeks at a time with one tank out of service depending on the time of year. Some recovery of the process may be necessary at that point using 2 tanks for 1-2 weeks before 1 tank mode is available again.
AECOM Technical Services, Inc.	Can the City provide any odor control permits that are on file with DEP?	There are no odor control permits on file with FDEP.
AECOM Technical Services, Inc.	Please provide information on what equipment or instruments require air from the replacement air system.	If this is in reference to the note on Drawing M-40 of the DCP drawings, this is demolition work only. The reference to "new, existing" is describing the system located immediately to the west of this demolish work currently in operation. Existing system is sufficient for current equipment needs at the LOX storage tank area. However, if the Design Build Firm's new equipment requires additional compressed air, the Design Build Firm is responsible for sizing and providing.
AECOM Technical Services, Inc.	RFP states to match the manufacturer, mode, and style of adjacent Oxygen Production Building. Can the City provide the manufacturer or specification on the VSPA building roof?	Refer to approved shop drawings provided in addendum No. 1.
AECOM Technical Services, Inc.	We request extension of RFP #209 bid date to April 30,2024. Although we are working hard to comply with the current Bid Date of March 29, we believe that it is in City's best interest to grant this extension as detailed in the attached.	Refer to Addendum No. 2.

continued...

Supplier

Question

Answer

AECOM Technical Services, Inc.

Section 9.7 of the Sample Agreement calls for a Warranty Bond and is referenced as an Exhibit which was not provided. Please see attached question regarding this.

Refer to Addendum No. 3.

Design-Build Request for Proposals

RFP # 209

Design Build Services for G. T. Lohmeyer WWTP Odor Control Improvements

Pursuant to FL Stat Section 287.057

City of Fort Lauderdale



MICHELLE LEMIRE, PROCUREMENT ADMINISTRATOR
Telephone: (954) 828-6167 E-mail: mlemire@fortlauderdale.gov

SECTION 1 INTRODUCTION

1.1 Purpose

The City of Fort Lauderdale, FL (“City”) has issued this Request for Proposal (RFP) to solicit competitive proposals from one single entity (“Firm” or “Proposer” or “Design-Build Firm (DBF)”) responsible for the design, permitting, construction, testing and startup of G. T. Lohmeyer WWTP Odor Control Improvements. The work to be accomplished under this contract includes, but is not limited to; demolition, replacement of odor control equipment, roof and pipe replacement, exterior painting, interior painting, lighting replacement, flooring replacement, kitchen and locker room remodeling, addition of walkable aluminum covers for wastewater channels and basins, concrete repair, fiberglass ductwork, electrical design and construction of new unitized substations and motor control centers, including all other aspects of the Project to fulfill the intent of the Project as described in the Design Criteria Package and all supporting documents. Design-Build Firms which are interested in submitting proposals in response to this RFP shall comply with Section IV - Submittal Requirements.

The City will retain services within the scope of architecture or professional engineering and within the scope of construction contracting. The City will solicit proposals and establish a competitive selection process in accordance with City of Fort Lauderdale [Code of Ordinances Section 2-181\(f\)\(6\)](#) to procure the services of a qualified DBF.

The Design-Criteria Professional, including their sub-consultants, are not eligible to render design-build services for this solicitation. Pursuant to [Florida Statutes 287.055 \(9\) \(b\)](#), “A design criteria professional who has been selected to prepare the design criteria package is not eligible to render services under a design-build contract executed pursuant to the design criteria package.” The City reserves the right to disqualify any proposal from a team which includes any sub-consultant and/or individual who has played a substantial role in the development of the design criteria package or whose involvement with the design-build team would confer upon that team an unfair competitive advantage because of such sub-consultant’s or member’s prior involvement in the project.

1.2 Online strategic sourcing platform

The City uses the City’s online strategic sourcing platform to administer the competitive solicitation process, including but not limited to soliciting responses, issuing addenda, posting results and issuing notification of an intended decision. Proposers are strongly encouraged to read the various vendor guides and tutorials available in the City’s online strategic sourcing platform well in advance of their intention of submitting a response to ensure familiarity with the use of the City’s online strategic sourcing platform. The City shall not be responsible for a proposer’s inability to submit a response by the submission deadline date and time for any reason, including issues arising from the use of the City’s online strategic sourcing platform. There is no charge to register and download the RFP from the City’s online

strategic sourcing platform and to participate in the solicitation, nor will any fees be charged to the awarded DBF.

It is the sole responsibility of the proposer to ensure that its bid is submitted electronically through the City's online strategic sourcing platform no later than the time and date specified in this solicitation. **PAPER PROPOSAL SUBMITTALS WILL NOT BE ACCEPTED. PROPOSALS MUST BE SUBMITTED ELECTRONICALLY VIA** the City's online strategic sourcing platform. In the event of any conflict or discrepancy between bid price(s) submitted by bidder electronically into the City's online strategic sourcing platform Unit Price field(s), any other forms or attachments (whether part of the City's solicitation documents or documents created and uploaded by the bidder, or another section/field of the System, the online unit price(s) inputted electronically into the System by the bidder shall govern.

1.3 Electronic Bid Openings

This solicitation will be opened electronically via the City's online strategic sourcing platform at the date and time indicated in the solicitation. Once the Procurement Specialist opens the solicitation, the bid tabulations, (where applicable) may be viewed immediately on a computer, laptop, cell phone, or any other device with WiFi access.

Anyone requesting assistance or having further inquiry in this matter must contact the Procurement Specialist indicated on the solicitation, via the Question and Answer (Q&A) forum on the City's online strategic sourcing platform before the Last Day for Questions indicated in the Solicitation.

1.4 A pre-proposal meeting and site visit will be held on Wednesday, January 10 2024, at 10:00 a.m., local time,

**Location: GTL Wastewater Treatment Plant
1765 SE 18th St,
Fort Lauderdale, FL 33316.**

The City of Fort Lauderdale GTL WWTP is a secured facility and is exempt from the Public Records Law, pursuant to FL Statute Chapter 119.071. Interested parties **must** log on to the City's online strategic sourcing platform to access the City of Fort Lauderdale Plan & Specification Request Form **AND** must follow instructions contained therein.

Access to the pre-proposal meeting is only available to pre-approved plan holders originating from the City of Fort Lauderdale Plans Request Form. Non-approved attendees will not be allowed to participate in the pre-proposal meeting. To avoid any issues, Plans Custodians should provide proof of approval prior to the pre-proposal meeting.

While attendance is not mandatory, it is strongly suggested that all DBFs attend the pre-proposal conference. It will be the sole responsibility of the DBF to inspect the City's locations and become familiar with the scope of the City's requirements and

systems prior to submitting a proposal. No variation in price or conditions shall be permitted based upon a claim of ignorance. Submission of a proposal will be considered evidence that the proposer has familiarized himself with the nature and extent of the work, equipment, materials, and labor required.

It is recommended that DBFs have the solicitation document available at the pre-proposal meeting,

1.5 Point of Contact

City of Fort Lauderdale, Procurement Services Division

Attn: Michelle Lemire, Procurement Administrator

521 North East 4th Ave

Fort Lauderdale, FL 33301

Telephone: (954) 828-6167

E-mail: mlemire@fortlauderdale.gov

1.6 Compliance and Legal Conditions

In order to comply fully with the requirements of the City's Code of Ordinances below and Florida Statutes 287.055, the following procedures shall be followed in selecting firms to provide design-build services and in negotiating design-build contracts.

It will be the sole responsibility of the proposer to familiarize themselves with the following ordinances and statutes:

- a) [City of Fort Lauderdale Ordinance Section 2-181\(f\)\(6\) – Design/build contracts](#)
- b) [Florida Statutes 287.055](#) – Acquisition of professional architectural, engineering, landscape architectural, or surveying and mapping services; definitions; procedures; contingent fees prohibited; penalties.
- c) [Florida Statutes 287.055 \(9\)](#) Applicability to Design-Build Contracts

1.7 Concerning Sub-Contractors, Suppliers, and Others

The amount of work that is sublet by the Bidder shall be limited by the condition that the Bidder shall, with his own organization, perform at least forty percent (40%) of the total dollar amount of the Work to be performed under the Agreement.

1.8 Personal Investigation

Proposers shall satisfy themselves by personal investigation and by such other means as they may think necessary or desirable, as to the conditions affecting the proposed work and the cost. No information derived from maps, plans, specifications, or from the Engineer, City Manager, or their assistants shall relieve the DBF from any risk or from fulfilling all terms of the contract.

1.9 Design Criteria Package

In order to obtain plans for the project, log into the City's online strategic sourcing platform, complete a City of Fort Lauderdale Plans Request Form, and submit it to the City in accordance with instructions contained therein.

Access to the site visit (if any) is only available to pre-approved plan-holders originating from the City of Fort Lauderdale Plans Request Form. Non-approved attendees will not be allowed to participate in the site visit, if any. To avoid any issues, Plans Custodians should bring proof of approval to the site visit.

Pursuant to Subsection 119.071(3)(b), Florida Statutes (2022), building plans, blueprints, schematic drawings, and diagrams, including draft, preliminary, and final formats, which depict the internal layout and structural elements of the facility/location (collectively "Plans") are exempt from public inspection and copying except to a licensed architect, engineer, or contractor who is performing work on or related to the project. **The entities and persons receiving the Plans shall maintain the exempt status of the Plans.**

1.10 Audit of Contractor's Records

Upon execution of the Contract, the City reserves the right to conduct any necessary audit of the Contractor's records. Such an audit, or audits, may be conducted by the City or its representatives at any time prior to final payment, or thereafter, for a period up to three (3) years. The City may also require submittal of the records from either the Contractor, the Sub-contractor, or both. For the purpose of this Section, records shall include all books of account, supporting documents and papers deemed necessary by the City to assure compliance with the contract provisions.

Failure of the Contractor or Subcontractor to comply with these requirements may result in disqualification or suspension from bidding for future contracts or disapproval as a Sub-contractor at the option of the City.

The Contractor shall assure that each of its Sub-contractors will provide access to its records pertaining to the project upon request by the City.

1.11 Reservation for Award and Rejection of Bids

The City reserves the right to accept or reject any or all bids, part of bids, and to waive minor irregularities or variations to specifications contained in bids, and minor irregularities in the bidding process. The City also reserves the right to award the contract on a split order basis, lump sum basis, individual item basis, or such combination as shall best serve the interest of the City. The City reserves the right to make an award to the responsive and responsible bidder whose product or service meets the terms, conditions, and specifications of the ITB and whose bid is considered to best serve the City's interest. In determining the responsiveness of the offer and the responsibility of the Bidder, the following shall be considered when applicable: the ability, capacity and skill of the Bidder to perform as required; whether the Bidder can perform promptly, or within the time specified, without delay or interference; the character, integrity, reputation, judgment, experience and efficiency of the Bidder; the quality of past performance by the Bidder; the previous

and existing compliance by the Bidder with related laws and ordinances; the sufficiency of the Bidder's financial resources; the availability, quality and adaptability of the Bidder's supplies or services to the required use; the ability of the Bidder to provide future maintenance, service or parts; the number and scope of conditions attached to the bid.

1.12 Lobbyist Ordinance

ALL PROPOSERS PLEASE NOTE: Any proposer submitting a response to this solicitation must comply, if applicable, with City of Fort Lauderdale Ordinance No. C-11-42 & Resolution No. 07-101, Lobbying Activities. Copies of Ordinance No. C-11-42 and Resolution No. 07-101 may be obtained from the City Clerk's Office on the 7th Floor of City Hall, 100 N. Andrews Avenue, Fort Lauderdale, Florida. The Ordinance may also be viewed on the City's website at <https://www.fortlauderdale.gov/home/showdocument?id=6036>.

1.13 Debarred or Suspended Bidders or Proposers

The proposer certifies, by submission of a response to this solicitation, that neither it nor its principals and sub-consultants are presently debarred or suspended by any Federal department or agency.

1.14 Prohibition Against Contracting with Scrutinized Companies

Subject to *Odebrecht Construction, Inc., v. Prasad*, 876 F.Supp.2d 1305 (S.D. Fla. 2012), *affirmed*, *Odebrecht Construction, Inc., v. Secretary, Florida Department of Transportation*, 715 F.3d 1268 (11th Cir. 2013), with regard to the "Cuba Amendment," the Contractor certifies that it is not on the Scrutinized Companies with Activities in Sudan List or the Scrutinized Companies with Activities in the Iran Petroleum Energy Sector List, and that it does not have business operations in Cuba or Syria, as provided in Section 287.135, Florida Statutes (2023), as may be amended or revised. As to any contract for goods or services of any amount and as to the renewal of any contract for goods or services of any amount, the Contractor certifies that it is not on the Scrutinized Companies that Boycott Israel List created pursuant to Section 215.4725, Florida Statutes (2023), as may be amended or revised, and that it is not engaged in a boycott of Israel. The City may terminate this Agreement at the City's option if the Contractor is found to have submitted a false certification as provided under subsection (5) of Section 287.135, Florida Statutes (2023), as may be amended or revised, or been placed on the Scrutinized Companies with Activities in Sudan List or the Scrutinized Companies with Activities in the Iran Petroleum Energy Sector List or the Scrutinized Companies that Boycott Israel List created pursuant to Section 215.4725, Florida Statutes (2023), as may be amended or revised, or is engaged in a boycott of Israel or has been engaged in business operations in Cuba or Syria, as defined in Section 287.135, Florida Statutes (2023), as may be amended or revised.

By submitting a proposal or response, the company, principals, or owners certify that it is not listed on the Scrutinized Companies with Activities in Sudan List or listed on the Scrutinized Companies with Activities in the Iran Petroleum Energy Sector List or is engaged in business operations in Cuba or Syria.

1.15 Inconsistencies

Any seeming inconsistency between different provisions of the plans, specifications, proposal or contract, or any point requiring explanation must be inquired into by the proposer, in writing up to the Q&A End Date, as published in the solicitation document. After proposals are opened, the proposers shall abide by the decision of the City as to such interpretation. No modifications to proposals will be permitted after the date and hour of the proposal opening.

1.16 Addenda and Interpretations

No interpretations of the meaning of the plans, specifications or other contract documents will be made orally to any proposer. Prospective proposers must request such interpretation in writing as instructed in the RFP. To be considered, such request must be received by the Q&A deadline as indicated in the City's online strategic sourcing platform. Material changes, if any, to the scope of services or bidding procedures will only be transmitted by written addendum. It is the proposer's responsibility to verify if addenda have been issued in the City's online strategic sourcing platform. Failure of any proposer to receive any such addenda or interpretation shall not relieve any proposer from any obligation under its RFP as submitted. All addenda so issued shall become a part of the contract document. Proposer shall verify in the City's online strategic sourcing platform that he/she has all addenda before submitting a proposal.

1.17 Forms of Proposals

Each proposal and its accompanying statements must be submitted electronically, in good order with all forms and blanks completed. The proposal must be signed by one duly authorized to do so, and in case signed by a deputy or subordinate, the principal's properly written authority to such deputy or subordinate must accompany the proposal. No proposal will be accepted, for any reason whatsoever, which is not submitted to the City as stated above, within the specified time.

1.18 Bids Firm for Acceptance (120 days)

Proposer warrants, by virtue of bidding, that his proposal and the prices quoted in this proposal will be firm for acceptance by the City for a period of one hundred and twenty (120) days from the date of bid opening unless otherwise stated in the RFP. The City shall award contract within this time period or shall request to the recommended awarded vendor an extension to hold pricing, until products/services have been awarded.

1.19 Additional Items or Services

The City may require additional items or services of a similar nature, but not specifically listed in the contract. The DBF agrees to provide such items or services, and shall provide the City prices on such additional items or services. If the price(s) offered are not acceptable to the City, and the situation cannot be resolved to the satisfaction of the City, the City reserves the right to procure those items or services from other vendors, or to cancel the contract upon giving the DBF thirty (30) days' written notice.

1.20 Deletion or Modification of Services

The City reserves the right to delete any portion of the Contract at any time without cause, and if such right is exercised by the City, the total fee shall be reduced in the same ratio as the estimated cost of the work deleted, bears to the estimated cost of the work originally planned. If work has already been accomplished on the portion of the Contract to be deleted, the DBF shall be paid for the deleted portion on the basis of the estimated percentage of completion of such portion.

If the DBF and the City agree on modifications or revisions to the task elements, after the City has approved work to begin on a particular task or project, the DBF will submit a request for a Change Order and a revised budget to the City for approval prior to proceeding with the work.

1.21 Rejection of Proposals

The City reserves the right to reject any proposal if the evidence submitted by the proposer, or if the investigation of such proposer, fails to satisfy the City that such proposer is properly qualified to carry out the obligations and to complete the work contemplated. Any or all proposals will be rejected, if there is reason to believe that collusion exists among proposers. A proposal will be considered irregular and may be rejected, if it shows serious omissions, alterations in form, additions not called for, conditions or unauthorized alternates, or irregularities of any kind. The City reserves the right to reject any or all proposals and to waive such technical errors as may be deemed best for the interests of the City.

1.22 Bid Protest Procedure

Any proposer or bidder who is not recommended for award of a contract and who alleges a failure by the City to follow the City's procurement ordinance or any applicable law may protest to the Procurement Division – Deputy Director of Finance, by delivering a letter of protest within five (5) days after a Notice of Intent to award is posted on the City's website at the following link:
<https://www.fortlauderdale.gov/government/departments-a-h/finance/procurement-services/notices-of-intent-to-award>

The complete protest ordinance may be found on the City's website at the following link:

https://library.municode.com/fl/fort_lauderdale/codes/code_of_ordinances?nodeId=COOR_CH2AD_ARTVFI_DIV2PR_S2-182DIREPRAWINAW

1.23 Local Business Preference

Not applicable to this solicitation.

1.24 Disadvantaged Business Enterprise Preference

Not applicable to this solicitation.

1.25 Resolution of Disputes

Questions, claims, difficulties and disputes of whatever nature which may arise relative to the technical interpretation of the Contract Documents and fulfillment of this Agreement as to the character, quality, amount and value of any work done and

materials furnished, or proposed to be done or furnished under, or by reason of, the Contract Documents which cannot be resolved by mutual agreement of City Project Manager and Consultant shall be submitted to the City Manager or his designee and Consultant's representative for resolution. Prior to any litigation being commenced, for any disputes which remain unresolved, within sixty (60) days after final completion of the Work, the Parties shall participate in mediation to address all unresolved disputes to a mediator agreed upon by the Parties. Should any objection not be resolved in mediation, the Parties retain all their legal rights and remedies provided under the laws of Florida. Failure by a Party to comply in strict accordance with the requirements of this Article, then said Party specifically waives all of its rights provided hereunder, including its rights and remedies under the laws of Florida.

1.25.1 All non-technical administrative disputes (such as billing and payment) shall be determined by Contract Administrator.

1.25.2 During the pendency of any dispute and after a determination thereof, Consultant and Contract Administrator shall act in good faith to mitigate any potential damages including utilization of construction schedule changes and alternate means of construction. During the pendency of any dispute arising under this Agreement, other than termination herein, Consultant shall carry on the Work and adhere to the progress schedule. The Work shall not be delayed or postponed pending resolution of any disputes or disagreements.

1.25.3 For any disputes which remain unsolved, within sixty (60) calendar days after Final Completion of the Work, the Parties shall participate in mediation to address all unresolved disputes. A mediator shall be mutually agreed upon by the Parties. Should any objection not be resolved in mediation, the Parties retain all their legal rights and remedies under applicable law. If a Party objecting to a determination, fails to comply in strict accordance with the requirements of this Article, said Party specifically waives all of its rights provided hereunder, including its rights and remedies under applicable law.

1.26 Withdrawals

Any proposer may, without prejudice to him/herself, withdraw his/her proposal at any time prior to the expiration of the time during which proposals may be submitted. Such request for withdrawal must be in writing and signed in the same manner and by the same person who signed the proposal. After expiration of the period for receiving proposals, no proposal can be withdrawn, modified, or explained.

****END OF SECTION 1****

SECTION 2 GENERAL CONDITIONS

Unless otherwise modified in the Project's Special Conditions, the following General Conditions shall be part of the Contract:

GC - 01 - DEFINITIONS - The following words and expressions, or pronouns used in their stead, shall wherever they appear in the Contract and the Contract Documents, be construed as follows:

"Addendum" or "Addenda" - shall mean the additional Contract provisions issued in writing, by the Engineer, prior to the receipt of bids.

"Bid" – shall mean the offer or proposal of the Bidder submitted on the prescribed form setting forth the prices for the Work to be performed.

"Bidder" – shall mean any person, firm, company, corporation or entity submitting a bid for the Work.

"Bonds" –shall mean bid, performance and payment bonds and other instruments of security, furnished by Contractor and his surety in accordance with the Contract Documents.

"City" – shall mean the City of Fort Lauderdale, Florida, a Florida municipal corporation. In the event the City exercises its regulatory authority as a government body, the exercise of such regulatory authority and the enforcement of any rules, regulations, codes, laws and ordinances shall be deemed to have occurred pursuant to City's authority as a governmental body and shall not be attributable in any manner to the City as a party to this Contract.

"Consultant" – shall mean a person, firm, company, corporation or other entity employed by the City to perform the professional services for the project.

"Contractor" – shall mean the successful Bidder who has been employed by the City to perform the construction and related services for the project.

"Contract Work" - shall mean everything expressed or implied to be required to be furnished and furnished by the Contractor by any one or more of the parts of the Contract Documents referred to in the Contract hereof. In the case of any inconsistency in or between any parts of this Contract, the Project Manager shall determine which shall prevail.

"Design Documents" – shall mean the construction plans and specifications included as part of a Bid/Proposal Solicitation prepared either by the City or by the Consultant under a separate Agreement with the City.

"Engineer" - shall include the terms "professional engineer" and "licensed engineer" and means a person who is licensed to engage in the practice of engineering under

Florida Statute, Chapter 471. An Engineer may be a City employee or a consultant hired by the City.

"Engineer of Record" – a person who is licensed to engage in the practice of engineering under Florida Statute, Chapter 471 and is a employee or member of the Design Build Firm.

"Extra Work" - shall mean work other than that required by the Contract.

"Inspector" – shall mean an authorized representative of the City assigned to make necessary inspections of materials furnished by Contractor and of the Work performed by Contractor.

"Notice" - shall mean written notice sent by certified United States mail, return receipt requested, or sent by commercial express carrier with acknowledgement of delivery, or via fax or email, or by hand delivery with a request for a written receipt of acknowledgment of delivery and shall be served upon the Contractor either personally or to its place of business listed in the Bid.

"Owner" - shall mean the City of Fort Lauderdale.

"Project Manager" - shall mean a professional designated by the City to manage the Project under the supervision and direction of the Public Works Director or designee.

"Public Works Director" – shall mean the Public Works Director of the City of Fort Lauderdale.

"Site" - shall mean the area upon or in which the Contractor's operations are carried out and such other areas adjacent thereto as may be designated as such by the Project Manager.

"Sub-contractor" - shall mean any person, firm, company, corporation or other entity, other than employees of the Contractor, who or which contracts with the contractor, to furnish, or actually furnishes labor and materials, or labor and equipment, or labor, materials and equipment at the site.

"Surety" - shall mean any corporation or entity that executes, as Surety, the Contractor's performance and payment bond securing the performance of this Contract.

GC – 02 - SITE INVESTIGATION AND REPRESENTATION - The Contractor acknowledges that it has satisfied itself as to the nature and location of the Work under the Contract Documents, the general and local conditions of the Site, particularly those bearing upon availability of transportation, disposal, handling and storage of materials, availability of labor, water, electric power, and roads, field conditions, the type of equipment and facilities needed preliminary to and during the prosecution of the Work and all other matters which can in any way affect the Work or the cost thereof under the Contract Documents.

The Contractor acknowledges that it has conducted extensive tests, examinations and investigations and represents and warrants a thorough familiarization with the nature and extent of the Contract Documents, the Work, locality, soil conditions, moisture conditions and all year-round local weather and climate conditions (past and present), and, in reliance on such tests, examination and investigations conducted by Contractor and the Contractor's experts, has determined that no conditions exist that would in any manner affect the Bid Price and that the project can be completed for the Bid Price submitted.

Any failure by the Contractor to acquaint itself with all the Site conditions shall not relieve Contractor from responsibility for properly estimating the difficulty or cost thereof under the Contract Documents.

GC - 03 - SUBSTITUTIONS - If the Contractor desires to use materials and/or products of manufacturer's names different from those specified in the Contract Documents, the Bidder requesting the substitution shall make written application as described herein. The burden of proving the equality of the proposed substitution rests on the Contractor making the request. To be acceptable, the proposed substitution shall meet or exceed all expressed requirements of the

Contract Documents and shall be submitted upon the Contractor's letterhead. The following requirements shall be met in order for the substitution to be considered:

1. Requests for substitution shall be accompanied by such technical data, as the party making the request desires to submit. The Project Manager will consider reports from reputable independent testing laboratories, verified experience records from previous users and other written information valid in the circumstances; and
2. Requests for substitution shall completely and clearly indicate in what respects the materials and/or products differ from those indicated in the Contract Documents; and
3. Requests for substitution shall be accompanied by the manufacturer's printed recommendations clearly describing the installation, use and care, as applicable, of the proposed substitutions; and
4. Requests for substitution shall be accompanied by a complete schedule of changes in the Contract Documents, if any, which must be made to permit the use of the proposed substitution.

If a proposed substitution is approved by the Project Manager, an addendum will be issued to prospective bidders not less than three (3) working days prior to the date set for opening of bids. Unless substitutions are received and approved as described above, the successful Bidder shall be responsible for furnishing materials and products in strict accordance with the Contract Documents.

GC- 04 – CONSTRUCTION RESOURCES – Contractor shall provide all labor and equipment necessary to complete the installation within a timely manner. Contractor shall provide details as to manpower and equipment to be dedicated to the project in its Work Plan. Contractor is responsible for making arrangements, obtaining and purchasing construction water services if required to complete the work.

GC - 05 - CONTROL OF THE WORK - The Project Manager shall have full control and direction of the Work in all respects. The Project Manager and/or his authorized designee(s) shall, at all times, have the right to inspect the Work and materials. The Contractor shall furnish all reasonable facilities for obtaining such information, as the Project Manager may desire respecting the quality of the Work and materials and the manner of conducting the Work. Should the Contractor be permitted to perform night Work, or to vary the period which work is ordinarily carried on in the daytime, he shall give ample notice to the Project Manager so that proper and adequate inspection may be provided. Such Work shall be done only under such regulations as are furnished in writing by the Project Manager, and no extra compensation shall be allowed to the Contractor therefore. In the event of night work, the Contractor shall furnish such light, satisfactory to the Project Manager, as will ensure proper inspection. Nothing herein contained shall relieve the Contractor from compliance with any and all City ordinances relating to noise or Work during prohibited hours.

GC - 06 - SUB-CONTRACTOR - The Contractor shall not sublet, in whole or any part of the Work without the written consent and approval of the Project Manager. Within ten (10) days after official notification of starting date, the Contractor must submit in writing, to the Project Manager, a list of all Sub-contractors. No Work shall be done by any sub-contractor until such Sub-contractor has been officially approved by the Project Manager. A sub-contractor not appearing on the original list will not be approved without written request submitted to the Project Manager and approved by the Public Works Director. In all cases, the Contractor shall give his personal attention to the Work of the Sub-contractors and the Sub-contractor is liable to be discharged by the Contractor, at the direction of the Project Manager, for neglect of duty, incompetence or misconduct.

Acceptance of any sub-contractor, other person, or organization by the Project Manager shall not constitute a waiver of any right of Project Manager to reject defective Work or Work not in conformance with the Contract Documents.

Contractor shall be fully responsible for all acts and omissions of its Sub-contractors and of persons and organizations directly or indirectly employed by them and of persons and organizations for whose acts any of them may be liable to the same extent that he is responsible for the acts and omissions of persons directly employed by him. Nothing in the Contract Documents shall create any contractual relationship between City and any sub-contractor or other person or organization having a direct contract with Contractor, nor shall it create any obligation on the part of City to pay or to see to the payment of any moneys due to any sub-contractor or other person, or organization, except as may otherwise be required by law.

GC - 07 - QUANTITIES - Contractor recognizes and agrees that the quantities shown on plans and Bid/Price Schedule are estimates only and may vary during actual

construction. No change shall be made involving any departure from the general scheme of the Work and that no such change involving a material change in cost, either to the City or Contractor, shall be made, except upon written permission of the City. However, the Project Manager shall have the right to make minor alternations in the line, grade, plan, form or materials of the Work herein contemplated any time before the completion of the same. That if such alterations shall diminish the quantity of the Work to be done, such alterations shall not constitute a claim for damages or anticipated profits. That if such alterations increase the amount of the Work to be done, such increase shall be paid for according to the quantity actually performed and at the unit price or prices stipulated therefore in the Contract. The City shall, in all cases of dispute, determine the amount or quantity of the several kinds of Work which are to be paid for under this Contract, and shall decide all questions relative to the execution of the same, and such estimates and decisions shall be final and binding.

Any Work not herein specified, which might be fairly implied as included in the Contract, of which the City shall judge, shall be done by the Contractor without extra charge. However, such cost increases shall be authorized either by the Public Works Director or designee, or the City Commission based upon the purchasing threshold amounts provided for in Chapter 2 of the City of Fort Lauderdale's Code of Ordinances.

GC - 08 - NO ORAL CHANGES - Except to the extent expressly set forth in the Contract, no change in, or modification, termination or discharge of the Contract in any form whatsoever, shall be valid or enforceable unless it is in writing and signed by the parties charged, therewith or their duly authorized representative.

GC - 09 - PERMITS AND PROTECTION OF PUBLIC – Permits on file with the City and/or those permits to be obtained by the Contractor, shall be considered directive in nature, and will be considered a part of this Contract. A copy of all permits shall be given to the City and become part of the Contract Documents. Terms of permits shall be met prior to acceptance of the Work and release of the final payment.

Contractor shall secure all permits and licenses required for completing the Project. Contractor will obtain the necessary State, County, and City construction/work permits if required. The Contractor shall comply with all applicable Codes, Standards, Specifications, etc. related to all aspects of the Project.

Where there are telephones, light or power poles, water mains, conduits, pipes or drains or other construction, either public or private, in or on the streets or alleys, the Work shall be so conducted that no interruption or delay will be caused in the operation or use of the same. Proper written notice shall be given to all affected parties prior to proceeding with the Work.

The Contractor shall not be permitted to interfere with public travel and convenience by grading or tearing up streets indiscriminately, but the Work of constructing the various items in this contract shall proceed in an orderly, systematic and progressive manner.

GC - 10 - DISEASE REGULATIONS - The Contractor shall enforce all sanitary regulations and take all precautions against infectious diseases as the Project Manager may deem necessary. Should any infectious or contagious diseases occur among his employees, he shall arrange for the immediate removal of the employee from the Site and isolation of all persons connected with the Work.

GC - 11 - CONTRACTOR TO CHECK PLANS, SPECIFICATIONS, AND DATA - The Contractor shall verify all dimensions, quantities, and details shown on the plans, supplementary drawings, schedules, and shall notify the Project Manager of all errors, omissions, conflicts and discrepancies found therein within three (3) working days of discovery. Failure to discover or correct errors, conflicts, or discrepancies shall not relieve the Contractor of full responsibility for unsatisfactory Work, faulty construction, or improper operation resulting therefrom nor from rectifying such condition at its own expense.

GC - 12 - MATERIALS AND WORKMANSHIP - All material shall be new and the workmanship shall, in every respect, be in conformity with approved modern practice and with prevailing standards of performance and quality. In the event of a dispute, the Project Manager's decision shall be final. Wherever the Plans, Specifications, Contract Documents, or the directions of the Project Manager are unclear as to what is permissible and/or fail to note the quality of any Work, that interpretation will be made by the Project Manager, which is in accordance with approved modern practice, to meet the particular requirements of the Contract.

GC - 13 - SAFEGUARDING MARKS - The Contractor shall safeguard all points, stakes, grade marks, monuments, and benchmarks made or established on the Work, bear the cost of re-establishing same if disturbed, or bear the entire expense of rectifying Work improperly installed due to not maintaining or protecting or for removing without authorization, such established points, stakes and marks. The Contractor shall safeguard all existing and known property corners, monuments and marks not related to the Work and, if required, shall bear the cost of having them re-established by a licensed Professional surveyor registered in the State of Florida if disturbed or destroyed during the course of construction.

GC - 14 - RESTROOM FACILITIES - Contractor shall provide portable toilet facilities for employee's use at a location within the Work site to be determined by the City.

GC - 15 - PROGRESS MEETINGS - Weekly Status meetings will be conducted with representatives from the City and the Contractor. Contractor shall budget time to participate in such meetings. A well-run Project should result in short meetings.

GC - 16 - ISSUE RESOLUTION - Should Contractor become engaged in a dispute with a resident or a City employee, the Contractor shall report the situation to the Project Manager immediately. It shall be mandatory that the City participate in any dispute resolution. Failure of Contractor personnel to notify the City shall obligate Contractor to replace the offending employee immediately if requested by the City.

GC - 17 - CITY SECURITY-CONTRACTOR AND SUBCONTRACTOR EMPLOYEE INFORMATION - Prior to commencing work, Contractor shall provide to the City a list of all personnel and sub-contractors on site. The list will include the name, address, birth date and driver's license number for all personnel. All personnel and subcontractors on site will have on their person a company photo ID during all stages of the construction. Contractor shall provide standard required personal information per current City procedures.

GC - 18 - POST-CONSTRUCTION SURVEY - The Contractor shall provide as-built survey, sealed and signed by a registered surveyor in the State of Florida, as a condition of final payment.

GC - 19 - KEY PERSONNEL - Contractor shall provide as part of the Work Plan, resumes for all key project personnel providing supervision and project management functions. Resumes shall include work history and years of experience performing this type of work.

GC - 20 - EXISTING UTILITY SERVICE - All existing utility service shall be maintained with a minimum of interruption at the expense of the Contractor.

GC - 21 - JOB DESCRIPTION SIGNS – Contractor, at Contractor's expense, shall furnish, erect, and maintain suitable weatherproof signs on jobs over \$100,000 containing the following information:

1. City Seal (in colors)
2. Project or Improvement Number
3. Job Description
4. Estimated Cost
5. Completion Date

Minimum size of sign shall be four feet high, eight feet wide and shall be suitably anchored. The entire sign shall be painted and present a pleasing appearance. Exact location of signs will be determined in the field. Two (2) signs will be required, one at each end of the job. All costs of this work shall be included in other parts of the work.

GC - 22 - FLORIDA EAST COAST RIGHT-OF-WAY - Whenever a City contractor is constructing within the Florida East Coast Railway Company's Right-of-Way, it will be mandatory that the contractor carry bodily injury and property damage insurance in amounts satisfactory to the Florida East Coast Company. This insurance requirement shall be verified by the contractor with the Florida East Coast Company prior to commencing work and maintained during the life of the Contract.

GC - 23 - ACCIDENTS - The Contractor shall provide such equipment and facilities as are necessary and/or required, in the case of accidents, for first aide services to be provided to a person who may be injured during the project duration. The Contractor shall also comply with the OSHA requirements as defined in the United States Labor Code 29 CFR 1926.50.

In addition, the Contractor must report immediately to the Project Manager every accident to persons or damage to property, and shall furnish in writing full information, including testimony of witnesses regarding any and all accidents.

GC - 24 - SAFETY PRECAUTIONS - Contractor must adhere to the applicable environmental protection guidelines for the duration of a project. If hazardous waste materials are used, detected or generated at any time, the Project Manager must be immediately notified of each and every occurrence. The Contractor shall comply with all codes, ordinances, rules, orders and other legal requirements of public authorities (including OSHA, EPA, DERM, the City, Broward County, State of Florida, and Florida Building Code), which bear on the performance of the Work.

The Contractor shall take the responsibility to ensure that all Work is performed using adequate safeguards, including but not limited to: proper safe rigging, safety nets, fencing, scaffolding, barricades, chain link fencing, railings, barricades, steel plates, safety lights, and ladders that are necessary for the protection of its employees, as well as the public and City employees. All riggings and scaffolding shall be constructed with good sound materials, of adequate dimensions for their intended use, and substantially braced, tied or secured to ensure absolute safety for those required to use it, as well as those in the vicinity. All riggings, scaffolding, platforms, equipment guards, trenching, shoring, ladders and similar actions or equipment shall be OSHA approved, as applicable, and in accordance with all Federal, State and local regulations.

GC - 25 - DUST PREVENTION - The Contractor shall, by means of a water spray, or temporary asphalt pavement, take all necessary precautions to prevent or abate a dust nuisance arising from dry weather or Work in an incomplete stage. All costs of this Work shall be included in the cost of other parts of the Work.

Should the Contractor fail to abate a dust nuisance the Manager may stop the Work until the issue is resolved to the City's satisfaction.

GC - 26 - SITE CLEANUP AND RESTORATION – The Contractor shall remove all debris and unused or discarded materials from the work site daily. Contractor shall clean the work site to remove all directional drilling "Driller's Mud" materials. No "Driller's Mud" residue shall be allowed to remain in the soil or on the surface of the land or vegetation. All debris and drilling materials must be disposed of offsite at an approved location. The Contractor shall promptly restore all areas disturbed that are outside the Project limits in equal or better condition at no additional cost to the City.

GC - 27 - COURTEOUS BEHAVIOR AND RESPECT FOR RESIDENTS AND PROPERTY – The Contractor and its employees, associates and sub-contractors shall maintain courteous behavior at all times and not engage in yelling, loud music, or other such activities. Contractor's employees shall not leave trash or other discarded items at the Work Site, especially on any private property. In the event complaints arise, Contractor shall immediately remove such offending employees from the project if requested to do so by the Project Manager. Contractor's employees

shall not trespass on any private property unless necessary to complete the work but with prior permission from the owner.

Contractor shall notify and obtain permission from the residents 24 hours in advance when planning to work within the resident's property. In addition, Contractor shall notify the resident prior to entering their property to perform work or inspect/investigate the work site. Contractor shall not block residents' driveways unnecessarily. Contractor shall not park equipment on landscaped areas when the vehicle is not needed for the current construction activities. Contractor shall be responsible for repair and/or replacement of all damaged landscaping within 48 hours including repairing vehicle wheel impressions, irrigation systems, lighting systems, structures, or any other items of resident's property. Contractor shall not destroy, damage, remove, or otherwise negatively impact any landscaping within or outside the right-of-way without prior approval from the Project Manager.

GC - 28 - PLACING BARRICADES AND WARNING LIGHTS - The Contractor shall furnish and place, at Contractor's own expense, all barricades, warning lights, automatic blinker lights and such devices necessary to properly protect the work and vehicular and pedestrian traffic. Should the Contractor fail to erect or maintain such barricades, warning lights, etc., the Project Manager may, after 24 hours' notice to the Contractor, proceed to have such barricades and warning lights placed and maintained by City or other forces and all costs incurred thereof charged to the Contractor and may be retained by the City from any monies due, or to become due, to the Contractor.

GC - 29 - TRAFFIC CONTROL - The Contractor shall coordinate all Work and obtain, through the City's Transportation and Mobility Department, Broward County, Florida Department of Transportation, as applicable, any permits required to detour traffic or close any street before starting to work in the road

All traffic control devices, flashing lights, signs and barricades shall be maintained in working condition at all times and conform to Manual of Uniform Traffic Control Devices (MUTCD), latest edition.

GC - 30 - COORDINATION - The Contractor shall notify all utilities, transportation department, etc., in writing, with a copy to the Project Manager before construction is started and shall coordinate its Work with them. The Contractor shall cooperate with the owners of any underground or overhead utility lines in their removal, construction and rearrangement operations in order that services rendered by these parties will not be unnecessarily interrupted.

The Contractor shall arrange its Work and dispose of its materials so as to not interfere with the operation of other contractors engaged upon adjacent work, and to join its Work to that of others in a proper manner, and to perform its Work in the proper sequence in relation to that of other contractors as may be directed by the Project Manager.

Each Contractor shall be responsible for any damage done by it or its agents to the work performed by another contractor.

GC - 31 - WATER - Bulk water used for construction, flushing pipelines, and testing shall be obtained from fire hydrants. Contractor shall make payment for hydrant meter at Treasury Billing Office, 1st Floor, City Hall, 100 N. Andrews Avenue. With the paid receipt, contractor can pick up hydrant meter at the utility location office. No connection shall be made to a fire hydrant without a meter connected.

GC - 32 - PROHIBITION AGAINST CONTRACTING WITH SCRUTINIZED COMPANIES - Subject to *Odebrecht Construction, Inc., v. Prasad*, 876 F.Supp.2d 1305 (S.D. Fla. 2012), *affirmed*, *Odebrecht Construction, Inc., v. Secretary, Florida Department of Transportation*, 715 F.3d 1268 (11th Cir. 2013), with regard to the "Cuba Amendment," the Contractor certifies that it is not on the Scrutinized Companies with Activities in Sudan List or the Scrutinized Companies with Activities in the Iran Petroleum Energy Sector List, and that it does not have business operations in Cuba or Syria, as provided in Section 287.135, Florida Statutes (2022), as may be amended or revised. As to any contract for goods or services of any amount and as to the renewal of any contract for goods or services of any amount, the Contractor certifies that it is not on the Scrutinized Companies that Boycott Israel List created pursuant to Section 215.4725, Florida Statutes (2022), as may be amended or revised, and that it is not engaged in a boycott of Israel. The City may terminate this Agreement at the City's option if the Contractor is found to have submitted a false certification as provided under subsection (5) of Section 287.135, Florida Statutes (2022), as may be amended or revised, or been placed on the Scrutinized Companies with Activities in Sudan List or the Scrutinized Companies with Activities in the Iran Petroleum Energy Sector List or the Scrutinized Companies that Boycott Israel List created pursuant to Section 215.4725, Florida Statutes (2022), as may be amended or revised, or is engaged in a boycott of Israel, or has been engaged in business operations in Cuba or Syria, as defined in Section 287.135, Florida Statutes (2022), as may be amended or revised.

GC - 33 - USE OF FLORIDA LUMBER TIMBER AND OTHER FOREST PRODUCTS - In accordance with Florida Statute 255.20 (3), the City specifies that lumber, timber, and other forest products used for this Project shall be produced and manufactured in the State of Florida if such products are available and their price, fitness, and quality are equal. This requirement does not apply to plywood specified for monolithic concrete forms, if the structural or service requirements for timber for a particular job cannot be supplied by native species, or if the construction is financed in whole or in part from federal funds with the requirement that there be no restrictions as to species or place of manufacture.

The Bidder affirms by submitting a bid response to this solicitation that they will comply with section 255.20 (3) Florida Statutes.

GC - 34 - PUBLIC RECORDS/TRADE SECRETS/COPYRIGHT: The Proposer's response to the Solicitation is a public record pursuant to Florida law, which is subject to disclosure by the City under the State of Florida Public Records Law, Florida

Statutes Chapter 119.07 (“public Records Law”). The City shall permit public access to all documents, papers, letters or other material submitted in connection with this Solicitation and the Contract to be executed for this Solicitation, subject to the provisions of Chapter 119.07 of the Florida Statutes.

Any language contained in the Proposer’s response to the Solicitation purporting to require confidentiality of any portion of the Proposer’s response to the Solicitation, except to the extent that certain information is in the City’s opinion a Trade Secret pursuant to Florida law, shall be void. If a Proposer submits any documents or other information to the City which the

Proposer claims is Trade Secret information and exempt from Florida Statutes Chapter 119.07 (“Public Records Laws”), the Proposer shall clearly designate that it is a Trade Secret and that it is asserting that the document or information is exempt. The Proposer must specifically identify the exemption being claimed under Florida Statutes 119.07. The City shall be the final arbiter of whether any information contained in the Proposer’s response to the Solicitation constitutes a Trade Secret. The City’s determination of whether an exemption applies shall be final, and the proposer agrees to defend, indemnify, and hold harmless the City and the City’s officers, employees, and agent, against any loss or damages incurred by any person or entity as a result of the City’s treatment of records as public records. In addition, the proposer agrees to defend, indemnify and hold harmless the City and the City’s officers, employees, and agents, against any loss or damages incurred by any person or entity as a result of the City’s treatment of records as exempt from disclosure or confidential. Proposals purporting to be subject to copyright protection in full or in part will be rejected. The proposer authorizes the City to publish, copy and reproduce any and all documents submitted to the City bearing copyright symbols or otherwise purporting to be subject to copyright protection.

IF THE CONTRACTOR HAS QUESTIONS REGARDING THE APPLICATION OF CHAPTER 119, FLORIDA STATUTES, TO THE CONTRACTOR’S DUTY TO PROVIDE PUBLIC RECORDS RELATING TO THIS AGREEMENT, CONTACT THE CUSTODIAN OF PUBLIC RECORDS AT:

Telephone Number: (954) 828-5002

**Mailing Address: City Clerk’s Office
100 N. Andrews Avenue
Fort Lauderdale, Florida 33301-1016**

E-mail: prcontract@fortlauderdale.gov

Contractor shall:

1. Keep and maintain public records required by the City in order to perform the service.

2. Upon request from the City's custodian of public records, provide the City with a copy of the requested records or allow the records to be inspected or copied within a reasonable time at a cost that does not exceed the cost provided in Chapter 119, Florida Statutes (2023), as may be amended or revised, or as otherwise provided by law.
3. Ensure that public records that are exempt or confidential and exempt from public records disclosure requirements are not disclosed except as authorized by law for the duration of the contract term and following completion of this Agreement if the Contractor does not transfer the records to the City.
4. Upon completion of the Agreement, transfer, at no cost, to the City, all public records in possession of the Contractor or keep and maintain public records required by the City to perform the service. If the Contractor transfers all public records to the City upon completion of this Agreement, the Contractor shall destroy any duplicate public records that are exempt or confidential and exempt from public records disclosure requirements. If the Contractor keeps and maintains public records upon completion of this Agreement, the Contractor shall meet all applicable requirements for retaining public records. All records stored electronically must be provided to the City, upon request from the City's custodian of public records, in a format that is compatible with the information technology systems of the City.

****END OF SECTION 2****

SECTION 3 SPECIAL CONDITIONS

3.1 Definitions

Award – means the acceptance of a bid, offer or proposal by the proper authorized designee. The City Commission must approve all awards over the authority of the City Manager, with the exception of emergency purchases.

City – the City of Fort Lauderdale or the City Commission, a municipal corporation of the State of Florida.

City Commission – City Commission shall mean the governing and legislative body of the City.

Contract – This Agreement and all addenda, exhibits and amendments thereto between the City and the Design-Build Firm for this Project. Contract shall also mean the same as Agreement.

Design Build – Means a single contract with a Design-Build Firm for the design and construction of a City construction project.

Design Build Firm (DBF) – means a partnership, corporation, or other legal entity that is certified under Florida Statute 489.119 to engage in contracting through a certified or registered general contractor or a certified or registered building contractor as the qualifying agent or is certified under Florida Statute 471.023 to practice or to offer to practice engineering; certified under Florida Statute 481.219 to practice or to offer to practice architecture, or certified under Florida Statute 481.319 to practice or to offer to practice landscape architecture.

Design Criteria Package (DCP) – DCP shall mean those certain conceptual plans and specifications and performance-oriented drawings or specifications of the Project, as prepared and sealed by the Design Criteria Professional, and in compliance with the requirements of Section 287.055, Florida Statutes.

Design Criteria Professional – means a firm which holds a current certificate or registration under Chapter 481, Florida Statutes, to practice architecture or landscape architecture or a firm which holds a current certificate as a registered engineer under Chapter 471, Florida Statutes, to practice engineering and who is employed by or under contract by the City to provide professional architect services, landscape architect services, or engineering services in connection with the preparation of the Design Criteria Package.

Guaranteed Maximum Price (GMP) – the mutually agreed upon contract price to be paid to the DBF for the work, with the DBF agreeing to complete the work without additional payment. The guaranteed maximum price is not subject to increase, except as expressly allowed by the City. Savings below the maximum guaranteed price are

shared between owner and DBF, whereas the DBF assumes the responsibility for any overrun beyond the Guaranteed maximum price.

Negotiate – any form of that word means to conduct legitimate, arm’s length discussion and conferences to reach an agreement on a term or price.

Notice to Proceed –. A written notice to Contractor authorizing the commencement of the activities identified in the notice or as described in the Contract Documents.

Professional Services – means those services within the scope of the practice of architecture, professional engineering, landscape architect, or registered surveying and mapping, as defined by the laws of the state, or those performed by any architect, professional engineer, landscape architect, or registered surveyor and mapper in connection with his or her professional employment or practice.

Project Manager – an authorized representative of the City assigned to the Project by the City, assigned to make necessary observations of materials furnished by DBF and of the Work performed by DBF as detailed.

Proposal – means the proposal or submission submitted by a Proposer. The terms “Proposal” and “Bid” are used interchangeably and have the same meaning.

Proposer – means one who submits a Proposal in response to a solicitation. The terms “Proposer” and “Bidder” are used interchangeably and have the same meaning.

Substantial Completion – the date(s) certified by the Project Manager that all conditions of the permits and regulatory agencies have been met for the City’s intended use of the Project, and all construction has been performed in accordance with the Contract Documents so City can fully utilize, as opposed to partially utilize, the Project for its intended purpose.

Work – the completed construction required by the Contract Documents, as permitted, including all labor necessary to produce such construction, and all materials and equipment incorporated or to be incorporated in such construction.

3.2 Responsiveness

In order to be considered responsive to the solicitation, the firm’s response shall fully conform in all material respects to the solicitation and all of its requirements, including all form and substance.

3.3 Responsibility

In order to be considered responsible, DBF shall be fully capable of meeting all of the requirements of the solicitation and the subsequent contract; must possess the full capability, including financial and technical capacity, to perform as contractually required; and must fully document the ability to provide good faith performance.

3.4 Sub-Consultants

A Sub-Consultant is an individual or firm contracted by the DBF to assist in the performance of services required under this RFP. A Sub-Consultant shall be paid through DBF and not paid directly by the City. Sub-Consultants are permitted by the City in the performance of the services pursuant to the Agreement. DBF must clearly reflect in its proposal, the major Sub-Consultant(s) to be utilized in the performance of required services. The City retains the right to accept or reject any Sub-Consultant proposed in the response of successful DBFs or prior to contract execution. Any and all liabilities regarding the use of a Sub-Consultant shall be borne solely by the successful DBF, and insurance for each Sub-Consultant must be maintained in good standing and approved by the City throughout the duration of the Contract. Neither successful DBF nor any of its Sub-Consultants is considered to be employees or agents of the City. Failure to list all Sub-Consultants and provide the required information may disqualify any proposed Sub-Consultant from performing work under this RFP.

DBFs shall include in their responses, the requested Sub-Consultant information and include all relevant information required of the DBF. In addition, within five (5) working days after the identification of the award to the successful DBF, the DBF shall provide a list confirming the Sub-Consultant(s) that the successful DBF intends to utilize in the Contract, if applicable. The list shall include, at a minimum, the name, and location of the place of business for each Sub-Consultant, the services Sub-Consultant will provide relative to any contract that may result from this RFP, Sub-Consultant's hourly rates or fees, any applicable licenses, insurance, references, ownership, and other information required of the DBF. No more than twenty percent (20%) of the team members selected for this Project can be substituted and any and all team and/or staff substitutions must be approved by the City in advance.

3.5 Contract Term

Time is of the essence for the DBF's performance of the Work.

The City will enter into a Not-To-Exceed (NTE) contract with the successful DBF for a Guaranteed Maximum Price (GMP) for the Work. The terms and conditions of this contract are fixed price and for a fixed period of time. The DBF submitted proposal is to be a NTE GMP proposal for completing the Scope of Work in the RFP. The DBF will provide a Schedule of Values to the City for its approval. The total of the Schedule of Values will be this NTE GMP contract price for the work.

The DBF shall not assign, transfer or sub-contract any work either in whole or in part, without prior written approval of the City. The submittal responses shall be valid until such time as City Commission awards a contract as a result of this RFP.

City reserves the right, where it may serve the City of Fort Lauderdale's best interest, to request additional information or clarification from proposers including, but not limited to, oral interviews as requested by the Evaluation Committee.

The City of Fort Lauderdale reserves the right to waive formalities in any proposal and further reserves the right to take any other action that may be necessary in the best interest of the City.

The City reserves the right to let other contracts in connection with this Project, provided it does not interfere with DBF's work or schedule. By submitting a proposal, each firm is confirming that the firm has not been placed on the convicted vendors list as described in [Florida Statute §287.133 \(2\) \(a\)](#).

3.6 Unauthorized Work

The successful DBF(s) shall not begin work until a Contract and a Notice to Proceed has been issued. DBF(s) agree and understand that a purchase order and/or task order shall be issued and provided to the DBF(s) following City Commission award.

3.7 Uncontrollable Circumstances ("Force Majeure")

The City and Contractor will be excused from the performance of their respective obligations under this agreement when and to the extent that their performance is delayed or prevented by any circumstances beyond their control including, fire, flood, explosion, strikes or other labor disputes, act of God or public emergency, war, riot, civil commotion, malicious damage, act or omission of any governmental authority, delay or failure or shortage of any type of transportation, equipment, or service from a public utility needed for their performance, provided that:

- 3.7.1** The non-performing party gives the other party prompt written notice describing the particulars of the Force Majeure including, but not limited to, the nature of the occurrence and its expected duration, and continues to furnish timely reports with respect thereto during the period of the Force Majeure;
- 3.7.2** The excuse of performance is of no greater scope and of no longer duration than is required by the Force Majeure;
- 3.7.3** No obligations of either party that arose before the Force Majeure causing the excuse of performance are excused as a result of the Force Majeure; and
- 3.7.4** The non-performing party uses its best efforts to remedy its inability to perform. Notwithstanding the above, performance shall not be excused under this Section for a period in excess of two (2) months, provided that in extenuating circumstances, the City may excuse performance for a longer term. Economic hardship of the Contractor will not constitute Force Majeure. The term of the agreement shall be extended by a period equal to that during which either party's performance is suspended under this Section.

3.8 News Releases/Publicity

News releases, publicity releases, or advertisements relating to this contract, or the tasks or projects associated with the project shall not be made without prior City approval.

3.9 Proposal Bond

Proposers can submit proposal bonds for projects **four** different ways:

- 1) The City's online strategic sourcing platform allows bidders to submit bid bonds electronically directly through their system using **Surety 2000**. For more information on this feature and to access it, contact **customer care department**.
- 2) If bid bonds are not submitted via Surety 2000, Bidders may upload their original executed proposal bond on the City's online strategic sourcing platform to accompany their electronic proposal, and deliver the original, signed and sealed hard copy within **five (5)** business days after bid opening, with the company name, bid number and title clearly indicated. Proposal bond shall be written by a surety insurer authorized to do business in the State of Florida as surety, in accordance with Section 255.05, Florida Statutes. An insufficient proposal bond surety shall automatically constitute a failure on the part of the proposer and shall be grounds for rejection of your bid.
- 3) Bidders can **hand deliver** their proposal bond in a sealed envelope to the Finance Department, Procurement Services Division, 1 East Broward Boulevard, Suite 444, Fort Lauderdale, Florida 33301-1016, before time of bid opening, with the company name, bid number and title clearly indicated on the envelope.
- 4) Bidders can **mail** their proposal bond to the Finance Department, Procurement Services Division, 1 East Broward Boulevard, Suite 444, Fort Lauderdale, Florida 33301-1016, before time of bid opening, with the company name, bid number and title clearly indicated on the envelope. **NOTE: Bond must be received in Procurement and time stamped before bid opening.**

It will be the sole responsibility of the proposer to ensure that its proposal is submitted prior to the proposal opening date and time listed. **PAPER PROPOSAL SUBMITTALS WILL NOT BE ACCEPTED. PROPOSALS MUST BE SUBMITTED ELECTRONICALLY VIA** the City's online strategic sourcing platform.

The bond shall be retained by the City as liquidated damages in the event the proposer whose bid is accepted refuses to or fails to enter into a contract for the execution of the work solicited in this RFP.

Following the full execution of a contract for the work solicited in this RFP and the successful proposer's provision of good and sufficient bonds, in the event bid security was provided by check, the amount of the bid security accompanying the successful proposer's bid will be refunded to the successful proposer, or in the event bid security was provided by a bond, the bond accompanying the successful proposer's bid will be returned to the successful proposer. In the event the successful proposer fails to enter into, execute, and deliver a contract and furnish the required bonds within ten (10) days after the City provides notice to the

successful proposer to deliver the executed contract and the required bonds, the bid bond shall immediately be payable to the City of Fort Lauderdale.

Additional insurance and bonds may be required for the construction phase of the project.

3.10 Certified Checks, Cashier's Checks and Bank Drafts

These **CANNOT** be submitted via the City's online strategic sourcing platform, nor are their images allowed to be uploaded and submitted with your electronic bid. These forms of securities, as well as hard copy bid bonds, must be received on or before the Invitation to Bid (ITB) opening date and time, at the Finance Department, Procurement Services Division, 1 East Broward Boulevard, Suite 444, Fort Lauderdale, Florida 33301-1016, with the bid number and title clearly indicated on the envelope.

3.11 Performance and Payment Bond (Surety Bond)

The DBF shall execute and record in the public records of Broward County, Florida, a payment and performance bond in an amount at least equal to the Contract Price with a surety insurer authorized to do business in the State of Florida as surety, ("Bond"), in accordance with [Section 255.05, Florida Statutes](#) (2023), as may be amended or revised, as security for the faithful performance and payment of all of the DBF's obligations under the Contract Documents.

The successful bidder shall furnish a performance and payment bond in compliance with Section 255.05, Florida Statutes (2023), written by a Corporate Surety company, holding a Certificate of Authority from the Secretary of the Treasury of the United States as acceptable sureties on federal bonds, in an amount equal to the total amount payable by the terms of the contract, executed and issued by a Resident Agent licensed by and having an office in the State of Florida, representing such Corporate Surety, conditioned for the due and faithful performance of the work, and providing in addition to all other conditions, that if the DBF, or his or its subcontractors, fail to duly pay for any labor, materials, or other supplies used or consumed by such Contractor, or his or its subcontractor or subcontractors, in performance of the work contracted to be done, the Surety will pay the same in the amount not exceeding the sum provided in such bonds, together with interest at the rate of fifteen percent (15%) per annum, and that they shall indemnify and hold harmless the City of Fort Lauderdale to the extent of any and all payments in connection with carrying out of the contract, which the City may be required to make under the law.

The DBF is required at all times to have a valid surety bond in force covering the work being performed. A failure to have such bond in force at any time shall constitute a default on the part of the DBF. A bond written by a surety, which becomes disqualified to do business in the State of Florida, shall automatically constitute a failure on the part of the DBF to meet the above requirements.

Such bond shall continue in effect for one (1) year after completion and acceptance of the work with liability equal to at least twenty-five percent (25%) of contract price, or an additional bond shall be conditioned that the DBF will correct any defective or faulty work or material which appear within one (1) year after completion of the contract, upon notification by the City, except in contracts which are concerned solely with demolition work, in which cases twenty-five percent (25%) liability will not be applicable.

3.12 Insurance Requirements

As a condition precedent to the effectiveness of this Agreement, during the term of this Agreement and during any renewal or extension term of this Agreement, Contractor, at its sole expense, shall provide insurance of such types and with such terms and limits as noted below. Providing proof of and maintaining adequate insurance coverage are material obligations of Contractor. Contractor shall provide the City a certificate of insurance evidencing such coverage. Contractor's insurance coverage shall be primary insurance for all applicable policies, in respect to the City's interests. The limits of coverage under each policy maintained by Contractor shall not be interpreted as limiting Contractor's liability and obligations under this Agreement. All insurance policies shall be through insurers authorized or eligible to write policies in the State of Florida and possess an A.M. Best rating of A-, VII or better, subject to approval by the City's Risk Manager.

The coverages, limits, and/or endorsements required herein protect the interests of the City, and these coverages, limits, and/or endorsements shall in no way be relied upon by Contractor for assessing the extent or determining appropriate types and limits of coverage to protect Contractor against any loss exposures, whether as a result of this Agreement or otherwise. The requirements contained herein, as well as the City's review or acknowledgement, are not intended to and shall not in any manner limit or qualify the liabilities and obligations assumed by Contractor under this Agreement.

The following insurance policies and coverages are required:

Commercial General Liability

Coverage must be afforded under a Commercial General Liability policy with limits not less than:

- \$5,000,000 each occurrence and \$5,000,000 aggregate for Bodily Injury, Property Damage, and Personal and Advertising Injury
- \$5,000,000 each occurrence and \$5,000,000 aggregate for Products and Completed Operations

Policy must include coverage for contractual liability and independent contractors.

The City, a Florida municipality, its officials, employees, and volunteers are to be covered as an additional insured with a CG 20 26 04 13 Additional Insured – Designated Person or Organization Endorsement or similar endorsement providing equal or broader Additional Insured Coverage with respect to liability arising out of activities performed by or on behalf of Contractor. The coverage shall contain no special limitation on the scope of protection afforded to the City, its officials, employees, and volunteers.

Professional Liability

Coverage must be afforded for Wrongful Acts in an amount not less than \$5,000,000 each claim and \$5,000,000 aggregate.

Contractor must keep the professional liability insurance in force until the third anniversary of expiration or early termination of this Agreement or the third anniversary of acceptance of work by the City, whichever is longer, which obligation shall survive expiration or early termination of this Agreement.

Pollution and Remediation Legal Liability (Hazardous Materials)

For the purpose of this section, the term “hazardous materials” includes all materials and substances that are designated or defined as hazardous by Florida or federal law or by the rules or regulations of Florida or any federal agency. If work being performed involves hazardous materials, Contractor shall procure and maintain any or all of the following coverages (which will be specifically addressed upon review of exposure):

Contractors Pollution Liability Coverage

For sudden and gradual occurrences and in an amount not less than \$1,000,000 per claim arising out of this Agreement, including but not limited to, all hazardous materials identified under the Agreement.

Business Automobile Liability

Coverage must be afforded for all Owned, Hired, Scheduled, and Non-Owned vehicles for Bodily Injury and Property Damage in an amount not less than \$1,000,000 combined single limit each accident.

If Contractor does not own vehicles, Contractor shall maintain coverage for Hired and Non-Owned Auto Liability, which may be satisfied by way of endorsement to the Commercial General Liability policy or separate Business Auto Liability policy.

Crane and Rigging Liability

Coverage must be afforded for any crane operations under the Commercial General or Business Automobile Liability policy as necessary, in line with the limits of the associated policy.

Workers' Compensation and Employer's Liability

Coverage must be afforded per Chapter 440, Florida Statutes. Any person or entity performing work for or on behalf of the City must provide Workers' Compensation

insurance. Exceptions and exemptions will be allowed by the City's Risk Manager, if they are in accordance with Florida Statute.

Contractor waives, and Contractor shall ensure that Contractor's insurance carrier waives, all subrogation rights against the City, its officials, employees, and volunteers for all losses or damages. The City requires the policy to be endorsed with WC 00 03 13 Waiver of our Right to Recover from Others or equivalent.

Contractor must be in compliance with all applicable State and federal workers' compensation laws, including the U.S. Longshore and Harbor Workers' Compensation Act and the Jones Act, if applicable.

Insurance Certificate Requirements

- a. Contractor shall provide the City with valid Certificates of Insurance (binders are unacceptable) no later than ten (10) days prior to the start of work contemplated in this Agreement.
- b. Contractor shall provide to the City a Certificate of Insurance having a thirty (30) day notice of cancellation; ten (10) days' notice if cancellation is for nonpayment of premium.
- c. In the event that the insurer is unable to accommodate the cancellation notice requirement, it shall be the responsibility of Contractor to provide the proper notice. Such notification will be in writing by registered mail, return receipt requested, and addressed to the certificate holder.
- d. In the event the Agreement term or any surviving obligation of Contractor following expiration or early termination of the Agreement goes beyond the expiration date of the insurance policy, Contractor shall provide the City with an updated Certificate of Insurance no later than ten (10) days prior to the expiration of the insurance currently in effect. The City reserves the right to suspend the Agreement until this requirement is met.
- e. The Certificate of Insurance shall indicate whether coverage is provided under a claims-made or occurrence form. If any coverage is provided on a claims-made form, the Certificate of Insurance must show a retroactive date, which shall be the effective date of the initial contract or prior.
- f. The City shall be covered as an Additional Insured on all liability policies, with the exception of Workers' Compensation and Professional Liability.
- g. The City shall be granted a Waiver of Subrogation on Contractor's Workers' Compensation insurance policy.
- h. The title of the Agreement, Bid/Contract number, event dates, or other identifying reference must be listed on the Certificate of Insurance.

The Certificate Holder should read as follows:

City of Fort Lauderdale
100 N. Andrews Avenue
Fort Lauderdale, FL 33301

Contractor has the sole responsibility for all insurance premiums and shall be fully and solely responsible for any costs or expenses as a result of a coverage deductible, co-insurance penalty, or self-insured retention; including any loss not covered because of the application of such deductible, co-insurance penalty, self-insured retention, or coverage exclusion or limitation. Any costs for adding the City as an Additional Insured shall be at Contractor's expense.

If Contractor's primary insurance policy/policies do not meet the minimum requirements as set forth in this Agreement, Contractor may provide evidence of an Umbrella/Excess insurance policy to comply with this requirement.

Contractor's insurance coverage shall be primary insurance in respect to the City's interests, a Florida municipality, its officials, employees, and volunteers. Any insurance or self-insurance maintained by the City shall be non-contributory.

Any exclusion or provision in any insurance policy maintained by Contractor that excludes coverage required in this Agreement shall be deemed unacceptable and shall be considered breach of contract.

All required insurance policies must be maintained until the Agreement work has been accepted by the City, or until this Agreement is terminated, whichever is later. Any lapse in coverage may be considered breach of contract. In addition, Contractor must provide to the City confirmation of coverage renewal via an updated certificate of insurance should any policies expire prior to the expiration of this Agreement. The City reserves the right to review, at any time, coverage forms and limits of Contractor's insurance policies.

Contractor shall provide notice of any and all claims, accidents, and any other occurrences associated with this Agreement to Contractor's insurance company or companies and the City's Risk Management office as soon as practical.

It is Contractor's responsibility to ensure that any and all of Contractor's independent contractors and subcontractors comply with these insurance requirements. All coverages for independent contractors and subcontractors shall be subject to all of the applicable requirements stated herein. Any and all deficiencies are the responsibility of Contractor. The City reserves the right to adjust insurance limits from time to time at its discretion with notice to Contractor.

NOTE: CITY PROJECT NUMBER, PROJECT NAME AND BID NUMBER MUST APPEAR ON EACH CERTIFICATE, AND THE CITY OF FORTLAUDERDALE MUST BE NAMED ON THE CERTIFICATE AS AN "ADDITIONAL INSURED" ON REQUIRED LIABILITY POLICIES.

A Sample Insurance Certificate shall be included with the proposal to demonstrate the firm's ability to comply with insurance requirements. Provide a previous certificate or other evidence listing the insurance companies' names for all required coverage, and the dollar amounts of the coverage.

3.13 Loss Control/Safety

Precaution shall be exercised at all times by the Contractor for the protection of all persons, including employees, and property. The Contractor shall comply with all laws, regulations, or ordinances relating to safety and health, and shall make special effort to detect hazardous conditions and shall take prompt action where loss control/safety measures should reasonably be expected.

The City may order work to be stopped if conditions exist that present immediate danger to persons or property. The Contractor acknowledges that such stoppage will not shift responsibility for any loss or damages from the Contractor to the City.

3.14 Invoices/Payment

A payment schedule based upon agreed upon deliverables may be developed with the awarded vendor.

The DBF shall submit a proposed schedule of values, after contract award, in a form acceptable to the City and will be required to be approved by the City before any design Work on this Project can commence. The proposed schedule of values shall be broken into two phases for the design and the construction.

During the design phase, the DBF may submit a request for payment monthly based upon percentage of completion of the final plans and specifications. Payment during the construction phase will be based upon percentage of work/inspections completed for each item in the approved schedule of values. DBF requisition for payment shall show a complete breakdown of the Project components, and the amount due, together with such supporting evidence, as may be required by the Project Manager (PM).

The City agrees that it will pay the DBF per Florida Statutes 218.735. If, at any time during the contract, the City shall not approve or accept the DBF's work product, and an agreement cannot be reached between the City and the DBF to resolve the problem to the City's satisfaction, the City shall negotiate with the DBF on a payment for the work completed and usable to the City. This negotiated payment shall be based on the overall task or project breakdown, relative to the percentage of work completed.

Payment of invoices from the DBF shall be retained by the City per Florida Statute 255.078, until the Project has obtained Final Completion, receipt of as-built, and been accepted by the City.

3.15 Periodic Estimate for Partial Payment

After the Contractor has submitted a periodic estimate for partial payment, approved and certified by the Public Works Department, the City shall make payment in the

manner provided in the Contract Documents and in accordance with Florida's Prompt Payment Act, Section 218, Florida Statutes.

3.16 Related Expenses/Travel Expenses

All costs including travel are to be included in your bid/proposal. The City will not accept any additional costs.

3.17 Payment

The City shall make payment to the Contractor by check.

3.18 Price Proposal

A total Price Proposal (proposed Contract Price) shall be submitted on the Price Proposal Form. The Price Schedule breakdown shall consist of a Not-To-Exceed, Guaranteed Maximum Price (GMP) amount. The Price Proposal shall be based upon and include any and all costs or expenses to be incurred by the DBF in implementing, fulfilling and completing all aspects of the Design-Build Project. The information must include, but is not limited to, the design, plans approval, permitting, construction and activation of the project in accordance with the requirements set forth in the City's Request for Proposals and the requirement of any and all agencies or organizations having jurisdiction for project review, permit approval or the design, construction, occupancy, activation, use or operation of the project, or use of the property on which the project is located.

The Price Proposal, in addition to all direct costs and expenses, shall include all other indirect costs and expenses including but not limited to, such costs as the Design-Builder's general, administrative and overhead costs, project management and supervisory costs, all fees, taxes, labor, direct and indirect payroll costs, insurance and bond costs, cost of equipment, materials, tools, transportation, and service fee (profit).

3.19 Bid Allowance/Reimbursable

Allowance for Permits: Payments will be made to the DBF based on the actual cost of permits upon submission of paid permit receipts. The City shall not pay for other costs related to obtaining or securing permits.

The amount indicated is intended to be sufficient to cover the entire project. If the City Permit fees exceed the allowance indicated, the City will reimburse the contractor the actual amount of City Permit Fees required for project completion.

Allowance	\$
Permit Fee	\$75,000
Owner's Contingency	\$100,000
TOTAL	\$175,000

3.20 Contract Time

The Contractor recognizes that TIME IS OF THE ESSENCE. The Work shall commence within **30** calendar days of the date of the Notice to Proceed.

The Work shall be Substantially Completed within **365** calendar days after the date when the Contract Time commences to run as provided in the Notice to Proceed.

The Work shall be finally completed on the Final Completion Date and ready for final payment in accordance with this Agreement within **395** calendar days after the date when the Contract Time commences to run as provided in the Notice to Proceed.

3.21 City Project Manager

The Project Manager is hereby designated by the City as **Justin Murray**, whose address is 1765 SE 18th St, Fort Lauderdale, FL 33316, telephone number: (954) 828-4122, and email address is jmurray@fortlauderdale.gov. The Project Manager will assume all duties and responsibilities and will have the rights and authorities assigned to the Project Manager in the Contract Documents in connection with completion of the work in accordance with this Agreement.

For information or questions concerning technical specifications, please utilize the Question/Answer platform provided by the City's online strategic sourcing platform at the City's online strategic sourcing platform. Questions of a material nature must be received prior to the cut-off date specified in the solicitation.

3.22 Liquidated Damages

Upon failure of the DBF to substantially complete the entire Contract within the total specified period of time, plus approved time extension, DBF shall pay to the City the sum of **One Thousand and 00/100 Dollars (\$1,000)** for each and every calendar day that the completion of the work is delayed beyond the time specified in this Agreement for completion.

The time frame for liquidated damages shall not commence and thus shall not be tolled until the Project Manager submits the punch list to the DBF. These amounts are not penalties but are liquidated damages to City for its inability to obtain full beneficial use of the Project. Liquidated damages are fixed and agreed upon between the parties, recognizing the impossibility of precisely ascertaining the amount of damages that will be sustained by the City as consequence of such delay.

3.23 Public Entity Crimes

In accordance with the Public Crimes Act, Section 287.133, Florida Statutes (2023), as may be amended or revised, a person or affiliate who is a contractor, consultant or other provider, who has been placed on the convicted vendor list following a conviction for a public entity crime may not submit a bid on a contract to provide any goods or services to the City, may not submit a bid on a contract with the City for the construction or repair of a public building or public work, may not submit bids on leases of real property to the City, may not be awarded or perform work as a

contractor, supplier, subcontractor, or consultant under a contract with the City, and may not transact any business with the City in excess of the threshold amount provided in Section 287.017, Florida Statutes (2023), as may be amended or revised, for category two purchases for a period of thirty-six (36) months from the date of being placed on the convicted vendor list. Violation of this section by the Contractor shall result in cancellation of the City purchase and may result in Contractor debarment.

3.24 Subcontractors

3.24.1 If the Contractor proposes to use subcontractors in the course of providing these services to the City, this information shall be a part of the bid/proposal response. Such information shall be subject to review, acceptance, and approval of the City, prior to any contract award. The City reserves the right to approve or disapprove of any subcontractor candidate in its best interest and to require Contractor to replace subcontractor with one that meets City approval.

3.24.2 Contractor shall ensure that all of Contractor's subcontractors perform in accordance with the terms and conditions of this Contract. Contractor shall be fully responsible for all of Contractor's subcontractors' performance, and liable for any of Contractor's subcontractors' non-performance and all of Contractor's subcontractors' acts and omissions. Contractor shall defend, at Contractor's expense, counsel being subject to the City's approval or disapproval, and indemnify and hold harmless the City and the City's officers, employees, and agents from and against any claim, lawsuit, third-party action, or judgment, including any award of attorney fees and any award of costs, by or in favor of any Contractor's subcontractors for payment for work performed for the City.

3.24.3 Contractor shall require all its subcontractors to provide the required insurance coverage as well as any other coverage that the contractor may consider necessary, and any deficiency in the coverage or policy limits of said subcontractors will be the sole responsibility of the contractor.

3.25 Work Schedule

Monday – Friday 8:00 am – 5:00 pm. City Inspector hours are 8:00 a.m. to 4:30 p.m. Any inspection requested by the DBF outside those hours will be considered overtime to be paid by the DBF.

Inspection Overtime Cost: \$100/hr.

3.26 Contract

The proposer to whom award is made shall execute a written contract to do the work and maintain the same in good repair until final acceptance by the proper authorities and shall furnish good and sufficient bonds as specified within ten (10) days after receiving such contract for execution. If the proposer to whom the first award is made fails to enter into a contract as provided, the award may be annulled and the contract let to the next lowest bidder who is reliable, responsible, and responsive in the

opinion of the City, and that proposer shall fulfill every stipulation and obligation as if such proposer were the original party to whom award was made.

****END OF SECTION 3****

SECTION 4 SCOPE OF WORK

4.1 Project Objective

The City has issued this Request for Proposal (RFP) to solicit competitive proposals for a highly qualified, experienced, and licensed Design Build Firm (DBF) to provide design-build services for the design, permitting, construction, testing and startup of renovations to the Sludge Holding Tank and Pretreatment Buildings, and replacement of odor control equipment on the Sludge Holding Tank and Pretreatment Buildings' exterior at the George T. Lohmeyer Wastewater Treatment Plant in accordance with the terms, conditions, and specifications for the Project (PROJECT).

This project is located at George T. Lohmeyer Wastewater Treatment Plant, 1801 Eisenhower Boulevard, 33316, in the City of Fort Lauderdale. The work to be accomplished under this contract includes, but is not limited to: demolition, replacement of odor control equipment, roof and pipe replacement, exterior painting, interior painting, lighting replacement, flooring replacement, kitchen and locker room remodeling, addition of walkable aluminum covers for wastewater channels and basins, concrete repair, fiberglass ductwork, electrical design and construction of new unitized substations and motor control centers.

Included in the scope of work are design, permitting and construction, construction management services, as well as inspection, construction certification and all associated work delineated herein or determined by the DBF as required to meet the Project intent. The RFP Documents, including the DCP, Technical Specifications, all exhibits and attachments, and the successful proposal, shall form the terms and conditions of the Contract.

The DBF shall be responsible for designing, surveying, geotechnical exploration, preparation of completed permit submittal packages and procurement of all required permits for construction, construction phasing, maintenance of traffic and all other related work or services.

4.2 Project Background

The Pretreatment Building includes screening and grit removal, spare parts storage, break room/kitchen, locker rooms, and electrical/control rooms. The site is constrained in an urban environment with development on all sides of the facility which requires compliance with strict noise and vibration abatement requirements.

The Sludge Holding Tanks were originally floating cover digesters that were constructed at different times. They currently function as WAS holding tanks that are used to decant water from the tanks through the valves on the side of the tanks to the Plant Drain System. Thickened WAS is then pumped from the bottom of the tanks east to the dewatering facility.

4.3 Project Scope

The selected DBF shall perform the complete design, permitting, and construction of all aspects of the Project to fulfill the intent of the Project as described in the Design Criteria Package (DCP) and all supporting documents. Included in the Project is the acquisition of all tools, equipment, materials, and other supplies including but not limited to fuel, power, water, and communication devices required to complete the Project. The work also includes the performance of all labor, work, and other operations required to complete the Project. All work must be complete with all work, materials, and services not directly specified in the Contract Documents but necessary for the completion of the Project to fulfill the intent of the City performed and installed by the DBF at no additional cost to the City above what is agreed upon in the Contract Documents.

PROJECT shall include:

The work is composed of two main areas in the Pretreatment Building and the Sludge Holding Tanks. Additional details can be found in the DCP drawings. Where details are omitted, the Design Team should present the Owner with options to accomplish the following numbered primary needs.

4.3.1 Pretreatment Building

1. Replacement of the current odor control system with one capable of removing odorous air from a total of 2 locations on the 3rd floor (1 interior and 1 exterior) where turbulence causes the greatest release of odors. New odor control system will be placed in the same footprint as existing. Odor control system should have a 3-year complete warranty, not contain any hazardous chemicals, and be capable of 99% reduction of Hydrogen Sulfide and other odorous gases as measured before and after construction. Currently a sodium nitrate solution is injected into the collection system, and it is anticipated that this will continue throughout construction. The existing odor control system is currently mothballed. All ductwork is being replaced with new fiberglass duct.
2. Replacement of all hatch and tank covers on the 3rd floor interior and exterior with walkable aluminum covers designed to be sealed to the concrete and keep odors within the wastewater channels and tanks. The design was based around Hallsten covers but equivalent alternatives will be allowed.
3. Replacement of grit removal equipment and piping with a high-performance grit separation and washing system that is capable of producing grit with less than 3% organic material and dry weight of the grit should be a minimum of 90% Total Solids. New equipment will be placed in the same footprint as existing with some equipment left in service during construction. The basis of design was SAVECO FSM SWA-40 but equivalent alternatives will be allowed.

4. Renovation of the kitchen/break room, locker room facilities, and janitor's closet.
5. Design and installation of a fire alarm system in the building serving all 3 floors.
6. Replacement of the building utilities to provide water, sewer, and electrical supply to the Pretreatment Building.
7. Replacement of the MCC's and main feeders, PLC's, and Unitized Substations that power and control the building systems.
8. Replacement of field instrumentation and all conduit and conductors feeding them for the entire building. Aluminum conduit is specified throughout this project.
9. Replacement of the asphalt roof membrane of the building with thermoplastic polyolefin (TPO) roofing.
10. Addition of a large, illuminated facility sign on the west side of the building.

4.3.2 Sludge Holding Tanks

1. One new odor control system capable of removing odorous air from 2 locations (1 on each of the 2 Sludge Holding Tanks) similar to the existing ductwork. The new odor control system will be located in the same footprint as the existing. No maintenance of operations is required for the existing odor control. Odor control system should have a 3-year complete warranty, not contain any hazardous chemicals, and be capable of 99% reduction of Hydrogen Sulfide and other odorous gases as measured before and after construction.
2. Replacement of the existing steel floating covers with flat, walkable aluminum covers or an aluminum domed cover with space to walk around it 360 degrees. The selected cover should be capable of openings for inspection and designed to be sealed to the concrete and keep odors within the tanks and removed by the odor control system. Non-potable water sprays should be affixed to the inside of the cover or top walls of the tanks for weekly washdown and reachable in order to be easily maintained. The basis for design was Hallsten but equivalent alternatives will be allowed. All ductwork is to be replaced with new fiberglass duct.
3. Replacement of the building utilities to provide non-potable water to the tanks. Demolish the potable water system in the building.
4. Replacement of all field instruments and conduits and wiring.

5. Replacement of the asphalt roof membrane of the building between the tanks with thermoplastic polyolefin (TPO) roofing.
6. Replacement of Waste Activated Sludge (WAS) process piping, fittings and valves/actuators attached to the tanks' exterior.
7. Extension of the decant pipe in Manhole #15 down into the flow to minimize turbulence and odors and complete manhole restoration.

Additional to the designing, permitting, and construction of the Project, the DBF shall perform inspections, construction certification, construction management, public involvement, and all associated work described in the DCP or as determined necessary by the DBF and confirmed by the City to fulfill the Project's intent. The terms and conditions of the contract shall consist of the RFP documents including the DCP with all exhibits and attachments in addition to the proposal accepted by the City.

The DBF will be responsible for the complete design, surveying, permit submittal packages and procurement of all required construction permits that have not been previously acquired by the CITY, construction phasing, dewatering, maintenance of traffic, public involvement, and all other related work/services.

The DCP conveys the minimum requirements of the CITY regarding the design, construction, maintenance of traffic operations, management, and scheduling of the PROJECT including any scheduling and coordination with local, county, and state governments and regulating agencies necessary to obtain permits for construction.

4.4 Project Requirements

The selected DBF must use effective project management practices while working on the Project. Included in project management is clear communication with the City and other parties involved in the Project, management of time and resources, and documentation of all services and communication. Contract administration and technical reviews of all work pertaining to the Project will be performed by the City.

4.4.1 Design and Construction Criteria

The selected DBF shall take a comprehensive and thorough technical approach to completing the design-build operation outlined for the Project, and the minimum requirements set forth in the DCP in Exhibit A and technical requirements incorporated herein as Exhibit B. Submitted technical proposals must convey that the DBF has a complete understanding of the Project, its intent, and City objectives. Additionally, the technical proposal shall address the following items:

1. Completion of engineering design plans for construction. DBF shall submit conceptual (30%), 60% design package, and a 90% design

package for review by the City. City review comments shall be incorporated into the final design package.

2. Procurement of all required construction permits from local, state, and federal agencies including but not limited to the Florida Department of Transportation, Florida Department of Environmental Protection, South Florida Water Management District, Broward County Environmental Protection and Growth Management Department, Broward County Traffic Engineering Division, Broward County Health Department, and the City of Fort Lauderdale. The DBF must develop permitting strategies and determine possible issues, testing requirements, and timing for the Project.
3. Identification of appropriate quality control/quality assurance measures to be performed for the Project.
4. Production of signed and sealed record drawings following completion of construction of the Project.

4.4.2 Governing Regulations

The selected DBF shall provide services in compliance with State of Florida Building Code (FBC) 7th Edition (2020), composed of modified adopted versions of the 2018 editions of the International Building Code (IBC); the Florida Building Code, Existing Building; International Plumbing Code (IPC); International Mechanical Code (IMC); International Fuel Gas Code (IFGC); International energy Conservation Code (IECC); 2017 edition of the National Electric Code; ASCE 7-16 and current ASHRAE standards, with all appendices, references and supplements incorporated. Additional compliance with all regulations and requirements of local and service district utility companies (electric, fiber optic, phone, gas, water, sewerage, and drainage) where work is to be located is required.

1. Electrical Systems
Electrical work within the affected program area shall be in compliance with current and applicable sections of the 2017 Edition of the National Electrical Code, state and local requirements, County standards and good engineering practice.
2. Fire Code
The 7th Edition (2020) of the Florida Fire Prevention Code, which is based on NFPA 1, Fire Code, 2018 edition, NFPA 101, Life Safety Code, 2018 edition, and it references a variety of other NFPA editions.
3. Accessibility

Regulations Governing Construction of Facilities for persons with disabilities by the 7th Edition (2020) of the State of Florida Accessibility Code, the Fair Housing Amendment Act (1988) and the Americans with Disabilities Act (1990) or other Federal regulations, where applicable.

4. Telecommunications Systems

Voice, data, and video systems serving affected areas shall be in compliance with the latest editions and the applicable sections of EIA/TIA, IEEE, BISCI (Building Industry Consulting International Telecommunications Distribution Methods Manual), NFPA 70 (National Electrical Code), VESA (Video Electronics Standards Association), City standards and good engineering practice.

4.4.3 Standards

The remodeling work for the project shall be designed to comply with the latest prevailing material standards and guidelines.

General Requirements

1. Building design and construction materials for the new sign on the Pretreatment Building shall be in accordance with the requirements of the Florida Building Code and as specified herein. The design shall be prepared and sealed by an Architect licensed in the State of Florida. Work pertaining to engineering shall be prepared by Engineers of appropriate disciplines licensed in the State of Florida.
2. The City Standards represent items or systems used throughout the City for ease of maintenance and require prior City Authorization to make any changes or deviations.
3. Design elements should enhance the form and function of the structure and surrounding areas as well as comply with all local standards.
4. The design of this project scope shall be developed in such a way to cause the least amount of disruption to the existing water plant and adjacent neighboring operations.
5. Selection of building materials and systems shall be suitable for low maintenance and energy efficiency.
6. Any exterior improvements shall fully comply with the high velocity hurricane zone wind loads for Broward County.

4.4.4 Materials of Construction

The standard for materials of construction on this project shall be 316 SS or marine-grade aluminum, including all hardware. Deviations from the standard must be approved by the City in writing. Installed inferior materials without prior approval may be required to be removed and replaced at the

City's discretion. Requests for deviations must be clearly marked on submittals.

4.5 Services and Materials Provided by the City

A project manager will represent the City as the technical representative of the Project.

1. Copies of the available Record Drawings of the G.T. Lohmeyer WWTP upon request
2. Design Review
3. Submittal Review after EOR approval
4. Construction observation and inspection of the Project as deemed appropriate by the City
5. Assistance with MOPO

4.6 Existing Underground Utility Information

There are existing underground utilities in the Project site. Limited information on the location of these utilities has been provided in the DCP. The City does not assume responsibility for the accuracy of the provided existing underground utility documents or liability if the locations of these utilities differ from the documents provided. It is the responsibility of the DBF to confirm the actual location of existing underground utilities.

4.7 CADD Standards

All submitted design drawings for the Project shall meet the standards set by the City in the "City of Fort Lauderdale Public Works Engineering & Architectural Department CADD Specifications for Project Drawings" (hereinafter referred to as City CADD Standards). The selected DBF will comply with the most recent edition of the City CADD Standards in place at the time of contract execution. A copy of the City CADD Standards will be provided by the City upon request.

4.8 Provisions for Utilities, Dewatering, Staging and Parking

The selected DBF will be required to pay for all utilities needed for the completion of the Project.

The selected DBF shall only perform dewatering activities after acquiring all applicable permits from regulating agencies with jurisdiction in the Project area. Any dewatering operations performed by the DBF must meet the conditions of applicable permits. Any dewatering activities performed by the DBF without proper permits or without meeting permit conditions may result in punitive actions to the DBF by the City and Broward County.

The selected DBF will be responsible for the coordination of parking and staging area with the City prior to mobilization of equipment and crews into the area. Parking

and staging areas must remain free of any form of refuse and the removal of any remaining refuse will be the responsibility of the selected DBF.

4.9 Project Meetings

The City shall require meetings throughout the Project which require the participation of the City, selected DBF all subcontractors, all subconsultants, representatives of governmental agencies with jurisdiction in the Project area, and any others as requested by the City and/or DBF. All meetings shall be held onsite with a Teams or Zoom connection provided by the DBF.

Following the written Notice to Proceed, the DBF shall coordinate with the City to hold a pre-construction meeting. All following meetings shall likewise be organized by the DBF upon instruction from the City. The City or its representative shall prepare meeting minutes.

4.10 Construction Duration

Time is of the essence for the DBF's performance of the Work. The selected DBF is expected to complete the Project as expeditiously as possible. At minimum, the selected DBF must adhere to the following proposed schedule as set by the City:

MILESTONE	CALENDAR DAYS FROM NOTICE TO PROCEED
Assumed Notice to Proceed Date	TBD
Substantial Completion of PROJECT	365
Final Completion of PROJECT	395

Within seven (7) calendar days after notification of award and as a condition precedent to executing the Contract, prior to the start of any work, the DBF shall submit its preliminary construction schedule to the City for approval which shall be consistent with the Schedule in its Proposal. The Schedule shall be written in sufficient detail to show the chronological relationship of all major aspects of the project, including estimated starting and completion dates of various activities, design phase, procurement of materials, scheduling of equipment, and construction phase with a level of detail commensurate with the level of detail in the Proposal. The schedule is subject to approval by the City.

4.11 Permits

It is the responsibility of the DBF to apply for and obtain all permits as necessary to construct the Project.

****END OF SECTION 4****

SECTION 5

SUBMITTAL REQUIREMENTS

5.1 Instructions

5.1.1 The City uses the City's online strategic sourcing platform to administer the competitive solicitation process, including but not limited to soliciting responses, issuing addenda, posting results and issuing notification of an intended decision. There is no charge to register and download the RFP from the City's online strategic sourcing platform. Proposers are strongly encouraged to read the various vendor Guides and Tutorials available in the City's online strategic sourcing platform well in advance of their intention to submit a response to ensure familiarity with the use of the City's online strategic sourcing platform. The City shall not be responsible for a proposer's inability to submit a response by the end date and time for any reason, including issues arising from the use of the City's online strategic sourcing platform.

All proposals must be submitted electronically.

5.1.2 Careful attention must be given to all requested items contained in this RFP. Consultants are invited to submit responses in accordance with the requirements of this RFP. Please read entire solicitation before submitting a proposal. Consultants must provide a response to each requirement of the RFP. Responses should be prepared in a concise manner with an emphasis on completeness and clarity. Consultant's notes, exceptions, and comments may be rendered on an attachment, provided the same format of this RFP text is followed.

5.1.3 All information submitted by DBF shall be typewritten or provided as otherwise instructed to in the RFP. DBFs shall use and submit any applicable or required forms provided by the City and attach such to its response. Failure to use the forms may cause the response to be rejected and deemed non-responsive.

The proposer understands that the information contained in these proposal pages is to be relied upon by the City in awarding the proposed Agreement, and such information is warranted by the proposer to be true. The proposer agrees to furnish such additional information, prior to acceptance of any proposal, relating to the qualifications of the proposer, as may be required by the City.

5.1.4 Responses shall be submitted by an authorized representative of the firm. Responses must be submitted in the business entity's name by the President, Partner, Officer or Representative authorized to contractually bind the business entity. Responses shall include an attachment evidencing that the

individual submitting the response, does in fact have the required authority stated herein.

- 5.1.5** In the event of Contract award, all documentation produced as part of the Contract shall become the exclusive property of the City. The Proposer's response to the RFP is a public record pursuant to Florida law, which is subject to disclosure by the City under the State of Florida Public Records Law, Florida Statutes Chapter 119.07 ("Public Records Law"). The City shall permit public access to all documents, papers, letters or other material submitted in connection with this RFP and the Contract to be executed for this RFP, subject to the provisions of Chapter 119.07 of the Florida Statutes.

Any language contained in the Proposer's response to the RFP purporting to require confidentiality of any portion of the Proposer's response to the RFP, except to the extent that certain information is in the City's opinion a Trade Secret pursuant to Florida law, shall be void. If a Proposer submits any documents or other information to the City which the Proposer claims is Trade Secret information and exempt from Florida Statutes Chapter 119.07 ("Public Records Laws"), the Proposer shall clearly designate that it is a Trade Secret and that it is asserting that the document or information is exempt. The Proposer must specifically identify the exemption being claimed under Florida Statutes 119.07. The City shall be the final arbiter of whether any information contained in the Proposer's response to the RFP constitutes a Trade Secret. The City's determination of whether an exemption applies shall be final, and the Proposer agrees to defend, indemnify, and hold harmless the City and the City's officers, employees, and agent, against any loss or damages incurred by any person or entity as a result of the City's treatment of records as public records. In addition, the proposer agrees to defend, indemnify, and hold harmless the City and the City's officers, employees, and agents, against any loss or damages incurred by any person or entity as a result of the City's treatment of records as exempt from disclosure or confidential. Proposals purporting to be subject to copyright protection in full or in part will be rejected. The proposer authorizes the City to publish, copy, and reproduce any and all documents submitted to the City bearing copyright symbols or otherwise purporting to be subject to copyright protection.

EXCEPT FOR CLEARLY MARKED PORTIONS THAT ARE BONA FIDE TRADE SECRETS PURSUANT TO FLORIDA LAW, DO NOT MARK YOUR RESPONSE TO THE SOLICITATION AS PROPRIETARY OR CONFIDENTIAL. DO NOT MARK YOUR RESPONSE TO THE SOLICITATION OR ANY PART THEREOF AS COPYRIGHTED.

IF THE CONTRACTOR HAS QUESTIONS REGARDING THE APPLICATION OF CHAPTER 119, FLORIDA STATUTES, TO THE CONTRACTOR'S DUTY TO PROVIDE PUBLIC RECORDS RELATING TO THIS CONTRACT, CONTACT THE CUSTODIAN OF PUBLIC RECORDS AT: PRRCONTRACT@FORTLAUDERDALE.GOV, 954-828-

5002, CITY CLERK'S OFFICE, 100 NORTH ANDREWS AVENUE, FORT LAUDERDALE, FLORIDA 33301)

DBF shall:

1. Keep and maintain public records required by the City in order to perform the service.
2. Upon request from the City's custodian of public records, provide the City with a copy of the requested records or allow the records to be inspected or copied within a reasonable time at a cost that does not exceed the cost provided in Chapter 119, Florida Statutes (2023), as may be amended or revised, or as otherwise provided by law.
3. Ensure that public records that are exempt or confidential and exempt from public records disclosure requirements are not disclosed except as authorized by law for the duration of the contract term and following completion of this contract if the DBF does not transfer the records to the City.
4. Upon completion of the Contract, transfer, at no cost, to the City all public records in possession of the DBF or keep and maintain public records required by the City to perform the service. If the Contractor transfers all public records to the City upon completion of this Contract, the Contractor shall destroy any duplicate public records that are exempt or confidential and exempt from public records disclosure requirements. If the Contractor keeps and maintains public records upon completion of this Contract, the Contractor shall meet all applicable requirements for retaining public records. All records stored electronically must be provided to the City, upon request from the City's custodian of public records, in a format that is compatible with the information technology systems of the City.

5.1.6 Submittals

All technical and Price Proposals offers to this RFP, shall be submitted **electronically** via the City's online strategic sourcing platform and will be opened **electronically** via the City's online strategic sourcing platform at the date and time indicated on the solicitation. **PAPER BID SUBMITTALS WILL NOT BE ACCEPTED. BIDS MUST BE SUBMITTED ELECTRONICALLY VIA** the City's online strategic sourcing platform.

The DBF should concisely follow the format set out herein and provide all the information requested:

It is the sole responsibility of the Proposer to ensure their proposal is received on or before the date and time stated, in the specified number of copies and in the format stated herein.

5.2 Contents of Qualification Statement/Submittals:

The following information and documents are required to be provided with DBF response to this RFP. Failure to do so may deem your proposal non-responsive or non-responsible. The City deems certain documentation and information important in the determination of responsiveness/responsibility, and for the purpose of evaluating responses. Responses should seek to avoid information in excess of that requested, must be concise, and must specifically address the issues of this RFP. The following checklist is not inclusive of all the information that may be necessary to properly evaluate the response and meet the requirements of the scope of work and/or specifications. Additional documents and information should be provided as deemed appropriate by the Proposer in response to specific requirements stated herein or through the RFP.

Table of Contents

5.2.1 Proposal Contact Person Information

Indicate which firm/company is the Lead Design-Builder whose signature grants authority to bind submitter to the provisions of this RFP.

Identify the following:

- Legal name of proposer(s)
- Federal employee identification (FEIN) number
- Mailing address City State Zip
- Contact person's name
- Title
- Email address
- Phone number
- Fax number

Any firm/company qualifying as a minority entity to this RFP should also be identified in the same manner. If there are multiple firms proposed as one team, each firm must be identified.

5.2.2 Qualifications of The Firm

5.2.2.1 Minimum Qualifications

The Proposer shall have the following Minimum Qualifications to be considered eligible to submit a proposal in response to this Solicitation. It is the responsibility of the Proposer to ensure and certify that it meets the Minimum Qualifications stated below.

A Proposer not meeting all of the following criteria will have its Proposal rejected:

- Successfully completed at least two (2) collaborative delivery (Design-Build) projects in the last ten (10) years with a contract value of at least \$5,000,000.00 at a water or wastewater treatment facility.

- The Proposer shall provide evidence of bonding capacity, in the form of a letter from a surety or insurance company, on its letterhead stating that the Proposer is capable of obtaining separate performance and payment bonds to cover a minimum amount of \$10,000,000.00.

Licensure

- The Proposer shall be licensed as a General Contractor in the State of Florida at the time of submittal of its RFP shall maintain licensure for the duration of the Design-Build Contract.
- The Proposer's Engineer shall be licensed as a Professional Engineer in the State of Florida and shall maintain licensure for the duration of the Design-Build Contract.

Business Structure

- Provide a brief introduction narrative letter highlighting the qualifications of the firm in providing the professional services as it relates specifically to the Project;
- Corporations, Joint Ventures, LLC or Partnerships – submit a copy indicating when the corporation was organized as a legal entity in the State of Florida, corporation number;
- Any firm(s) involved in a joint venture in this Proposal will be evaluated individually. An executed copy of the joint venture agreement must be submitted with the proposal. Percentages of participation of fees must be clearly stated for each joint venture partner;
- Include copies of all active State of Florida professional licenses, including professional engineers, State of Florida certifications; State of Florida certified general contractors license with unlimited building classification, held by the Firm under Florida Law to provide the required services;
- Names of Key Personnel and Role in this project;
- Name, title, name of firm, phone number, fax number, and email;
- Demonstrate your firm's ability to comply with insurance requirements. Provide a previous certificate or other evidence listing the Insurance Companies' names for both Professional Liability, General Liability, Automobile Liability, Worker's Compensation, and Professional Liability and/or Errors and Omissions, evidencing the dollar amounts of the coverage.

Firm's Workload

For the prime DBF, or in the case of a Joint Venture (JV), list all completed and active projects that DBF or JV has managed within the past five (5) years. In addition, list all projected projects and dollar value that DBF or JV will be working on in the near future.

Projected projects will be defined as a project(s) that DBF or JV has been awarded a contract, but the Notice to Proceed has not been issued. Identify any projects that DBF or JV is working on concurrently and dollar value of remaining work. Describe Vendor's approach in managing these projects. Were there or will there be any challenges for any of the listed projects? If so, describe how Vendor dealt with or will deal with the projects' challenges.

Joint Ventures

If applicant is a joint venture, provide a copy of the joint venture agreement that was filed with the State of Florida. All applicants must comply with Chapter 489 Florida Statutes, as well as the Florida Administrative Code **prior to the proposal submission.**

Firm's Past Experience

Firms should submit any information they deem appropriate for evaluation of past performance with projects similar in nature to the one under consideration by the City.

- Title of example project;
- Location of example project;
- Client name/owner's representative name, address, phone number, and email;
- Date project started and completed or is anticipated to be completed; Point of contact name and organization which contracted the service who is very familiar with the project and the firm's performance and phone number and email;
- Brief description of Project relevance to this contract;
 - Original budget vs. Final cost
 - Principal elements and special features of the project.
 - Details of project value engineering; cost savings realized; innovative solutions; project time enhancement; value added efforts; etc.
 - Present status of project.

Key Personnel

The DBF shall provide a maximum of seven (7) resumes of the key staff to be assigned to perform the Work. The resumes provided shall identify the Project Manager, Design Manager, DBF or General Superintendent, Project

Quality Control Manager, Scheduler/Project Controls Specialist, Project Health and Safety Manager. These Primary positions shall only serve in one (1) role.

NOTE: The Project Manager must be an employee of the DBF or JV submitting the Proposal and not a Subconsultant or not a Subcontractor. Persons whose resumes are submitted as a Team Member must actually perform the Work unless DBF/JV receives prior approval by the City Project Manager to use a backup Team Member.

Provide an organization chart for proposed Team Member key personnel staff, including subconsultants and subcontractors.

Concerning Subconsultants, suppliers, and Others

The amount of work that is sublet by the DBF, including Joint Ventures, shall be limited by the condition that the DBF, or in the case of a Joint Ventures, shall with his own organization, perform at least **forty percent (40%)** of the total dollar amount of the Work to be performed under the Agreement.

Safety

Most recent Experience Modification Rate (EMR) (provided on letterhead from current insurance provider) not greater than 1.0; Five-year average OSHA Total Recordable Incident Rates (TRIR) of less than 3.4; Five-year average OSHA Days Away, Restricted or Transferred (DART) Rate of less than 2.1; and Five-year average OSHA Days Away from Work Case (DAWC) rate of less than 1.0.

5.2.3 Qualifications of The Team

The DBF must identify all design and construction disciplines and specialty consultants that the DBF intends to employ in the design and construction of this Project.

- Name and title of each proposed team member;
- Years' of experience;
- Area of responsibility;
- Firm name and location;
- Education – provide information on the highest relevant academic degree(s) received and areas of specialization;
- Current professional registration; license(s)
- Provide information on any other professional qualifications relating to this team member such as publications, organizational memberships, certifications, training, awards, and foreign language capabilities;

For each key personnel, a minimum of three (3) alternate delivery projects on which they held a key delivery role should be included. Resumes should clearly identify and describe the role of the Key Personnel, in each project listed. Resumes shall also identify any specialty or technical process

expertise. **Resumes shall not be more than two (2) pages each on 8.5” x 11” sized paper. No more than seven (7) resumes should be submitted.**

Sub-consultant(s)

DBF must clearly reflect in its Proposal any Sub-consultant including but not limited to the Project Manager, Design Manager, DBF or General Superintendent, Project Quality Control Manager, Scheduler/Project Controls Specialists, Project Health and Safety Manager (collectively, the “Team Members”), proposed to be utilized along with a summary of their background and qualifications, including but not limited to name of the sub-consultant, location of place of business, service(s) the sub-consultant will provide, license (if applicable), two (2) sub-consultant references, ownership, education, and experience. These primary positions shall only serve in one (1) role. The City retains the right to accept or reject any sub-consultant proposed.

5.2.4 Project Manager’s Experience

Provide a comprehensive summary of the experience and qualifications of the individual(s) who will be selected to serve as the project managers overseeing the design and construction for the City. Individual(s) must have a minimum of five (5) years’ experience in required discipline and have served as project manager on a minimum of three (3) previous occasions. Include their related work experience and qualification and copies of active licenses and certifications. Include the length of tenure with Firm.

All proposed team Project Managers must be committed for the duration of the Project and must have the City’s approval prior to replacement.

5.2.5 Example Projects

Illustrate proposed team member’s qualifications preferably where multiple team members worked together in the past five (5) years on similar projects, including projects that involve design, permitting, and construction including:

- Title and location of project
- Year started and completed
- Project owner, point of contact, point of contact phone number, and email
- Initial cost of project and actual cost at completion
- Brief description of project and relevance to this project.
- Provide organizational chart of proposed team:
Indicate names and titles of all team members and the firm they are associated with.

5.2.6 Project Methodology and Approach

- Provide a statement of the firm's understanding of the Project and methodology and approach to managing the Project. Include a plan for completing the specified work, including ability to meet time and budget requirements while demonstrating an understanding of the following design elements:
 - Maintenance of Plant Operations (MOPO) at the GTL WWTP.
 - Familiarity with the electrical and controls operation as it pertains to this project.
 - Installation methods of proposed facilities.
 - Knowledge and experience of odor control equipment.
 - Knowledge and experience of aluminum covers over various configuration of tanks.
- Provide a conceptual design for the proposed Project. Include design, construction, planning, coordination, scheduling, maintainability and any other areas that utilize new or time saving techniques to accomplish the work in a timely manner without sacrificing quality, including Maintenance of Plant Operations (MOPO);
- Describe means and methods for expediting project schedule;
- Provide information on your firm's current workload and how this Project will fit into your workload;
- Describe available facilities, technological capabilities and other available resources you offer for the project.

5.2.6 References

The DBF shall have previous experience in the design, permitting, construction aspects of the project as described in this RFP, of constructing additions/ modifications to existing water or wastewater treatment facilities in the State of Florida within the last five (5) years.

DBF shall submit proof of design, permitting, and construction experience for a minimum of three (3) projects or any information they deem appropriate for evaluation of past performance with projects similar in scope and scale (or larger) to the one under consideration; and shall, for each project listed, including but not limited to:

- Client Name, address, contact person telephone, fax numbers, and email addresses.
- Project name and overall scope.
- Dates of construction.
- Description of work that was self-performed.
- Details of project value engineering; cost savings realized; innovative solutions; project time enhancement; value added efforts; etc.
- Total cost of the construction; estimated and actual.

The DBF shall be responsible for verifying reference contact name, phone number, email addresses, and contact place of employment, submitted as proof of project experience.

Note: Do not simply include City of Fort Lauderdale work or staff as references to demonstrate your capabilities. The Committee is interested in work experience and references other than the City as well.

The proposer shall mark any pages of the submittal it considers proprietary or confidential accordingly. Proposer shall state what proprietary or confidential governing law the Proposer is claiming such relief. Information will be treated as such by the City; provided, however, that the City cannot ensure that this information would not be subject to release pursuant to a public disclosure request. If a request for such information is received, the City will promptly notify the Proposer of such request and it shall be the Proposer's sole burden and responsibility to immediately seek and obtain such injunctive or other relief from the Courts and to immediately serve notice of the same upon the party requesting the public records.

5.2.7 Price Proposal Form

Proposer must submit the Price Proposal Form included in this RFP. In addition to submitting the required Price Proposal Form, the Proposer must include a separate Schedule of Values for each phase or task of work. This Schedule of Values and Price Proposal form shall also be submitted in electronic Microsoft Excel format with detailed breakouts of pricing and supporting calculations and organizational structure. The price proposal shall be based upon and include any and all costs or expenses to be incurred by the DBF in implementing, fulfilling and completing all aspects of the design-build project. The price proposal, in addition to all direct costs and expenses, shall include all other indirect costs and expenses including but not limited to, such costs as the design-builder's general, administrative and overhead costs, project management and supervisory costs, all fees, changes and taxes, labor, direct and indirect payroll costs, insurance and bond costs, cost of equipment, materials, tools, transportation, and service fee (profit).

5.2.8 Contract Forms

All contract forms must be completed (with all blanks filled in)

a. Sample Insurance Certificate

Demonstrate your firm's ability to comply with insurance requirements. Provide a previous certificate or other evidence listing the Insurance Companies names for both Professional Liability and General Liability and the dollar amounts of the coverage.

b. Prime DBF Identification

c. Non-Collusion Statement

d. Non-Discrimination Certification Form

e. E-Verify Affirmation Statement

f. Affidavit of Compliance with Foreign Entity Laws

g. Proposal Bond

h. Price Proposal

i. Proposal Certification

5.3 Before awarding a contract, the City reserves the right to require that a firm submit such evidence of its qualifications as the City may deem necessary. Further, the City may consider any evidence of the financial, technical, and other qualifications and abilities of a firm or principals, including previous experiences of same with the City and performance evaluation for services, in making the award in the best interest of the City.

****END OF SECTION 5****

**SECTION 6
EVALUATION AND SELECTION CRITERIA**

6.1 Evaluation Criteria and Scoring (100 Percentage)

Design-Build Team’s responses to this RFP will be evaluated and ranked by an RFP Evaluation Committee. Submittals shall be evaluated based upon the information and references contained in the proposals as submitted.

CRITERIA	PERCENTAGE
Qualifications of the Firm & the Team	20
Project Methodology & Approach	50
Price Proposal	30
TOTAL	100

6.2 EVALUATION PROCEDURE

Committee

Evaluation of the submittals will be conducted by an Evaluation Committee, consisting of a minimum of three (3) members of City Staff, or other persons selected by the City Manager or designee. All committee members must be present at scheduled evaluation meetings. Submittals shall be evaluated based upon the information and references contained in the Proposals as submitted. Any firm(s) involved in a joint venture in its Proposal will be evaluated individually, as each firm of the joint venture would have to stand on its own merits.

Scoring and Ranking

The City uses a mathematical formula to determine the scoring for each individual responsive and responsible firm based on the weighted criteria stated herein. Each evaluation committee member will rank each firm by criteria, giving their first ranked firm as number 1, the second ranked firm as number 2, and so on. The lowest final ranking score will determine the recommendation by the evaluation committee to the City Manager.

Clarification

During the evaluation process, the City has the right to require any clarification it needs in order to understand the DBF’s view and approach to the project scope of the work. Any clarifications to the Proposal made before executing the contract will become part of the final DBF contract.

Negotiations

The City Manager or designee reserves the right to conduct contract negotiations with the selected responsible, responsive DBF. If successful, the DBF and City will enter into a contract for the work. All proposers are considered fully informed as to

the intentions of the City regarding the timeframe to prepare and complete contract negotiations.

If the City is unable to negotiate a satisfactory design-build contract with the design-build firm considered to be the most qualified, negotiations with that design-build firm shall be formally terminated. Upon termination of said negotiations, negotiations shall then be undertaken with the second ranked firm, with this process being repeated until an agreement is reached which is then recommended and formally approved by the City Commission or until the short-list is exhausted in which case a new RFP may be undertaken.

The City may withdraw this RFP, reject qualifications or any portion thereof at any time prior to an award, and is not required to furnish a statement of the reason why a particular qualification was not deemed to be the most advantageous to the City.

Consult Design Criteria Professional

The City shall consult with the design criteria professional who prepared the package concerning evaluation of the proposals, approval of detail work and drawings for the project and compliance of project construction with the package.

Award

The City reserves the right to award a contract to that DBF which will best serve the interest of the City. The City reserves the right, based upon its deliberations and in its opinion, to accept or reject any or all submittals. The City also reserves the right to waive minor irregularities or variations of the submittal requirements and RFP process and any informality in any proposal and to reject any or all proposals. The City reserves the right to reduce or delete any of the proposal items.

Upon award of a Contract, in accordance with Florida Statutes, by the City Commission, the City Manager is authorized to execute the Contract on behalf of the City.

At time of award of contract, the City reserves the right to set a guaranteed maximum price limit that may be expended on this project. Contract quantities of any or all items may be increased, reduced, or eliminated to adjust the contract amount to coincide with the amount of work necessary or to bring the contract value to within the established limit.

Exceptions

Any proposer that objects to any element of the solicitation documents including but not limited to the RFP, DCP, drawings, construction time frame, sample agreement, general terms and conditions, etc. should state those objections in the submittal.

****END OF SECTION 6****

SECTION 7
APPENDIX ATTACHMENTS

- A) Design Criteria Package (DCP)
- B) Drawings - Sludge Holding Tank Renovations
- C) Sludge Holding Tanks As-Built
- D) Drawings - Pre-Treatment Building

****END OF SECTION 7****



CITY OF FORT LAUDERDALE

**SECTION 8
PRICE PROPOSAL FORM**

RFP #209 - Project P12169/P12702

DESIGN-BUILD SERVICES FOR **PRE-TREATMENT BUILDING IMPROVEMENTS**

DESIGN

1. Design Development \$ _____

2. Construction Administration \$ _____

SUB-TOTAL DESIGN COSTS \$ _____

PRE-TREATMENT BUILDING IMPROVEMENTS

CONSTRUCTION

3. Mobilization/Demobilization \$ _____

4. Bonds & Insurance \$ _____

5. Odor Control System \$ _____

6. Hatch and Tank Covers \$ _____

7. Grit Removal Equipment \$ _____

8. Architectural Improvements \$ _____

9. Electrical Improvements \$ _____

10. Utility Improvements \$ _____

SUBTOTAL CONSTRUCTION COSTS \$ _____

PRE-TREATMENT BUILDING IMPROVEMENTS



CITY OF FORT LAUDERDALE

**SECTION 8
PRICE PROPOSAL FORM**

RFP #209 - Project P12252/P12255

DESIGN-BUILD SERVICES FOR SLUDGE HOLDING TANKS IMPROVEMENTS

DESIGN

1. Design Development \$ _____

2. Construction Administration \$ _____

SUB-TOTAL DESIGN COSTS \$ _____

SLUDGE HOLDING TANKS IMPROVEMENTS

CONSTRUCTION

3. Mobilization/Demobilization \$ _____

4. Bonds & Insurance \$ _____

5. Odor Control System \$ _____

6. Tank Covers \$ _____

7. Utilities Improvements \$ _____

8. Electrical Improvements \$ _____

9. Roof Membrane \$ _____

10. Waste Activated Sludge (WAS) Process Piping \$ _____

SUBTOTAL CONSTRUCTION COSTS: \$ _____

SLUDGE HOLDING TANKS IMPROVEMENTS

BID ALLOWANCES

**Permits, Licenses, and Testing Fee for Government Agencies
(for both Design and Construction) \$75,000.00**

Owner's Contingency \$100,000.00

SUBTOTAL DESIGN COSTS \$ _____

**PRE-TREATMENT BUILDING IMPROVEMENTS & SLUDGE HOLDING TANKS
IMPROVEMENTS**

SUBTOTAL CONSTRUCTION COSTS \$ _____

**PRE-TREATMENT BUILDING IMPROVEMENTS & SLUDGE HOLDING TANKS
IMPROVEMENTS**

TOTAL DESIGN BUILD PRICE \$ _____

(Design + Construction + Allowances)

TOTAL PROPOSAL – Design, Construction, and Permit Allowance Costs (proposed “Contract Price”). Enter this figure in the Item Response Form, to indicate your total price.

(AMOUNT IN WORDS)

\$

(FIGURES)

1. The prices listed in the Price Proposal Form shall include the total cost to complete the Work including but not limited to materials, labor, equipment, profit, bonds, insurances, etc., as necessary to ensure proper execution of the design-build services and product requested by the City of Fort Lauderdale. Any pricing, quantities, costs or services that are not listed above, and are known to be required, must be added by the Proposer and listed on a separate sheet and included in the total.
2. I hereby certify that I am authorized to act on behalf of the firm, individual, partnership, corporation or association making this proposal and that all statements made in this document are true and correct to the best of my knowledge. I agree to hold this proposal open for a period of one hundred and eighty (120) days from the deadline for receipt of proposals.
3. I understand and agree to be bound by the conditions contained in the Request for Proposal and shall conform with all requirements of the Request for Proposal.

This proposal is submitted by:

Corporation

Name: _____
(Please Print)

By: _____
(Signature)

Name: _____
(Typed or printed)

Title: _____

Date Submitted: _____

Address: _____

[State] Contractor's License No.: _____

Contractor's License Class: _____

CITY OF FORT LAUDERDALE

CONTRACT

Design Build Services for G. T. Lohmeyer WWTP Odor Control Improvements
Event/RFP No. 209

DESCRIPTION

CONTRACTOR

AMOUNT

COMMISSION APPROVAL DATE

Sample Agreement

AGREEMENT

Between

CITY OF FORT LAUDERDALE

And

VENDOR

for

DESIGN/BUILD SERVICES FOR G. T. LOHMEYER
WWTP ODOR CONTROL IMPROVEMENTS

REQUEST FOR PROPOSAL NO. 209

Sample Agreement

This Agreement made and entered into this _____ day of _____, 2024, between the CITY OF FORT LAUDERDALE, FLORIDA, a municipal corporation of the State of Florida, hereinafter referred to as "CITY" and **VENDOR.**, a XXXX Corporation authorized to transact business in Florida, its successors and assigns, hereinafter referred to as "DESIGN/BUILD FIRM," or collectively the "Party" or "Parties."

WITNESSETH, in consideration of the mutual terms and conditions, promises, covenants and payments hereinafter set forth, CITY and DESIGN/BUILD FIRM agree as follows:

ARTICLE 1- DEFINITIONS AND IDENTIFICATIONS

For the purposes of this Agreement and the various covenants, conditions, terms and provisions which follow, the definitions set forth below are assumed to be true and correct and are agreed upon by the Parties.

Agreement - This document, inclusive and including all exhibits and documents that are expressly incorporated by reference.

Applicable Laws - All federal, state, county, and local statutes, codes, laws, rules, regulations, ordinances, orders and standards applicable to the Project and any other such law hereafter enacted, and any rules adopted pursuant thereto, as all such laws may be amended from time to time to perform the Work.

Change Order - A written document ordering a change in the Not To Exceed Guaranteed Maximum Price or Contract Time or a material change in the Work.

CITY - The CITY (or Owner) shall mean the City of Fort Lauderdale, a Florida municipal corporation, having its principal offices at 100 North Andrews Avenue, Fort Lauderdale, Florida 33301, which is a Party hereto and/or for which this Agreement is to be performed. In all respects hereunder, CITY's performance is pursuant to CITY's position as the owner of a construction project. In the event CITY exercises its regulatory authority as a governmental body, the exercise of such regulatory authority and the enforcement of any rules, regulations, laws and ordinances shall be deemed to have occurred pursuant to the CITY's regulatory authority as a governmental body and shall not be attributable in any manner to CITY as a party to this Agreement.

CITY Commission - CITY Commission shall mean the governing and legislative body of the CITY.

CITY Manager - CITY Manager shall mean the Chief Administrative Officer of the CITY.

Construction Documents Phase - The phase in which DESIGN/BUILD FIRM will consult with Project Manager and prepare the Construction Documents for the Project, based upon the information provided in the Design Criteria Package (DCP), for review and approval of the CITY (including, without limitation, any and all applicable CITY departments) and any applicable regulatory agencies.

Construction Manager - The Construction Manager is the authorized individual or firm which is the representative of the DESIGN/BUILD FIRM, who/which will administer/manage the construction effort on behalf of the DESIGN/BUILD FIRM.

Construction Phase - The phase which constitutes DESIGN/BUILD FIRM's administration of the construction of the Project and all activities necessary for the completion of the Project.

Consultant - The person or entity who is a registered architect, professional engineer, professional land surveyor, and/or registered landscape architect having a contract with DESIGN/BUILD FIRM to provide professional services for the design of the Project, and who is licensed by the State of Florida to provide said services.

Contract Documents - This Agreement, as approved by the Mayor and CITY Commission and its exhibits, attachments and forms, any addenda, performance bond and payment bond, plans and specifications (as approved and permitted) as prepared by the DESIGN/BUILD FIRM in accordance with the information provided in the DCP, Notice of Award, Notice(s) to Proceed, and any and all agreed upon contract and/or design modifications, including but not limited to change orders; Project schedule; a schedule of values, and any additional documents the submission of which is required by this Agreement. When reference is made in the Contract Documents to publications, standards or codes issued by associations or societies, the intent shall be to specify the current or adopted edition of such publication or standard including revision and effect on the date of the issuance of all applicable permits.

Contract Time - The time between the Project Initiation Date specified in the Notice to Proceed and final completion, including any milestone dates thereof, established in the Agreement, as may be amended by Change Order.

Contract Price - The Not to Exceed Guaranteed Maximum Price agreed to between DESIGN/BUILD FIRM and the CITY. The Contract Price is not subject to increase, except as expressly allowed within the Contract Documents.

Design/Build Firm - VENDOR., its successors and assigns, is the DESIGN/BUILD FIRM selected to perform the Work pursuant to this Agreement, and is the person, firm or corporation liable for the acceptable performance of, and payment of, all legal debts pertaining to the Project. All references in the Contract Documents to third parties under contract or control of DESIGN/BUILD FIRM shall be deemed to be a reference to DESIGN/BUILD FIRM. The DESIGN/BUILD FIRM will be responsible for the provision, installation, and performance of all equipment, materials, services and Work. The DESIGN/BUILD FIRM is in no way relieved of the responsibility for the performance of all equipment furnished.

Design Criteria Package (DCP) - DCP shall mean those certain conceptual plans and specifications and performance-oriented drawings or specifications of the Project, as prepared and sealed by the Design Criteria Professional, and in compliance with the requirements of Section 287.055, Florida Statutes.

Design Criteria Professional - Design Criteria Professional shall mean the individual or entity who/which holds a current certificate as a registered engineer under Chapter 471 to practice engineering and who/which is employed by or retained by the CITY to provide professional services in compliance with the requirements of Section 287.055, Florida Statutes, and in connection with the preparation of the DCP who/which shall review and provide recommendations regarding the Construction Documents prepared by the DESIGN/BUILD FIRM for the Project, and evaluate compliance of Project construction with the DCP.

Field Order or Supplemental Instruction - A written order for minor changes or interpretations of the Contract Documents, but which does not involve a change in the Not To Exceed Price or Contract Time.

Final Completion - The date certified by the Project Manager that all conditions of the permits and regulatory agencies have been met; all construction, including corrective and punch list work, has been performed and accepted by the CITY; all administrative requirements of the Contract Documents have been completed; and CITY has received from DESIGN/BUILD FIRM all necessary documentation, as deemed required by the CITY including, but not limited to, the following: all final releases of liens, consent of surety, release of claims by DESIGN/BUILD FIRM, correct as-built drawings, a final bill of materials, executed final adjusted Change Orders, final invoice, copies of pertinent test results, correspondence, warranties, guarantees, operational manuals, spare parts, service contracts and tools.

NOT TO EXCEED PRICE (NTE) - THE MUTUALLY AGREED UPON CONTRACT PRICE TO BE PAID OF **\$XXXXXX** TO THE DESIGN/BUILD FIRM, AND THAT THE DESIGN/BUILD FIRM GUARANTEES NOT TO EXCEED, FOR ALL LABOR, EQUIPMENT, AND MATERIALS TO DESIGN, PERMITS (AS REQUIRED BY THE CONTRACT DOCUMENTS), ADMINISTER, COORDINATE, INSPECT, CONSTRUCT AND INSTALL THE PROJECT WITHIN THE CONTRACT TIME. THE DOLLAR AMOUNT SHALL INCLUDE, BUT NOT BE LIMITED TO ALL PROFIT, OVERHEAD, ON-SITE AND OFF-SITE CONDITIONS (KNOWN AND UNKNOWN) AND ADMINISTRATIVE COSTS. THE NOT TO EXCEED GUARANTEED MAXIMUM PRICE IS NOT SUBJECT TO INCREASE EXCEPT AS EXPRESSLY ALLOWED.

Holidays - Those designated non-work days as established by the CITY Commission of the CITY of Fort Lauderdale.

Notice to Proceed - One or more written notice(s) to DESIGN/BUILD FIRM issued by the Project Manager authorizing the commencement of specified Work.

Owners Representative - The individual or entity who/which holds a current certificate as a registered engineer under Chapter 471 to practice engineering and who/which is employed by or retained by the CITY to provide professional services in compliance with the requirements of Section 287.055, Florida Statutes, and who/which shall review and provide recommendations regarding the Construction Documents prepared by the DESIGN/BUILD FIRM for the Project, and evaluate compliance of Project construction with the requirements of this Agreement.

Plans and Specifications - The official graphic representations of the Project as prepared, signed and sealed by Architect/Engineer and which, upon written approval of CITY, shall become a part of the Contract Documents.

Project - The design/construction project described in the Contract Documents.

Project Manager/Contract Administrator - The employee of the CITY, or other designated individual who is herein referred to as the Project Manager, will assume all duties and responsibilities and will have the rights and authorities assigned to the Project Manager in the Contract Documents in connection with completion of the Work in accordance with this Agreement. The Project Manager, or designee, shall be the authorized agent for the CITY unless otherwise specified. The Term Project Manager and Contract Administrator are used interchangeably.

Punch List - The CITY's list of Work yet to be done or be corrected by the DESIGN/BUILD FIRM before the final completion date can be determined by the CITY.

Shop Drawings - Drawings, diagrams and schedules, and other data specially prepared by the DESIGN/BUILD FIRM or its subcontractors, sub-subcontractors, manufacturer, supplier or distributor to illustrate some portion of the Work.

Substantial Completion - The date, as certified by the Project Manager that all conditions of the permits and regulatory agencies have been met for the CITY's stated use of the Project, and all construction has been performed therein in accordance with the Contract Documents so CITY can beneficially enjoy, use or occupy and can operate it in all respects for its intended purpose.

Surety - The surety company or individual which is bound by the performance bond and payment bond with and for DESIGN/BUILD FIRM, who is primarily liable, and which surety company or individual is responsible for DESIGN/BUILD FIRM's acceptable performance of the Work under the Contract and for the payment of all debts pertaining thereto in accordance with Section 255.05, Florida Statutes.

Work - The totality of the obligations, including design, permitting, governmental entitlements, site plan approvals and construction and all other services required by the Contract Documents, whether completed or partially completed, including all labor, materials, equipment and services provided to or to be provided by DESIGN/BUILD FIRM to fulfill its obligations.

ARTICLE 2 - GENERAL PROVISIONS

- 2.1 DESIGN/BUILD FIRM hereby agrees to furnish all of the labor, materials, equipment, Work, services and incidentals necessary to complete the Project, in accordance with the Contract Documents, within the Contract Time and for the Not to Exceed Guaranteed Maximum Price.
- 2.2 Relationship of CITY and DESIGN/BUILD FIRM: The DESIGN/BUILD FIRM accepts the relationship of trust and confidence established between it and the CITY by this Agreement. The DESIGN/BUILD FIRM warrants and represents to CITY that it will furnish its best skill and judgment in performing the Work, and shall always act to further the interest of the CITY in the expeditious completion of the Project at the lowest cost to the CITY, and in strict accordance with the Contract Documents and prudent and customary construction practices.
- 2.3 By signing this Agreement, the DESIGN/BUILD FIRM accepts a fiduciary duty with the CITY and warrants and represents to the CITY that the DESIGN/BUILD FIRM: (a) has all licenses and certifications required by applicable laws; (b) is experienced in all aspects of pre-construction and construction planning for projects similar to the Project; (c) will act in the CITY's highest and best interests in performing the Work; and (d) that no employees or affiliates of the DESIGN/BUILD FIRM, including all Consultants, any sub-consultants, subcontractors, and suppliers, at any tier, have been convicted of a public entity crime, fraud, theft, and/or a property damage crime within the preceding thirty-six (36) months from the time this Agreement is executed, as required pursuant to Section 287.133, Florida Statutes.
- 2.4 Intention of Contract Documents: It is the intent of the Contract Documents to describe a functionally complete Project to be designed and constructed in accordance with the Contract Documents. Any Work, design, construction, other professional services, materials or equipment that may reasonably be inferred from the Contract Documents as being required to produce the intended result shall be supplied by the DESIGN/BUILD FIRM, whether or not

specifically called for by the Contract Documents. When words, which have a well-known technical or trade meaning are used to describe Work, such words shall be interpreted in accordance with that meaning. Reference to standard specifications, manuals, or codes of any technical society, organization or association, or to the laws or regulations of any governmental authority, whether such reference is specific or by implication, shall mean the latest standard specification, manual, code or laws or regulations in effect at the time of permit issuance. CITY shall have no duties other than those duties and obligations expressly set forth within the Contract Documents.

- 2.5 DESIGN/BUILD FIRM shall plan, record, and update, at least monthly, the design and construction schedule of the Project. The Project Schedule shall indicate the dates for the commencement and completion of the various stages of design and construction and shall be revised at least monthly and as required by the conditions of the Work. The Project Schedule shall encompass all of the work of all professions and trades necessary for the construction of the Project and shall be sufficiently complete and comprehensive to enable progress to be monitored on a weekly basis. DESIGN/BUILD FIRM shall be responsible to have available to it all materials, supplies, and appropriate personnel, trades, etc., necessary to complete the Work in accordance with the Project Schedule.

ARTICLE 3 - PROJECT MANAGER

- 3.1 The Project Manager is hereby designated by the CITY as Sylejman Ujkani, Project Manager whose address is . The Project Manager will assume all duties and responsibilities and will have the rights and authority assigned to the Project Manager in the Contract Documents in connection with completion of the Work in accordance with this Agreement.

ARTICLE 4 - CONTRACT DOCUMENTS

- 4.1 The Contract Documents shall be followed as to Work, materials and dimensions except with the Project Manager may authorize, in his/her sole discretion, and in writing, an exception.
- 4.2 Dimensions given in figures are to hold preference over scaled measurements from the drawings; however, all discrepancies shall be decided upon by the Consultant, with concurrent written notice to Contract Administrator/ Project Manager. DESIGN/BUILD FIRM shall not proceed when in doubt as to any dimension or measurement but shall seek clarification from the Consultant, with concurrent written notice to Project Manager.
- 4.3 DESIGN/BUILD FIRM shall maintain two (2) copies of the Contract Documents, one of which shall be preserved and always kept accessible at the site for the Project Manager, and/or authorized representatives.
- 4.4 The Contract Documents shall have the following order of precedence, beginning with the most important:
- A. This Agreement (Contract) and all exhibits, addendums, and amendments thereto;
 - B. Change Orders (to the extent permitted under this Agreement);
 - C. The Specifications, as approved and permitted;
 - D. The Plans, as approved and permitted;

- E. All other information provided in the DCP;
- F. CPM Project Schedule and Schedule of Values; and
- G. DESIGN/BUILD FIRM's response to the CITY's request;

ARTICLE 5 - SCOPE OF WORK

DESIGN/BUILD FIRM agrees to complete the Project generally described as (RFP) NO. 209, submitted by the DESIGN/BUILD FIRM, to provide design-build services for the NE 25th Ave 24-Inch Force Main Replacement, and NE 38th St 42-Inch FM and NE 19th Ave 24-Inch FM Replacement.

INSERT SCOPE HERE

The Project shall be construed in accordance with the requirements and provisions of said Contract Documents and for the Not to Exceed Guaranteed Maximum Price.

- 5.1 DESIGN/BUILD FIRM agrees to meet with the Project Manager or his/her respective designees at reasonable times and with reasonable notice.
- 5.2 Prior to the Final Completion of construction services under this Agreement, and as a condition precedent to final payment, there shall be established a record set of plans on reproducible vellum and a record set of Specifications, both of which shall bear the written approvals of the DESIGN/BUILD FIRM and the CITY's Project Manager. Such approval shall be indicated by the written signature of both Parties. In addition, there shall be established electronic copies on USB drives of the record set plans, non-compressed, formatted in the latest version of AutoCAD and of the record set of Specifications.
- 5.3 DESIGN/BUILD FIRM herein represents that Construction Manager, at a minimum, will provide the following services:
 - 5.3.1 At least five (5) days prior to the commencement of the construction phase of the Project, the DESIGN/BUILD FIRM will identify and provide the qualifications of a suitably qualified and experienced Construction Manager, approved by the CITY, who will be on site full time at the Project. No more than twenty percent (20%) of the proposed team can be changed and such change will require CITY approval.
 - 5.3.2 DESIGN/BUILD FIRM will use reasonable efforts to have the same Construction Manager on the Project, full time, to its conclusion, and any new representative will first be approved in writing by Project Manager before permanent assignment. Approval shall not be unreasonably withheld.
 - 5.3.3 The Construction Manager will conduct weekly meetings with the DESIGN/BUILD FIRM and its subcontractors at regular times, as previously agreed upon and approved by the Project Manager and shall issue weekly reports on the progress of the Work and the minutes of the previous meeting.
 - 5.3.4 The Construction Manager will administer the DESIGN/BUILD FIRM's Work.
 - 5.3.5 The Construction Manager shall coordinate the processing of shop drawings and

material submittals.

- 5.3.6 The Construction Manager will achieve satisfactory performance by DESIGN/BUILD FIRM and, if required, will require corrections to DESIGN/BUILD Firm's Work including, but not limited to, maintaining punch lists and observing testing.
 - 5.3.7 The Construction Manager will monitor the cost of the Project, including payment applications and the preparation thereof.
 - 5.3.8 The Construction Manager will assist in the preparation of record drawings and shall transmit to the Consultant requests for additional information concerning the design. In addition, the Project Manager shall be copied on these requests for monitoring purposes.
 - 5.3.9 The Construction Manager will observe testing, start-up activities, and commissioning of project scope as described in the DCP.
 - 5.4.10 The Construction Manager will secure all equipment brochures and warranties from the DESIGN/BUILD FIRM.
 - 5.4.11 The Construction Manager will coordinate the correction and completion of the Work including that required by the punch list.
- 5.4 DESIGN/BUILD FIRM herein represents that Consultant, at a minimum, will provide the following services:
- 5.4.1 Consultant shall perform all of the architectural and engineering services necessary to describe, detail and design the Project in accordance with the Contract Documents.
 - 5.4.2 Consultant shall design the Project so as to comply with Applicable Laws.
 - 5.4.3 Consultant shall prepare the Plans and Specifications, as well as obtain all required and necessary reviews and approvals (or take other appropriate action upon) for same, and/or other submittals including, but not limited to, shop drawings, product data, and samples.
 - 5.4.4 Consultant shall also submit the Plans and Specifications to the Owners Representative, with a copy to Project Manager, for his/her review and written approval. Owners Representative shall expeditiously review and approve the Plans and Specifications in accordance with the accepted Project Schedule. Owners Representative's approval of the Plans and Specifications shall not constitute acceptance of any design work which does not comply with Applicable Laws, information provided in the DCP, and/or with the terms of this Agreement. Except as provided herein, and to the extent limited by, the preceding sentence, the approval of the Plans and Specifications by the Owners Representative shall constitute a representation by the Owners Representative that the Project, if constructed as required by the Contract Documents, will be sufficient for its purposes. The Plans and Specifications shall include technical drawings, schedules, diagrams, and specifications setting forth in detail the requirements for construction of the Project; provide information necessary for the use of DESIGN/BUILD FIRM subcontractors and those in the building trade; and

include documents necessary for regulatory agencies and other governmental approvals.

- 5.4.5 Consultant shall prepare construction change directives, if necessary, at no additional cost to the CITY, and authorize minor changes in the Work, as provided in the Contract Documents.
- 5.4.6 Consultant shall receive and review for compliance with the Contract Documents, all written warranties and related documents required hereby to be assembled upon substantial completion and issue applications for payment performed in compliance with the requirements of the Contract Documents.
- 5.5 The approved and permitted Plans and Specifications shall constitute a representation by Consultant to CITY that the Project, if construed as required by the Contract Documents, will be sufficient for its purposes. The Plans and Specifications include technical drawings, schedules, diagrams, and specifications setting forth in detail the requirements for construction of the Project; provide information necessary for the use of DESIGN/BUILD FIRM, sub-contractors, and those in the building trade; and include documents necessary for regulatory agencies and other governmental approvals.
- 5.6 Project Manager will provide the following services:
 - 5.6.1 The Project Manager shall review applications for payment and coordinate the processing thereof with the CITY.
 - 5.6.2 The Project Manager shall monitor the schedule(s).
 - 5.6.3 The Project Manager shall track, log and review all required Project related documents and subsequently address any and all concerns with DESIGN/BUILD FIRM.
 - 5.6.4 The Project Manager shall review and observe the Work and testing thereof for conformance and compliance with the requirements of the Contract Documents.
 - 5.6.5 The Project Manager shall attend all required meetings and maintain and distribute meeting minutes.
 - 5.6.6 At all times, the Project Manager will act as liaison between the Parties to this Agreement, and the CITY's Project Manager.

ARTICLE 6 - CONTRACT TIME AND COMPLETION DATE

- 6.1 Time is of the essence for the DESIGN/BUILD FIRM's performance of the Work pursuant to this Agreement. The DESIGN/BUILD FIRM agrees to complete the Work in accordance with the approved and accepted Project Schedule and to achieve substantial completion of the Work, in accordance with this Agreement, and within the Contract Time. The DESIGN/BUILD FIRM acknowledges that failure to achieve substantial completion will result in substantial damages to the CITY, such as loss of beneficial use and/or occupancy of the Project.

- 6.2 DESIGN/BUILD FIRM shall be instructed to execute the Agreement immediately. DESIGN/BUILD FIRM shall immediately commence scheduling activities, permit applications and other preconstruction Work after the Notice to Proceed.
- 6.3 The DESIGN/BUILD FIRM shall complete the Construction Documents Phase.
- 6.4 The DESIGN/BUILD FIRM shall meet the following construction duration:

MILESTONE	CALENDAR DAYS FROM NOTICE TO PROCEED (COMPLETION DATE)
Assumed Notice to Proceed Date	XXX
Substantial Completion of PROJECT	XXX
Final Completion of PROJECT	XXX

ARTICLE 7 - LIQUIDATED DAMAGES

- 7.1 Failure of the DESIGN/BUILD FIRM to substantially complete the Project in accordance with Section 6.4 above, or meet any of the milestones as indicated in Section 6.4 above, DESIGN/BUILD FIRM shall pay to the CITY the sum of (Sxxx) for each calendar day that the completion of the Work is delayed beyond the time after the time specified in Article 6 Section 6.4 above (plus any approved time extensions at the sole discretion of the CITY) that DESIGN/BUILD FIRM fails to meet time specified in Section 6.4 above.
- 7.2 The time frame for liquidated damages shall not commence and thus shall not be tolled until the Project Manager submits the punch list to the DESIGN/BUILD FIRM.
- 7.3 DESIGN/BUILD FIRM and CITY HEREBY MUTUALLY AGREE AND ACKNOWLEDGE THAT THE LIQUIDATED DAMAGES AMOUNT SET FORTH HEREIN are not penalties but are liquidated damages to CITY for its inability to obtain full beneficial occupancy and/or use of the Project. Liquidated damages are hereby fixed and agreed upon between the Parties, recognizing the impossibility of precisely ascertaining the amount of damages that will be sustained by the CITY as a consequence of such delay, and both parties desiring to obviate any question of dispute concerning the amount of said damages and the cost and effect of the failure of DESIGN/BUILD FIRM to complete the Contract on time. Liquidated damages shall apply separately to each portion of the Work for which a time of completion is given.
- 7.4 The CITY shall have the right to deduct from or retain any compensation which may be due or which may become due and payable to the DESIGN/BUILD FIRM the amount of liquidated damages, and if the amount retained by the CITY is insufficient to pay in full such liquidated damages, the DESIGN/BUILD FIRM shall pay all liquidated damages in full. The DESIGN/BUILD FIRM shall be responsible for reimbursing the CITY, in addition to liquidated damages or other damages for delay, for all costs of engineering fees and inspection and other costs incurred in administering the construction of the Project beyond the completion date specified or beyond an approved extension of time granted to the DESIGN/BUILD FIRM whichever is later.
- 7.5 CITY is authorized to deduct liquidated damages from monies withheld due to

DESIGN/BUILD FIRM for the Work under this Agreement or as much thereof as CITY may, in its sole discretion, deem just and reasonable.

ARTICLE 8 - CHANGE OF THE CONTRACT TIME

- 8.1 The Contract Time may only be changed by a Change Order. Any claim for an extension in the Contract Time shall be based on written notice delivered to the Project Manager within five (5) days of the occurrence of the event giving rise to the claim. Any change in the Contract Time resulting from any such claim shall be incorporated in a Change Order.
- 8.2 The Contract Time will be extended in an amount equal to time lost due to delays beyond the control of the DESIGN/BUILD FIRM if a claim is made there for as provided in paragraph 8.1. Such delays shall include but not be limited to, acts or neglect by the CITY, or to fires, floods, labor disputes, abnormal weather conditions, or acts of God.
- 8.3 All time limits stated in the Contract Documents are of the essence. The provisions of this Article shall not exclude recovery for damages for delay by the DESIGN/BUILD FIRM.
- 8.4 Delays caused by or resulting from entities, contractors or subcontractors who are not affiliated with DESIGN/BUILD FIRM shall not give rise to a claim by the DESIGN/BUILD FIRM for damages for increases in material and/or labor costs.

ARTICLE 9 - CONTRACT PRICE (NOT TO EXCEED PRICE) AND METHOD OF PAYMENT

- 9.1 The Contract Price is the Not To Exceed Guaranteed Maximum Price agreed to by the DESIGN/BUILD FIRM and the CITY under this Agreement, payable to complete the Work in accordance with the Agreement and DCP, and, to the extent permitted by this Agreement, as may be increased or decreased by Change Order.
- 9.2 The Contract Price for the Project, which is also the Not to Exceed Guaranteed Maximum Price is \$XXXXXXX. This includes bonds, allowances and material change with the exception of permit fees. The CITY will reimburse actual cost of permit(s) upon submission of paid permit receipts.

INSERT PRICE PAGE HERE

- 9.3 In the event that the DESIGN/BUILD FIRM's total approved expenditures for the Project exceed the Not To Exceed Price Guaranteed Maximum Price, the DESIGN/BUILD FIRM shall pay such excess from its own funds. CITY shall not be required to pay any amount that exceeds the Not To Exceed Guaranteed Maximum Price and the DESIGN/BUILD FIRM shall have no claim against the CITY on account thereof.

9.4 METHOD OF BILLING AND PAYMENT

- 9.4.1 During the Construction Documents Phase, DESIGN/BUILD FIRM may submit a request for payment monthly based upon percentage of completion of the (final construction) Plans and Specifications. During the Construction Phase, DESIGN/BUILD FIRM may submit a request for payment thirty (30) calendar days after beginning field operations, subject to the Notice to Proceed, and every thirty (30) calendar days thereafter. Payment during the Construction Phase will be based upon percentage of work completed for each item in the approved Schedule of Values. DESIGN/BUILD FIRM's requisition for payment shall show a complete breakdown of the Project components, and the amount due, together with such supporting evidence, as may be required by the Project Manager.

At a minimum, the requisition for payment shall be accompanied by a completed certification of Work; consent of surety in the applicable amount; list of subcontractors that performed Work during the payment application period being submitted; releases of liens from the DESIGN/BUILD FIRM for the previous period being billed; releases of liens from subcontractors that have performed Work during the previous billing period unless payment for the previous period has not been received by the DESIGN/BUILD FIRM; aerials and photographs of the areas of Work for the applicable billing period; an accepted, updated Project Schedule (as approved); and back up for all items being billed. The certification of Work will mean compliance by DESIGN/BUILD FIRM with the approved Project Schedule; that as-built drawings of improvements are current for the prior period; and Applicable Laws are being met and complied with. Each requisition for payment shall be submitted to the Project Manager for approval. Payment for Work performed will be made in accordance with the Florida Prompt Payment Act, Sections 255.0705 - 255.078, Florida Statutes, but not more frequently than once a month. The Contract Administrator shall verify completion of the various phases, as noted, and authorize payment accordingly. Should the Project fall behind schedule, as indicated in the Project Schedule, DESIGN/BUILD FIRM shall include a written plan demonstrating how the Final Completion date shall be maintained.

Material purchases can be invoiced to the CITY, upon receipt of invoice and documentation of order placement must be accompanied by a bill of sale from the manufacturer or supplier. The CITY will endeavor to pay material invoices earlier, albeit not later than thirty (30) days of receipt of a valid invoice. Any invoices that are not considered valid will be returned immediately for correction or additional documentation. No more than eight percent (8%) contractor's mark-up will be allowed for materials.

- 9.4.2 CITY agrees that it will pay DESIGN/BUILD FIRM in accordance with the Florida Prompt Payment Act, within thirty (30) calendar days of receipt of DESIGN/BUILD FIRM's proper requisition for payment, as provided above.

9.4.2.1 CITY will review DESIGN/BUILD FIRM's invoices and, if inaccuracies or errors are discovered in said invoice, CITY will inform DESIGN/BUILD FIRM within ten (10) working days by fax and/or by email of such inaccuracies or errors and request that revised copies of all such documents be re-submitted by DESIGN/BUILD FIRM to CITY.

9.4.2.2 Payments are scheduled to be made by CITY to DESIGN/BUILD FIRM using a credit card /CITY Procurement Card (P-Card).

9.4.2.3 Payment may be made to CONSULTANT at:

**Company name, address, email,
phone**

- 9.4.3 The DESIGN/BUILD FIRM shall use the sums advanced to it solely for the performance of the Work and the construction, furnishing and equipping of the Work in accordance with the Contract Documents and payment of bills incurred by the DESIGN/BUILD FIRM in performance of the Work.
- 9.4.4 DESIGN/BUILD FIRM shall remain liable for subcontractors' work and for any unpaid laborers, material suppliers of subcontractors in the event it is after discovered that said work is deficient or that any subcontractors, laborers, or material suppliers did not receive payments due to them on the Project.
- 9.4.5 Undisputed amounts remaining unpaid thirty (30) calendar days after CITY's request of DESIGN/BUILD FIRM's proper requisition for payment for conforming Work shall bear interest at the rate set forth in Section 218.74(4), Florida Statutes. This Section shall not apply if the CITY has a right to withhold any portion of the payment under this Agreement.
- 9.4.6 Pursuant to Florida Statutes, Section 255.078, five percent (5%) of all monies earned by DESIGN/BUILD FIRM shall be retained by the CITY until the Project has obtained Final Completion and been accepted by the CITY. The CITY may incrementally reduce the rate of retainage pursuant to a schedule provided for in the agreement, or from releasing at any point or a portion of any retainage withheld by the CITY which is attributable to the labor, services, or materials supplied by the Consultant or by one or more subconsultant or suppliers, if applicable and determined to be in the City's best interest. If the City makes any payment of retainage to Consultant which is attributable to the labor, services, or materials supplied by one or more subconsultant or suppliers, the Consultant must timely remit payment of such retainage to those subconsultants and suppliers.
- 9.5 If, after the Project has been substantially completed, full completion thereof is delayed through no fault of DESIGN/BUILD FIRM, or by issuance of Change Orders affecting final completion, and the Project Manager so certifies. CITY shall, upon certification of the Project Manager, and without terminating the Agreement, make payment of the balance due for that portion of the Project fully completed and accepted. Such payment shall be made as required by law under the terms and conditions governing final payment, except that it shall not constitute a waiver of claims.
- 9.6 Upon receipt of written notice from DESIGN/BUILD FIRM that the Project is ready for final inspection and acceptance, the Project Manager shall, within seven (7) calendar days, make an inspection thereof. If the Project Manager finds the Project acceptable under the

Contract Documents and the Project fully performed, a Final Certificate of Payment shall be issued by the Contract Administrator over his/her own signature, stating that the Work required by this Agreement has been completed and is accepted under the terms and conditions thereof.

- 9.7 Before issuance of the Final Certificate for Payment, DESIGN/BUILD FIRM shall deliver to the Project Manager a complete release of all liens arising out of this Agreement, or receipts in full in lieu thereof, and an affidavit certifying that all suppliers, consultant, subcontractors, and subconsultants have been paid in full, and that all other indebtedness connected with the Project has been paid, and a consent of the surety to final payment. All as-builts, warranties, guarantees, operational manuals, and instructions in operation must be delivered to CITY at this time. The warranties provided after the initial warranty period of year one will be covered under the warranty bond attached as an Exhibit to this Agreement. DESIGN/BUILD FIRM shall submit a completed as-built drawings package signed and sealed by a land surveyor registered in the State of Florida and as approved by the CITY's Public Works Department, and proof that all permits have been closed, which shall be delivered prior to requesting final payment.
- 9.8 CITY may withhold final payment or any progress payment to such extent as may be necessary on account of:
- A. Defective Work not remedied;
 - B. Claims filed or written notices of nonpayment indicating probable filing of claims as may be prescribed by law by other parties against DESIGN/BUILD FIRM;
 - C. Failure of DESIGN/BUILD FIRM to make payments properly to Consultant, subcontractors or subconsultants, or for material or labor;
 - D. Damage to another subcontractor, subconsultant, supplier, material, person (as provided for in Florida Statute Chapter 713), party or person not remedied which are attributable to DESIGN/BUILD FIRM, its agents, servants, employees, contractor, consultant, subconsultants, subcontractors, sub-subcontractors, sub-subconsultants, material person and suppliers;
 - E. Liquidated damages pursuant to Article 7 herein;
 - F. As-built drawings not being in a current and acceptable state.
- 9.9 When the above grounds in 9.4.7 are removed or resolved, or DESIGN/BUILD FIRM provides a surety bond or a consent of surety satisfactory to CITY which will protect CITY in the amount withheld, payment may be made in whole or in part, as applicable.
- 9.10 If the Project Manager, in his/her reasonable judgment, determines that the portion of the Not To Exceed Price then remaining unpaid will not be sufficient to complete the Work in accordance with the Contract Documents, no additional payments will be due to the DESIGN/BUILD FIRM hereunder unless and until the DESIGN/BUILD FIRM, at its sole cost, performs a sufficient portion of the Work so that such portion of the Not To Exceed Price then remaining unpaid is determined by the Project Manager to be sufficient to so complete the Work.
- 9.11 The making and acceptance of the final payment shall constitute a waiver of all claims by CITY,

other than those arising from faulty or defective Work, failure of the Project to comply with requirements of the Contract Documents, or terms of any warranties required by the Contract Documents. It shall also constitute a waiver of all claims by DESIGN/BUILD FIRM, except those previously made in writing and identified by DESIGN/BUILD FIRM as unsettled at the time of the final application for payment.

- 9.12 The DESIGN/BUILD FIRM warrants to the CITY that all materials and equipment furnished under this Agreement will be new unless otherwise specified, and that all Work will be of good quality and in conformance with the Contract Documents. Any warranties that are extended to the CITY beyond the standard warranty are to be in writing with the servicing firm information attached as an Exhibit. All Work not conforming to these requirements, including substitutions not properly approved and authorized by Contract Administrator, may be considered defective. If required by the CITY, the DESIGN/BUILD FIRM shall furnish satisfactory evidence as to the origin, nature and quality of materials and equipment used for the Project. DESIGN/BUILD FIRM shall properly store and protect all construction materials. Materials which become defective through improper storage shall be replaced with new materials at no additional costs. The DESIGN/BUILD FIRM's warranty excludes damage or defect caused by abuse, modifications not executed by the DESIGN/BUILD FIRM, improper or insufficient maintenance, improper operation, or normal wear and tear under normal usage.

ARTICLE 10 - ADDITIONAL SERVICES AND CHANGES IN SCOPE OF WORK

- 10.1 Without invalidating the Agreement and without notice to any surety, CITY reserves and shall have the right to make such changes from time to time in the character and quantity of the Work as may be considered necessary or desirable to complete fully and acceptably the Project in a satisfactory manner. The CITY may order additions, deletions or revisions in the Work using agreed upon rates to be included in the Contract Documents and/or Schedule of Values. Upon receipt of a Change Order, the DESIGN/BUILD FIRM shall proceed with the Work involved. All Work shall be executed under the applicable conditions of the Contract Documents. If any Change Order causes an increase or decrease in the Contract Price or an extension or shortening of the Contract Time, an equitable adjustment will be made on the basis of a claim made by either party.
- 10.2 The Project Manager may authorize minor changes in the Work not involving an adjustment in the Contract Price or the Contract Time, which are consistent with the overall intent of the Contract Documents. Such changes must be in writing and signed by the CITY and DESIGN/BUILD FIRM.

ARTICLE 11 - DESIGN/BUILD FIRM'S RESPONSIBILITIES

- 11.1 The Parties acknowledge and agree that the DESIGN/BUILD FIRM will be responsible for the design, construction and construction management of the Project according to the DCP.
- 11.2 The DESIGN/BUILD FIRM will be responsible for security, with full cooperation of the CITY all permits for the Project, including without limitation, South Florida Water Management District, Broward County, Army Corps of Engineers and Florida Department of Environmental Protection. Except as provided in the precedingsentences, the DESIGN/BUILD FIRM shall be fully responsible for any and all other permits and approvals from all governmental authorities having jurisdiction over the Project. All permits and licenses require by federal, state or local laws, rules, and regulations necessary for the prosecution of the Project by DESIGN/BUILD FIRM pursuant to this Agreement shall be secured by the DESIGN/BUILD FIRM and paid for

by the CITY. It is the DESIGN/BUILD FIRM's responsibility to have and maintain appropriate certificate(s) of competency, valid for the Work to be performed, and for all persons working on the Project for whom a certificate of competency is required.

- 11.3 DESIGN/BUILD FIRM shall be fully responsible for the actions of all its agents, servants, employees, including, but not limited to, the contractor, consultant, subcontractors, sub-consultants, sub-subcontractors, materials persons (pursuant to Chapter 713, Florida Statutes), and any and all other persons working for it in conjunction with the design and construction of the Project.
- 11.4 DESIGN/BUILD FIRM shall be fully responsible for all acts or omissions of its contractor, consultant, subcontractors, sub-consultants, sub-subcontractors, sub-sub-consultants, materials persons, and any and all other persons working for DESIGN/BUILD FIRM in conjunction with the design and construction of the Project; any and all persons working for contractor, consultant, subcontractors or sub-consultant; and any and all persons for whose acts any of the aforesaid may be liable, to the same extent DESIGN/BUILD FIRM is responsible for the acts and omissions of persons directly employed by DESIGN/BUILD FIRM. Nothing in this Agreement shall create any contractual relationship between CITY and consultant, or CITY and any subcontractor, sub-consultant, sub-subcontractor, sub-sub-consultant, or any other person working either for DESIGN/BUILD FIRM or for any of the afore-stated parties in conjunction with the design and construction of the Project, including, without limitation, any obligation on the part of the CITY to pay or to see the payment of any monies due to any of the afore-stated parties pursuant to this Section.
- 11.5 DESIGN/BUILD FIRM agrees to bind its consultant, subcontractors, and sub-consultants to the applicable terms and conditions of this Agreement for the benefit of the CITY.
- 11.6 Unless otherwise provided herein, DESIGN/BUILD FIRM shall provide and pay for all architecture, engineering, landscape architecture, land surveying services, materials, construction and other labor, water, tools, equipment, light, power, transportation, and other facilities and services necessary for the proper execution and completion of the design and construction of the Project, whether temporary or permanent, and whether or not incorporated or to be incorporated in the Project.
- 11.7 DESIGN/BUILD FIRM shall at all times enforce strict discipline and good order among its employees, consultants, subcontractors and sub-consultants at the Project site, and shall not employ on the Project any unfit person or anyone not skilled in the work and/or services assigned to him or her.
- 11.8 DESIGN/BUILD FIRM shall keep itself fully informed of, and shall take into account and comply with any and all Applicable Laws affecting those engaged or employed in the Project; or the materials used or employed in the design and construction of the Project; or in any way affecting the conduct of the Project, including, without limitation, all such orders and decrees of bodies or tribunals having any jurisdiction or authority over the same and of all provisions required by law to be made a part of this Agreement, all of which provisions are hereby incorporated by reference and made a part hereof. If any specification or contract for this Project is in violation of any such Applicable Laws, DESIGN/BUILD FIRM shall forthwith report the same to the Project Manager in writing. DESIGN/BUILD FIRM shall cause all its employees, agents, consultant, subcontractors, subconsultants, sub-subconsultants and sub-subcontractors

to observe and comply with all Applicable Laws.

- 11.9 DESIGN/BUILD FIRM shall pay all applicable sales, consumer, use and other taxes required by law. DESIGN/BUILD FIRM is responsible for reviewing the pertinent state statutes involving state taxes and complying with all requirements.
- 11.10 If DESIGN/BUILD FIRM has knowledge that the Contract Documents do not comply with Applicable Laws, in any respect, the DESIGN/BUILD FIRM shall promptly notify the Project Manager, in writing, and any necessary changes shall be adjusted by appropriate revisions. If the DESIGN/BUILD FIRM performs any Work not in accordance with Applicable Laws, and without such notice to the Project Manager, the DESIGN/BUILD FIRM shall assume full responsibility therefore and shall bear all costs attributable thereto. DESIGN/BUILD FIRM warrants to CITY that it has thoroughly reviewed and studied the DCP, and has determined that it is in conformance with Applicable Laws, and is complete and sufficiently coordinated to perform the Work for the Not To Exceed Price and the Contract Time. DESIGN/BUILD FIRM warrants to CITY that the DCP is consistent, practical, feasible and constructible. DESIGN/BUILD FIRM further warrants to CITY that the Work described in the DCP is constructible for the Not To Exceed Price and the Contract Time.

THE CITY DISCLAIMS ANY WARRANTY THAT THE DCP FOR THE PROJECT IS ACCURATE, PRACTICAL, CONSISTENT, AND/OR CONSTRUCTIBLE.

- 11.11 DESIGN/BUILD FIRM accepts the Project site in its observable and/or documented condition existing at the time of this Agreement, or conditions ordinarily encountered and generally recognized as inherent to the character of the Work to be provided for in this Project. By signing this Agreement, the DESIGN/BUILD FIRM represents to the CITY that it has: (a) visited the Project site to become familiar with the conditions under which the Work is to be performed; (b) become familiar with all information provided (without warranty) by the CITY pertaining to the Project site; and (c) correlated its observations with the information furnished by the CITY (without warranty), and the Contract Documents. The DESIGN/BUILD FIRM hereby waives additional time or compensation for additional work made necessary by observable and/or documented conditions existing at the Project site, or conditions ordinarily encountered and generally recognized as inherent to the character of the Work to be provided for in this Project.
- 11.12 The DESIGN/BUILD FIRM agrees specifically that no Change Orders shall be required by the DESIGN/BUILD FIRM or considered by the CITY for reasons involving conflicts in the Contract Documents; questions of clarity with regard to the Contract Documents; and incompatibility or conflicts between the Contract Documents and the existing Project site conditions excluding, without limitation, utilities and unforeseen underground conditions at the discretion of the CITY and will not be unreasonably withheld. The DESIGN/BUILD FIRM acknowledges that it has ascertained all correct locations for points of connection for all utilities required for this Project.
- 11.13 The DESIGN/BUILD FIRM shall comply with all conditions of any permits issued by government authorities.
- 11.14 All material and equipment shall be of good quality and new, except as otherwise provided in the Contract Documents. Suppliers shall be selected and paid by the DESIGN/BUILD FIRM;

the CITY reserves the right to approve all suppliers and materials.

- 11.15 The DESIGN/BUILD FIRM shall pay all license fees and royalties and assume all costs incident to the use in the performance of the Work or the incorporation in the Work, or any invention, design, process, product or device which is the subject of patent rights or copyrights held by others. The DESIGN/BUILD FIRM hereby expressly binds itself to indemnify and save harmless the CITY from all such claims and fees and from any and all suits and actions of every name and description that may be brought against CITY on account of any such claims, fees, royalties, or costs for any such invention or patent, and from any and all suits or actions that may be brought against said CITY for the infringement of any and all patents or patent rights claimed by any person, firm, corporation or other entity.
- 11.16 Except in connection with the safety or protection of persons, or the Work, or property at the site or adjacent thereto, and except as otherwise indicated in the Supplementary Conditions, all work at the site shall be performed during regular working hours between 7:00 am to 7:00 pm, Monday through Friday. The DESIGN/BUILD FIRM will not permit overtime work or the performance of work on Saturday, Sunday or any legal holiday (designated by the CITY of Fort Lauderdale) without the Project Manager's written consent at least seventy-two (72) hours in advance of starting such work. If the Project Manager permits overtime work, the DESIGN/BUILD FIRM shall pay for the additional charges to the CITY with respect to such overtime work. Such additional charges shall be a subsidiary obligation of the DESIGN/BUILD FIRM and no extra payment shall be made to the DESIGN/BUILD FIRM for overtime work. The cost to the DESIGN/BUILD FIRM to reimburse the CITY for overtime inspections is established at direct-labor and overtime costs for each person or inspector required. Incidental overtime costs for engineering, testing and other related services will also be charged to the DESIGN-BUILD FIRM at the actual rate accrued.

CITY Inspector Hours: 8:00 am to 4:30 pm

Overtime: 5:01 pm to 7:59 am

Inspection Overtime Cost: \$100/hr.

- 11.17 DESIGN/BUILD FIRM requests to work during other than regular hours that conform to the standard hours listed in the CITY's Noise Ordinance Section 17-8 (1), must be submitted to the DCP and CITY Project Manager with six (6) business days in advance of scheduled work. Request shall include the following information:

- Cover page with DESIGN/BUILD FIRM name, project name, and location
- Description of work to be performed outside of normal work hours
- Site plan and location map
- Legal description
- Justification for work and why extended work hours are being requested
- Commencement date and duration of work
- List of DESIGN/BUILD FIRM contacts, including those on site
- Details on type of equipment to be used during extended work hours

- Details on noise levels that may be produced by range of decibels, including current ambient levels at site and levels predicted from proposed construction impacts
- Details on vibratory control measures to be implemented
- Details on how neighbors in vicinity of work area will be notified
- Details on how complaints will be resolved and/or mitigated
- Maintenance of Traffic plans approved by CITY's Transportation and Mobility Department (TAM) and any other agencies (if applicable).

11.17.1 If no lane closure or traffic impacts are necessary, the DESIGN/BUILD FIRM request must be submitted seven (7) business days in advance of scheduled work. If the Work requires lane closures, request should be submitted at least ten (10) business days in advance, along with MOT plans approved by CITY's TAM, and any other agencies if necessary, to allow time for CITY Manager consideration and approval, CITY MOT permit issuance, and notification to the public.

11.17.2 The DESIGN/BUILD FIRM will not be permitted overtime work or the performance of work on Saturday, Sunday or any legal holiday (designated by the CITY of Fort Lauderdale) without the CITY Manager's written consent at least seventy-two (72) hours in advance of the period proposed for such overtime work. Hours of work shall conform to the requirements of the CITY's Noise Ordinance.

11.17.3 If the DESIGN-BUILD FIRM requests to work outside regular hours that require a special exemption from the provisions of Section 17-7.4, it shall follow the CITY's Department of Sustainable Development's process for "Requesting Exemption from the Noise Ordinance," located at:

<https://www.fortlauderdale.gov/government/departments-i-z/sustainable-development/building-services/building-permit-general-info>

11.17.4 The DESIGN/BUILD FIRM will not permit overtime work or the performance of work on Saturday, Sunday or any legal holiday (designated by the City of Fort Lauderdale) without the approval from the CITY Manager or CITY Commission approval at least seventy-two (72) hours in advance of starting such work.

- 11.18 In the event of an emergency affecting the safety or protection of persons or the Work or property at the site or adjacent thereto, DESIGN/BUILD FIRM, without special instruction or authorization from the CITY is obligated to act to prevent threatened damage, injury or loss. DESIGN/BUILD FIRM shall give the Project Manager prompt written notice of any significant changes in the Work or deviations from the Contract Documents caused thereby.
- 11.19 Upon issuance of a hurricane watch by the National Weather Service, DESIGN/BUILD FIRM shall submit to the CITY a plan to secure the work area in the event a hurricane warning is issued. The plan shall detail how the DESIGN/BUILD FIRM will secure the premises, equipment and materials in a manner as to prevent damage to the Work and prevent materials and equipment from becoming a hazard to persons and property on and around the premises. The plan shall include a time schedule required to accomplish the

hurricane preparations and a list of emergency contacts that will be available and in the CITY before, during and immediately after the storm.

Upon issuance of a hurricane warning by the National Weather Service, if the DESIGN/BUILD FIRM has not already done so, the DESIGN/BUILD FIRM shall implement its hurricane preparedness plan. Cost of development and implementation of the hurricane preparedness plan shall be considered as incidental to construction. Cost of any clean up and rework required after the storm will be considered normal construction risk within Florida and shall not entitle

the DESIGN/BUILD FIRM to any additional compensation. DESIGN/BUILD FIRM shall be entitled to request an extension of time for completion of the Work, in accordance with the provision of Article 8 of this Agreement, equal to the time it is shut down for implementation of the preparedness plan, the duration of the storm and a reasonable period to restore the Premises.

- 11.20 Force Majeure: No Party shall hold the other responsible for damages or for delays in performance caused by force majeure, acts of God, or other acts or circumstances beyond the control of the other party or that could not have been reasonably foreseen and prevented. For these purposes, such acts or circumstances shall include, but not be limited to, weather conditions affecting performance, floods, epidemics, war, riots, strikes, lockouts, or other industrial disturbances, or protest demonstrations. Should such acts or circumstances occur, the parties shall use their best efforts to overcome the difficulties arising therefrom and to resume the Work as soon as reasonably possible with the normal pursuit of the Work.

Inclement weather, continuous rain for less than three (3) days or the acts or omissions of subcontractors, third-party contractors, materialmen, suppliers, or their subcontractors, shall not be considered acts of force majeure.

No Party shall be liable for its failure to carry out its respective obligations under the Agreement during a period when such Party is rendered unable by force majeure to carry out its obligation, but the obligation of the Party or Parties relying on such force majeure shall be suspended only during the continuance of the inability and for no longer period than the unexpected or uncontrollable event.

The DESIGN/BUILD FIRM further agrees and stipulates, that its right to excuse its failure to perform by reason of force majeure shall be conditioned upon giving written notice of its assertion that a force majeure delay has commenced within 96 hours after such an occurrence. The DESIGN/BUILD FIRM shall use its reasonable efforts to minimize such delays. The DESIGN/BUILD FIRM shall promptly provide an estimate of the anticipated additional time required to complete the Project.

ARTICLE 12 - CITY'S RESPONSIBILITIES

- 12.1 CITY shall assist DESIGN/BUILD FIRM by placing at its disposal any available information pertinent to the Project including previous reports, laboratory tests and inspections of samples, materials and equipment, property, boundary, easement, rights-of-way, topographic and utility surveys; property descriptions; and known zoning, deed and other land use restrictions.
- 12.2 CITY shall arrange for access to and make all provisions for DESIGN/BUILD FIRM to enter upon public property as required for DESIGN/BUILD FIRM to perform its services.

- 12.3 CITY shall render decisions under this Agreement in a timely manner.

ARTICLE 13 - SUPERINTENDENCE AND SUPERVISION

- 13.1 The orders of the CITY are to be given through the Project Manager, whose instructions are to be strictly and promptly followed in every case, provided that they are in accordance with this Agreement and the other Contract Documents. Construction Manager shall keep on the Project during its progress, a full-time, competent, English speaking supervisor, who shall be the Construction Manager Representative and who shall serve as the superintendent, and any necessary assistants, all satisfactory to the Project Manager.
- 13.2 Construction Manager or Construction Manager Representative shall prepare, on a daily basis, and keep on the Project site, a bound log setting forth at a minimum, for each day: the weather conditions and how any weather conditions affected progress of the Work; time of commencement of Work for the day; the Work performed; materials, labor, personnel, equipment and subcontractors used for the Work; any idle equipment and reasons for idleness; visitors to the Project site; any special or unusual conditions or occurrences encountered; any materials delivered to the Project site; and the time of termination of Work for the day. The daily bound log shall be available for inspection by the CITY, or its authorized designee, at all times during the Project, without previous notice.
- 13.3 If DESIGN/BUILD FIRM, in the course of the Project, finds any discrepancy between the Contract Documents and the physical conditions of the site, or any errors or omissions in the Contract Documents including, but not limited to, the Plans and Specifications, it shall be DESIGN/BUILD FIRM's sole obligation and duty to immediately inform the Project Manager, in writing, and the Project Manager will promptly verify same. Any Work done prior to or after such discovery will be done at DESIGN/BUILD FIRM's sole risk. **NOTWITHSTANDING THE PRECEDING, OR ANY OTHER TERM OR CONDITION OF THIS AGREEMENT, DESIGN/BUILD FIRM HEREBY ACKNOWLEDGES AND AGREES THAT THIS IS A DESIGN/BUILD PROJECT AND, ACCORDINGLY, ANY ERRORS OR OMISSIONS SHALL BE CORRECTED AT THE SOLE COST AND EXPENSE OF DESIGN/BUILD FIRM AND WITHOUT A CLAIM FOR ADJUSTMENT IN THE CONTRACT TIME OR CONTRACT PRICE.**
- 13.4 DESIGN/BUILD FIRM shall coordinate, supervise and direct the Project competently and efficiently, devoting such attention thereto and applying such skills and expertise as may be necessary to perform and complete the Project in accordance with the Contract Documents. DESIGN/BUILD FIRM shall be solely responsible for the design, preparation of Construction Documents, means, methods, techniques, safety, sequences and procedures of construction. DESIGN/BUILD FIRM shall give efficient supervision to the Work, using DESIGN/BUILD FIRM's best skill, attention and judgment.

ARTICLE 14 - RESOLUTION OF DISPUTES

- 14.1 Questions, claims, difficulties and disputes of whatever nature which may arise relative to the technical interpretation of the Contract Documents and fulfillment of this Agreement as to the character, quality, amount and value of any work done and materials furnished, or proposed to be done or furnished under or, by reason of, the Contract Documents which cannot be resolved by mutual agreement of CITY Project Manager and DESIGN/BUILD FIRM Project Manager shall be submitted to the City Manager or his designee and DESIGN/BUILD FIRM's representative for resolution. When either Party has determined that a disputed question, claim,

difficulty or dispute is at an impasse, that Party shall notify the other party in writing and submit the question, claim, difficulty or dispute to the next level of the Parties' respective management levels for resolution. Each Party may determine in such Party's reasonable discretion as to who the "next level of management" is for purposes of resolving disputes.

- 14.2 All non-technical administrative disputes (such as billing and payment) shall be determined by the Project Manager.
- 14.3 During the pendency of any dispute and after a determination thereof, DESIGN/BUILD FIRM, and CITY shall act in good faith to mitigate any potential damages including using construction schedule changes and alternate means of construction. During the pendency of any dispute arising under this Agreement, other than termination herein, DESIGN/BUILD FIRM shall proceed diligently with performance of this Agreement and CITY shall continue to make payments for undisputed amounts in accordance with the Contract Documents.
- 14.4 In the event a resolution of a dispute under this section cannot be resolved, the issue shall be submitted by the DESIGN/BUILD FIRM to the City Manager or designee, in writing within ten (10) days of the impasse. The notice must state the basis of the dispute and the DESIGN/BUILD FIRM's proposed resolution. The notice given by the DESIGN/BUILD FIRM must include a written notarized certification that any NTE adjustment claimed is the entire adjustment to which the DESIGN/BUILD FIRM has reason to believe it is entitled to as a result of the question, claim, difficulty or dispute. Resolution of such dispute shall be made by the City Manager or designee. The City Manager's decision shall be final and binding on the Parties subject to mediation and judicial review.
- 14.5 Prior to any litigation being commenced, for any disputes which remain unresolved, within sixty (60) days after Final Completion of the Work, the Parties shall participate in mediation to address all unresolved disputes to a mediator mutually agreed upon by the Parties. Should any objection not be resolved in mediation, the Parties retain all their legal rights and remedies provided under the laws of Florida. Failure by a Party to comply in strict accordance with the requirements of this Article, then said Party specifically waives all of its rights provided hereunder, including its rights and remedies under the laws of Florida.

ARTICLE 15 - CITY'S RIGHT TO TERMINATE AGREEMENT

- 15.1 If DESIGN/BUILD FIRM fails to begin the design and construction of the Project within the time specified, or fails to perform the Project with sufficient workers and equipment or with sufficient materials to insure the prompt completion of the Project, in accordance with the Contract Documents and schedules, or shall perform the Work unsuitably, or cause it to be rejected as defective and unsuitable; or shall discontinue the prosecution of the Project, except for excused delays in accordance with this Agreement; or if DESIGN/BUILD FIRM shall become insolvent or be declared bankrupt, or commit any act of bankruptcy or insolvency, or shall make an assignment for the benefit of creditors; or shall not carry on the Project in accordance with the Contract Documents, then the CITY shall give notice, in writing, to DESIGN/BUILD FIRM and its surety of such delay, neglect or default, specifying the same. If DESIGN/BUILD FIRM within a period of ten (10) calendar days after such notice, shall not proceed in accordance therewith, then CITY may, upon written notice from the Project Manager of the fact of such delay, neglect or default and DESIGN/BUILD FIRM's failure to comply with such notice, terminate the services of DESIGN/BUILD FIRM, exclude DESIGN/BUILD FIRM from the Project site, and take the prosecution of

the Project out of the hands of DESIGN/BUILD FIRM, as appropriate, or use any or all materials and equipment on the Project site as may be suitable and acceptable, in the CITY's reasonable discretion. In such case, DESIGN/BUILD FIRM shall not be entitled to receive any further payment until the Project is finished. In addition, CITY may enter into an Agreement for the completion of the Project according to the terms and provisions of the Contract Documents, or use such other methods as in its opinion shall be required for the completion of the Project in an acceptable manner. All damages, costs and charges incurred by CITY shall be deducted from any monies due or which may become due to said DESIGN/BUILD FIRM. Actions will be instituted to recover on the posted bonds. In case the damages and expense so incurred by CITY shall be less than the sum which would have been payable under this Agreement, if it had been completed by said DESIGN/BUILD FIRM, then DESIGN/BUILD FIRM shall be entitled to receive the difference. If such damages and costs exceed the unpaid balance, then DESIGN/BUILD FIRM shall be liable and shall pay to CITY the amount of said excess.

- 15.2 If, after Notice of Termination of DESIGN/BUILD FIRM's right to proceed, it is determined for any reason that DESIGN/BUILD FIRM was not in default, the rights and obligations of CITY and DESIGN/BUILD FIRM shall be the same as if the notice of termination had been issued pursuant to the Termination for Convenience clause, as set forth in Section 15.3 below.
- 15.3 Notwithstanding any other provision in this Agreement, the performance of work under this Agreement may be terminated in writing by CITY, for convenience and without cause, upon ten (10) business days from the date of DESIGN/BUILD FIRM's receipt of the written notice to DESIGN/BUILD FIRM of intent to terminate and the date on which such termination becomes effective. In such case, DESIGN/BUILD FIRM shall be paid for all Work and reimbursables executed, and expenses incurred, such as materials stored, cost of severance of leases/contracts directly associated with the Project, and demobilization prior to termination. PAYMENT SHALL INCLUDE REASONABLE PROFIT FOR SERVICES ACTUALLY PERFORMED IN FULL PRIOR TO TERMINATION DATE, BUT SHALL EXCLUDE ALL LOSS PROFITS, INDIRECT CONSEQUENTIAL, SPECIAL OR OTHER DAMAGES.
- 15.4 Upon receipt of Notice of Termination pursuant to Sections 15.1 and 15.2 above, DESIGN/BUILD FIRM shall, at its sole cost and expense (other than demobilization as a result of the Notice of Termination pursuant to Section 15.3 which shall be paid for by the CITY) and as a condition precedent to any further payment obligation by the CITY, promptly discontinue all affected work, unless the Notice of Termination directs otherwise, and deliver to CITY within seven (7) calendar days of termination, all data, drawings, specifications, reports, estimates, summaries and such other information as may have been required by the Contract Documents, whether completed or in process. Compensation shall be withheld until all documents are produced to CITY pursuant to this Article.

ARTICLE 16 - DESIGN/BUILD FIRM'S RIGHT TO STOP WORK OR TERMINATE CONTRACT

- 16.1 If the Project should be stopped under any order of any court or other public authority for a period of more than ninety (90) calendar days, through no act or fault of DESIGN/BUILD FIRM or of anyone employed by DESIGN/BUILD FIRM, or if the Project Manager should fail to review and approve or state in writing reasons for non- approval of any requisition for

payment within twenty (20) business days after it is presented; or if CITY fails to pay DESIGN/BUILD FIRM within thirty (30) calendar days after submittal of a proper requisition for payment, as approved by the Project Manager, then DESIGN/BUILD FIRM may give written notice to CITY, of such delay, neglect or default, specifying same. If CITY, within a period of ten (10) business days after suchwritten notice, shall not remedy the delay, neglect, or default upon which notice is based, then DESIGN/BUILD FIRM may stop work until payment is made, or terminate this Agreement and recover from CITY payment for all Work executed and reasonable expenses sustained, but excluding any claim for payments for loss profits, indirect, special, consequential or other damages.

ARTICLE 17 - NOTICES

17.1 Whenever either Party desires to give notice to the other, such notice must be in writing with proof of delivery or receipt. The notice shall be address to the Party for whom it is intended at the place last specified; and the place for giving of notice shall remain until itshall have been changed by written notice in compliance with the provisions of this paragraph. For the present, the Parties designate the following as the respective places for giving notice:

<p>FOR THE CITY: CITY Manager CITY of Fort Lauderdale 100 North Andrews Avenue Fort Lauderdale, Florida 33301</p> <p>with copies to: Project Manager and City Attorney City of Fort Lauderdale 100 North Andrews Avenue Fort Lauderdale, Florida 33301</p>	<p>FOR THE DESIGN/BUILD FIRM: Vendor name, contact and address</p>
---	---

ARTICLE 18 – BONDS AND INSURANCE

18.1 DESIGN/BUILD FIRM shall furnish, or cause to be furnished, on or before seven (7) days after execution of this Agreement, the following:

Performance Bond and Payment Bond (Surety)

18.2 THE DESIGN/BUILD FIRM shall execute and record in the Public Records of Broward County, Florida, a payment and performance bond in an amount at least equal to the Contract Price guaranteeing to CITY the completion and performance of the Project covered in this Agreement as well as full payment of all suppliers, material persons, laborers, or sub-contractors employment pursuant to the Project. The Payment and Performance Bond shall be with a surety insurer authorized to do business in the state of Florida as surety (“Bond”), in accordance with Sec. 255.05, Fla. Stat., as may be amended or revised, as security for the faithful performance and payment of all of the Contractor’s obligations under the Contract Documents. The performance and payment bond shall remain in full force and effect during the Project and 60 days beyond the contract term for close out.

18.3

Insurance Requirements

Commercial General Liability

Coverage must be afforded under a Commercial General Liability policy with limits not less than:

- \$5,000,000 each occurrence and \$5,000,000 aggregate for Bodily Injury, Property Damage, and Personal and Advertising Injury
- \$5,000,000 each occurrence and \$5,000,000 aggregate for Products and Completed Operations

Policy must include coverage for contractual liability and independent contractors.

The City, a Florida municipality, its officials, employees, and volunteers are to be covered as an additional insured with a CG 20 26 04 13 Additional Insured – Designated Person or Organization Endorsement or similar endorsement providing equal or broader Additional Insured Coverage with respect to liability arising out of activities performed by or on behalf of Contractor. The coverage shall contain no special limitation on the scope of protection afforded to the City, its officials, employees, and volunteers.

Professional Liability

Coverage must be afforded for Wrongful Acts in an amount not less than \$5,000,000 each claim and \$5,000,000 aggregate.

Contractor must keep the professional liability insurance in force until the third anniversary of expiration or early termination of this Agreement or the third anniversary of acceptance of work by the City, whichever is longer, which obligation shall survive expiration or early termination of this Agreement.

Pollution and Remediation Legal Liability (Hazardous Materials)

For the purpose of this section, the term “hazardous materials” includes all materials and substances that are designated or defined as hazardous by Florida or federal law or by the rules or regulations of Florida or any federal agency. If work being performed involves hazardous materials, Contractor shall procure and maintain any or all of the following coverages (which will be specifically addressed upon review of exposure):

Contractors Pollution Liability Coverage

For sudden and gradual occurrences and in an amount not less than \$1,000,000 per claim arising out of this Agreement, including but not limited to, all hazardous materials identified under the Agreement.

Business Automobile Liability

Coverage must be afforded for all Owned, Hired, Scheduled, and Non-Owned vehicles for Bodily Injury and Property Damage in an amount not less than \$1,000,000 combined single limit each accident.

If Contractor does not own vehicles, Contractor shall maintain coverage for Hired and Non-

Owned Auto Liability, which may be satisfied by way of endorsement to the Commercial General Liability policy or separate Business Auto Liability policy.

Crane and Rigging Liability

Coverage must be afforded for any crane operations under the Commercial General or Business Automobile Liability policy as necessary, in line with the limits of the associated policy.

Workers' Compensation and Employer's Liability

Coverage must be afforded per Chapter 440, Florida Statutes. Any person or entity performing work for or on behalf of the City must provide Workers' Compensation insurance. Exceptions and exemptions will be allowed by the City's Risk Manager, if they are in accordance with Florida Statute.

Contractor waives, and Contractor shall ensure that Contractor's insurance carrier waives, all subrogation rights against the City, its officials, employees, and volunteers for all losses or damages. The City requires the policy to be endorsed with WC 00 03 13 Waiver of our Right to Recover from Others or equivalent.

Contractor must be in compliance with all applicable State and federal workers' compensation laws, including the U.S. Longshore and Harbor Workers' Compensation Act and the Jones Act, if applicable.

Insurance Certificate Requirements

- a. Contractor shall provide the City with valid Certificates of Insurance (binders are unacceptable) no later than ten (10) days prior to the start of work contemplated in this Agreement.
- b. Contractor shall provide to the City a Certificate of Insurance having a thirty (30) day notice of cancellation; ten (10) days' notice if cancellation is for nonpayment of premium.
- c. In the event that the insurer is unable to accommodate the cancellation notice requirement, it shall be the responsibility of Contractor to provide the proper notice. Such notification will be in writing by registered mail, return receipt requested, and addressed to the certificate holder.
- d. In the event the Agreement term or any surviving obligation of Contractor following expiration or early termination of the Agreement goes beyond the expiration date of the insurance policy, Contractor shall provide the City with an updated Certificate of Insurance no later than ten (10) days prior to the expiration of the insurance currently in effect. The City reserves the right to suspend the Agreement until this requirement is met.
- e. The Certificate of Insurance shall indicate whether coverage is provided under a claims-made or occurrence form. If any coverage is provided on a claims-made form, the Certificate of Insurance must show a retroactive date, which shall be the effective date of the initial contract or prior.

- f. The City shall be covered as an Additional Insured on all liability policies, with the exception of Workers' Compensation and Professional Liability.
- g. The City shall be granted a Waiver of Subrogation on Contractor's Workers' Compensation insurance policy.
- h. The title of the Agreement, Bid/Contract number, event dates, or other identifying reference must be listed on the Certificate of Insurance.

The Certificate Holder should read as follows:

City of Fort Lauderdale
100 N. Andrews Avenue
Fort Lauderdale, FL 33301

Contractor has the sole responsibility for all insurance premiums and shall be fully and solely responsible for any costs or expenses as a result of a coverage deductible, co-insurance penalty, or self-insured retention; including any loss not covered because of the application of such deductible, co-insurance penalty, self-insured retention, or coverage exclusion or limitation. Any costs for adding the City as an Additional Insured shall be at Contractor's expense.

If Contractor's primary insurance policy/policies do not meet the minimum requirements as set forth in this Agreement, Contractor may provide evidence of an Umbrella/Excess insurance policy to comply with this requirement.

Contractor's insurance coverage shall be primary insurance in respect to the City's interests, a Florida municipality, its officials, employees, and volunteers. Any insurance or self-insurance maintained by the City shall be non-contributory.

Any exclusion or provision in any insurance policy maintained by Contractor that excludes coverage required in this Agreement shall be deemed unacceptable and shall be considered breach of contract.

All required insurance policies must be maintained until the Agreement work has been accepted by the City, or until this Agreement is terminated, whichever is later. Any lapse in coverage may be considered breach of contract. In addition, Contractor must provide to the City confirmation of coverage renewal via an updated certificate of insurance should any policies expire prior to the expiration of this Agreement. The City reserves the right to review, at any time, coverage forms and limits of Contractor's insurance policies.

Contractor shall provide notice of any and all claims, accidents, and any other occurrences associated with this Agreement to Contractor's insurance company or companies and the City's Risk Management office as soon as practical.

It is Contractor's responsibility to ensure that any and all of Contractor's independent contractors and subcontractors comply with these insurance requirements. All coverages for independent contractors and subcontractors shall be subject to all of the applicable

requirements stated herein. Any and all deficiencies are the responsibility of Contractor. The City reserves the right to adjust insurance limits from time to time at its discretion with notice to Contractor.

NOTE: CITY PROJECT NUMBER, PROJECT NAME AND BID NUMBER MUST APPEAR ON EACH CERTIFICATE, AND THE CITY OF FORTLAUDERDALE MUST BE NAMED ON THE CERTIFICATE AS AN “ADDITIONAL INSURED” ON REQUIRED LIABILITY POLICIES.

The Certificate Holder must read as follows:

City of Fort Lauderdale
100 N. Andrews Avenue
Fort Lauderdale, FL
33301

- 18.4 The DESIGN/BUILD FIRM has the sole responsibility for all insurance premiums and shall be fully and solely responsible for any costs or expenses as a result of a coverage deductible, co-insurance penalty, or self-insured retention; including any loss not covered because of the operation of such deductible, co-insurance penalty, self-insured retention, or coverage exclusion or limitation. Any costs for adding the CITY as an Additional Insured shall be at the DESIGN/BUILD FIRM's expense.

If the DESIGN/BUILD FIRM primary insurance policy/policies do not meet the minimum requirements, as set forth in this Agreement, the DESIGN/BUILD FIRM may provide an Umbrella/Excess insurance policy to comply with this requirement.

The DESIGN/BUILD FIRM's insurance coverage shall be primary insurance as respects to the CITY, a Florida municipal corporation, its officials, employees, and volunteers. Any insurance or self-insurance maintained by the CITY, a Florida municipal corporation, its officials, employees, or volunteers shall be non-contributory.

Any exclusions or provisions in any insurance policy maintained by the DESIGN/BUILD FIRM that excludes coverage required in this Agreement shall be deemed unacceptable and shall be considered breach of contract.

All required insurance policies must be maintained until the contract work has been accepted by the CITY, or until this Agreement is terminated, whichever is later. Any lapse in coverage shall be considered breach of contract. In addition, DESIGN/BUILD FIRM must provide to the CITY confirmation of coverage renewal via an updated certificate should any policies expire prior to the expiration of this Agreement. The CITY reserves the right to review, at any time, coverage forms and limits of DESIGN/BUILD FIRM's insurance policies.

The DESIGN/BUILD FIRM shall provide notice of any and all claims, accidents, and any other occurrences associated with this Agreement to the DESIGN/BUILD FIRM's insurance company or companies and the CITY's Risk Management office, as soon as practical.

It is the DESIGN/BUILD FIRM's responsibility to ensure that any and all of the DESIGN/BUILD FIRM independent contractors and subcontractors comply with these

insurance requirements. All coverages for independent contractors and subcontractors shall be subject to all of the applicable requirements stated herein. Any and all deficiencies are the responsibility of the DESIGN/BUILD FIRM.

Certificates will indicate no modification or change in insurance shall be made without thirty (30) days in advance notice to the certificate holder. Compliance with the foregoing requirements shall not relieve the DESIGN/BUILD FIRM of its liability and obligation under this section or under any other Section of this Agreement.

- 18.5 The DESIGN/BUILD FIRM shall be responsible for assuring that the insurance certificates required in conjunction with this Section remain in force for the duration of the Project. If insurance certificates are scheduled to expire during the contractual period, the DESIGN/BUILD FIRM shall be responsible for submitted new or renewed insurance certificates to the CITY at a minimum of thirty (30) calendar days in advance of such expiration. In the event that expired certificates are not replaced with new or renewed certificates that cover the contractual period, the CITY shall:
- A. Suspend the Agreement until such time as the new or renewed certificates are received by the CITY;
 - B. The CITY may, at its sole discretion, terminate the Agreement for cause and seek damages from the DESIGN/BUILD FIRM in conjunction with the violation of the terms and conditions of the Agreement.

ARTICLE 19 - SUBSTANTIAL COMPLETION

- 19.1 When DESIGN/BUILD FIRM considers that the Project, or a designated portion thereof, which is acceptable to CITY, in the event CITY chooses to accept same pursuant to the sole authority and discretion, is substantially complete, DESIGN/BUILD FIRM shall so notify the Project Manager, in writing, and shall prepare for submission to the Project Manager a thorough list of items to be completed or corrected, together with a schedule for completion of all items. The failure to include any items on such list does not alter the responsibility of DESIGN/BUILD FIRM to complete all Work in accordance with the Contract Documents. The Project Manager, and such other persons as they may deem necessary, shall conduct a joint inspection to determine that the Project (or designated portion thereof) is substantially complete.
- 19.2 The Project Manager will then instruct DESIGN/BUILD FIRM to prepare and deliver to the Contract Administrator a Certificate of Substantial Completion which shall establish the date of Substantial Completion for the Project (or that portion of the Project). After review of the certificate by the Contract Administrator, CITY shall either accept or reject the certificate. Acceptance of Substantial Completion by CITY shall be based upon compliance with the Contract Documents and Applicable Laws. DESIGN/BUILD FIRM shall have thirty (30) days to complete the items listed therein. Warranties required by the Contract Documents and submitted in appropriate form to the Project Manager along with the request for Substantial Completion shall commence on the date of Substantial Completion of the Project (or for that portion of the Project). The Certificate of Substantial Completion shall be submitted to CITY through the Project Manager and DESIGN/BUILD FIRM for its written acceptance of the responsibilities assigned to it in such Certificate.

ARTICLE 20 - FINAL COMPLETION

- 20.1 When the DESIGN/BUILD FIRM considers that the Project, or a designated portion thereof, which is acceptable to CITY, in the event CITY chooses to accept same pursuant to the sole authority and discretion, is finally complete, DESIGN/BUILD FIRM shall so notify the Project Manager, in writing, that the work is complete, and that the DESIGN/BUILD FIRM has satisfied all prerequisites to Final Completion. The DESIGN/BUILD FIRM and the Project Manager and such other persons as they may deem necessary, shall conduct a final inspection. The DESIGN/BUILD FIRM will notify in writing of all particulars in which this inspection reveals that the Work is incomplete, non-conforming or defective. Construction Manager shall immediately take such measures as are necessary to complete such Work or remedy such deficiencies and shall notify all Parties that the Project (or designated portion thereof) is finally complete.

After Project Manager will then instruct DESIGN/BUILD FIRM to prepare and deliver to the Project Manager a Certificate of Final Completion which shall establish the date of Final Completion for the Project (or that portion of the Project). After review of the certificate by the Project Manager, CITY shall either accept or reject the certificate. Acceptance of Final Completion by CITY shall be based upon compliance with the Contract Documents and Applicable Laws. DESIGN/BUILD FIRM shall have thirty (30) days to complete the items listed therein. Warranties required by the Contract Documents and submitted in appropriate form to the Project Manager along with the request for Final Completion shall commence on the date of Final Completion of the Project (or for that portion of the Project). The Certificate of Final Completion shall be submitted to CITY through the Project Manager and DESIGN/BUILD FIRM for its written acceptance of the responsibilities assigned to it in such certificate.

ARTICLE 21 - SHOP DRAWINGS AND SCHEDULE OF VALUES

- 21.1 DESIGN/BUILD FIRM shall submit Shop Drawings for all equipment, apparatus, machinery, fixtures, piping, wiring, fabricated structures and manufactured articles. The purpose of a Shop Drawing is to show the suitability, efficiency, technique of manufacture, installation requirements, details of the item and evidence of its compliance or noncompliance with the Contract Documents.
- 21.2 DESIGN/BUILD FIRM shall thoroughly review and check the Shop Drawings and each and every copy shall show DESIGN/BUILD FIRM's approval thereon.
- 21.3 If the Shop Drawings show or indicate departures from the Contract requirements, DESIGN/BUILD FIRM shall make specific mention thereof in its shop drawing submittal and a separate letter. Failure to point out such departures shall not relieve DESIGN/BUILD FIRM from its responsibility to comply with the Contract Documents. Project Manager shall determine acceptability of change and, in considering said change, may require data, technical comparisons, cost comparisons, quality comparisons and/or calculations to determine the equality of deviations. Contract Administrator is not obligated to accept deviations.
- 21.4 No acceptance will be given to partial submittal of Shop Drawings for items which interconnect and/or are interdependent. It is DESIGN/BUILD FIRM's responsibility to assemble the Shop Drawings for all such interconnecting and/or independent items, check them, and then make one (1) submittal to the Project Manager, along with DESIGN/BUILD FIRM's comments as to compliance, noncompliance, or features requiring special attention.
- 21.5 If catalog sheets or prints of manufacturers' standard drawings are submitted as Shop Drawings, any additional information or changes on such drawings shall be typewritten or lettered in ink.

Catalog sheet with multiple options shall be highlighted to depict specific pertinent data including options.

- 21.6 DESIGN/BUILD FIRM shall submit to Project Manager five (5) copies. Re-submissions of Shop Drawings shall be made in the same quantity until final acceptance is obtained.
- 21.7 Project Manager's acceptance of the Shop Drawings, as approved by DESIGN/BUILD FIRM, will be for general compliance with the Plans and Specifications, and shall not relieve DESIGN/BUILD FIRM of responsibility for the accuracy of such Drawings, nor for the proper fittings and construction of the Work, nor for the furnishing of the materials or Work required by the Agreement and not indicated on the Drawings.
- 21.8 DESIGN/BUILD FIRM shall keep one (1) set of Shop Drawings, marked with the Project Manager's acceptance, as the Project site at all times.
- 21.9 The DESIGN/BUILD FIRM shall submit a Schedule of Values to the Project Manager as specified in the Technical Specifications. DESIGN/BUILD FIRM shall submit to the Project Manager a separate Schedule of Values for demolition, abatement, and site work ten (10) calendar days prior to commencing such portion of the Work. The schedule will be typed on 8 ½" x 11" white paper listing: title of Project, location, Project number, Consultant, Contractor, Contract designation and date of submission. The schedule shall list the installed value of the component parts of the Work in sufficient detail to serve as a basis for computing values for progress payments during the construction. The table of contents of the specifications shall establish the format for listing the component items. Each line item will be identified by the number and title of the respective major section of the specifications. For each line item, DESIGN/BUILD FIRM shall list the sub-values of major products or operations under the item. Each item shall include the proportion of DESIGN/BUILD FIRM's overhead and profit. For any items for which progress payments will be requested for stored materials, the value will be broken down with:
- A. Schedule must include the following but is not limited to:
 - Separate identifiable activity on the critical path, an activity labeled "Other Conditions Allowance." This activity duration shall be thirty (30) calendar days and inserted at the end of the schedule prior to Substantial Completion. This allowance may or may not be used at the discretion of the CITY. Use of this activity shall be subject to the review and approval of the CITY and the Design Criteria Professional. The duration of the "Other Conditions Allowance" activity shall be reduced as other conditions are experienced and inserted in the schedule;
 - B. The cost of materials delivered, unloaded, properly stored and safeguarded, with taxes paid; and
 - C. The total installed value review.

ARTICLE 22 - FIELD ENGINEERING

- 22.1 The DESIGN/BUILD FIRM shall provide and pay for field engineering services required for the Project. This Work shall include the following elements:
- A. Survey work required in execution of the Project;
 - B. Civil, structural or other professional engineering, architectural, landscape

architectural, or land surveying services specified, or required to execute the DESIGN/BUILD FIRM's construction methods;

- C. The survey completed by DESIGN/BUILD FIRM will identify the qualified engineer or registered land surveyor, acceptable to the CITY, and he or she shall be retained by the DESIGN/BUILD FIRM at the outset of this Project;
- D. The survey will locate and protect control points prior to starting site work, and will preserve all permanent reference points during construction;
- E. No changes or relocations will be made without prior written notice to the Project Manager;
- F. A written report shall be made to the Project Manager when any reference point is lost or destroyed, or requires relocation because of necessary changes in grades or locations;
- G. The surveyor shall be required to replace Project control points which may be lost or destroyed. The surveyor shall be duly registered as a surveyor or mapper, as required by state law;
- H. Replacement shall be established based upon original survey control.

22.2 The survey completed by DESIGN/BUILD FIRM will identify the qualified engineer or registered land surveyor, acceptable to the CITY, and he or she shall be retained by the DESIGN/BUILD FIRM at the outset of this Project.

22.2.1 The survey will locate and protect control points prior to starting sitework, and will preserve all permanent reference points during construction.

22.2.2 No changes or relocations will be made without prior written notice to the Project Manager.

22.2.3 A written report shall be made to the Project Manager when any reference point is lost or destroyed or requires relocation because of necessary changes in grades or locations.

22.2.4 The surveyor shall be required to replace Project control points which maybe lost or destroyed. The surveyor shall be duly registered as a surveyor or mapper, as required by state law.

22.2.5 Replacements shall be established based upon original survey control.

ARTICLE 23 - FIELD LAYOUT OF THE WORK AND RECORD DRAWINGS

23.1 The entire responsibility for establishing and maintaining a line and grade in the field lies with DESIGN/BUILD FIRM. DESIGN/BUILD FIRM shall maintain an accurate and precise horizontal and vertical record of the existing pavement conditions; final pavement conditions; and all pipelines, conduits, structures, underground utility access portals, handholes, fittings, etc. encountered or installed during construction. DESIGN/BUILD FIRM shall deliver these records in good order to the Contract Administrator as the Work is completed. These records shall serve as a basis for "as-built" drawings. The cost of all such field layout and recording work is included in the Contract Price.

23.2 DESIGN/BUILD FIRM shall maintain in a safe place at the site, one (1) record copy of the

Plans and Specifications, addenda, written amendments, Change Orders and written interpretations and clarifications, in good order and annotated to show all changes made during construction. These record documents, together with all approved samples and a counterpart of all approved Shop Drawings, will be available to Contract Administrator for reference. Upon completion of the Project, these record documents, samples and Shop Drawings shall be delivered to Contract Administrator.

- 23.3 At the completion of the Project, the DESIGN/BUILD FIRM shall turn over to the CITY a set of reproducible drawings and a complete set of all drawings in the latest version of AutoCAD on Compact Disk, not compressed, which accurately reflect the "as-built" conditions of the new facilities. All changes made to the Construction Documents, either as clarifications or as changes, will be reflected in the plans. The changes shall be submitted at least monthly to the Project Manager. These "as-built" drawings are to be AutoCAD version 2018 and to CITY Standard Details and CADD Standards. Format media must be delivered and found to be acceptable prior to final payments.

ARTICLE 24 - NO DAMAGES FOR DELAY

- 24.1 NO CLAIM FOR DAMAGES OR ANY CLAIM OTHER THAN FOR AN EXTENSION OF TIME SHALL BE MADE OR ASSERTED AGAINST CITY BY REASON OF ANY DELAYS. DESIGN/BUILD FIRM shall not be entitled to an increase in the Contract Price or payment or compensation of any kind from CITY for direct, indirect, consequential, impact, or other costs, expenses or damages including, but not limited to, costs of acceleration or inefficiency arising because of delay, disruption, interference or hindrance from any cause whatsoever, whether such delay, disruption, interference, or hindrance be reasonable or unreasonable, foreseeable or unforeseeable, or avoidable or unavoidable; provided, DESIGN/BUILD FIRM hindrances or delays are not due solely to fraud, bad faith or active interference by the CITY, DESIGN/BUILD FIRM shall be entitled only to extensions of the Contract Time as the sole and exclusive remedy for such resulting delays, in accordance with and to the extent specifically provided above. The specific application of this Article to other provisions of this Agreement shall not be construed as a limitation of any sort upon the further application of this Article. Ten Dollars (\$10.00) of DESIGN/BUILD FIRM's fee is acknowledged as separate and independent consideration for the covenants contained in this Article.

ARTICLE 25- LIMITATION OF LIABILITY

- 25.1 The CITY desires to enter into this Agreement only if in so doing the CITY can place a limit on the CITY's liability for any cause of action arising out of this Agreement, so that the CITY's liability for any breach never exceeds the sum of \$1,000.00. For other good and valuable consideration, the receipt and sufficiency of which is hereby acknowledged, the DESIGN/BUILD FIRM hereby expresses its willingness to enter into this Agreement with the knowledge that the DESIGN/BUILD FIRM's recovery from the CITY to any action or claim arising from the Agreement is limited to a maximum amount of \$1,000.00, which amount shall be reduced by the amount actually paid by the CITY to the DESIGN/BUILD FIRM pursuant to this Agreement, for any action or claim arising out of this Agreement. Nothing contained in this paragraph or elsewhere in this Agreement is in any way intended either to be a waiver

of the limitation placed upon the CITY's liability beyond the limits established in Section 768.28, Florida Statutes; and no claim or award against the CITY shall include attorney's fees, investigative costs, expert fees, suit costs or pre-judgment interest.

ARTICLE 26 - GOVERNING LAW

- 26.1 This Agreement shall be interpreted and construed in accordance with and governed by the laws of the State of Florida. Any controversies or legal problems arising out of this Agreement and any action involving the enforcement or interpretation of any rights hereunder shall be submitted to the exclusive jurisdiction of the State courts of the Seventeenth Judicial Circuit of Broward County, Florida, the venue situs, and shall be governed by the laws of the State of Florida. To encourage prompt and equitable resolution of any litigation that may arise hereunder, DESIGN/BUILD FIRM SHALL SPECIFICALLY BIND ITS PROJECT TEAM MEMBERS AND ANY AND ALL SUBCONTRACTORS TO THE PROVISIONS OF THE AGREEMENT.

ARTICLE 27 - MISCELLANEOUS PROVISIONS

- 27.1 **OWNERSHIP OF DOCUMENTS:** All finished or unfinished documents, data, studies, surveys, drawings, maps, models, photographs, specifications, plans and reports prepared or provided by DESIGN/BUILD FIRM in connection with this Agreement shall become the property of CITY, whether the Project for which they are made is completed or not, shall become the property of CITY and shall be delivered by DESIGN/BUILD FIRM to Project Manager within fifteen (15) days of the receipt of the written notice of termination or upon completion of the Project. If applicable, CITY may withhold payments then due to DESIGN/BUILD FIRM until DESIGN/BUILD FIRM complies with the provisions of this section.
- 27.2 **AUDIT RIGHT AND RETENTION OF RECORDS:** CITY shall have the right to audit the books, records, and accounts of DESIGN/BUILD FIRM that are related to this Project. DESIGN/BUILD TEAM shall keep such books, records, and accounts as may be necessary in order to record complete and correct entries related to the Project. DESIGN/BUILD FIRM shall preserve and make available, at reasonable times for examination and audit by CITY, all financial records, supporting documents, statistical records, and any other documents pertinent to this Agreement for the required retention period of the Florida Public Records Act, Chapter 119, Florida Statutes, or, if the Florida Public Records Act is not applicable, for a minimum period of three (3) years after termination of this Agreement. If any audit has been initiated and audit findings have not been resolved at the end of the retention period or three (3) years, whichever is longer, the books, records, and accounts shall be retained until resolution of the audit findings. If the Florida Public Records Act is determined by CITY to be applicable to DESIGN/BUILD FIRM's records, DESIGN/BUILD FIRM shall comply with all requirements thereof; however, no confidentiality or non-disclosure requirement of either federal or state law shall be violated by DESIGN-BUILD FIRM. Any incomplete or incorrect entry in such books, records, and accounts shall be a basis for CITY's disallowance and recovery of any payment upon such entry.
- 27.3 **ARCHITECT/ENGINEER:** DESIGN/BUILD FIRM shall use the architect/engineer,

including subconsultants, identified in the proposal that were a material part of the selection of the DESIGN/BUILD TEAM to provide the services for this Project. DESIGN/BUILD FIRM shall obtain written approval of CITY's Public Works Director prior to changing or modifying the list of subconsultants submitted by the DESIGN/BUILD FIRM. SEE APPENDICES attached hereto and made a part hereof.

- 27.4 **ASSIGNMENT AND PERFORMANCE:** Neither this Agreement nor any interest herein shall be assigned, transferred, or encumbered without the prior written consent of the other Party.
- 27.5 **ONE ORIGINAL AGREEMENT:** This Agreement will be executed in one original.
- 27.6 **ALL PRIOR AGREEMENTS SUPERSEDED:** This Agreement incorporates and includes all prior negotiations, correspondence, conversations, agreements or understandings applicable to the matters contained herein; and the Parties agree that there are no commitments, agreements or understandings concerning the subject matter of this Agreement that are not contained in this Agreement. Accordingly, the Parties agree that no deviation from the terms hereof shall be predicated upon any prior representations or agreements whether oral or written.
- 27.7 **AMENDMENTS:** No modification, amendment, or alteration in the terms or conditions contained herein shall be effective unless contained in a written document executed by both Parties with the same formality and of equal dignity herewith.
- 27.8 **INDEPENDENT CONTRACTOR:** DESIGN/BUILD FIRM is an independent contractor under this Agreement. Services provided by DESIGN/BUILD FIRM shall be subject to the supervision of DESIGN/BUILD FIRM. In providing the services, DESIGN/BUILD FIRM or its agents shall not be acting and shall not be deemed as acting as officers, employees, or agents of the CITY. No partnership, joint venture, or other joint relationship is created hereby. CITY does not extend to DESIGN/BUILD FIRM or its agents any authority of any kind to bind CITY in any respect whatsoever.
- 27.9 **THIRD PARTY BENEFICIARIES:** Neither DESIGN/BUILD FIRM or CITY intends to directly or substantially benefit a third party by this Agreement. The Parties expressly acknowledge that it is not their intent to create any rights or obligations in any third person or entity under this Agreement. Therefore, the Parties agree that there are no third party beneficiaries to this Agreement and that no third party shall be entitled to assert a claim against either of them based upon this Agreement.
- 27.10 **WAIVER OF BREACH AND MATERIALITY:** Failure by the CITY or DESIGN/BUILD FIRM to enforce any provision of this Agreement shall not be deemed a waiver of such provision or modification of this Agreement.
- 27.11 **MATERIAL TERM:** CITY and DESIGN/BUILD FIRM agree that each requirement, duty, and obligation set forth herein is substantial and important to the formation of this Agreement, and therefore, is a material term hereof.
- 27.12 **COMPLIANCE WITH LAWS:** DESIGN/BUILD FIRM shall comply with all federal, state, and local laws, codes, ordinances, rules and regulations in performing its duties, responsibilities, and obligations related to this Agreement.

- 27.13 **NONDISCRIMINATION, EQUAL EMPLOYMENT OPPORTUNITY, AND AMERICANS WITH DISABILITIES ACT:** DESIGN/BUILD FIRM shall not unlawfully discriminate against any person in its operations and activities in its use or expenditure of the funds or any portion of the funds provided by this Agreement and shall affirmatively comply with all applicable provisions of the Americans with Disabilities Act in the course of providing any services funded in whole or in part by CITY, including Titles 1 and 11 of the Act, and all applicable regulations, guidelines and standards.

DESIGN/BUILD FIRM's decisions regarding the delivery of work and services under this Agreement shall be made without regard to or consideration of race, age, religion, color, gender, sexual orientation, national origin, marital status, physical or mental disability, political affiliation, or any other factor which cannot be lawfully or appropriately used as a basis for service delivery.

DESIGN/BUILD FIRM shall comply with Title 1 of the Americans with Disabilities Act regarding nondiscrimination on the basis of disability in employment and further shall not discriminate against any employee or applicant for employment because of race, age, religion, color, gender, sexual orientation, national origin, marital status, political affiliation, or physical or mental disability. In addition, DESIGN/BUILD FIRM shall take affirmative steps to ensure nondiscrimination in employment against disabled persons. Such actions shall include, but not be limited to, the following: employment, upgrading, demotion, transfer, recruitment or recruitment advertising, layoff, termination, rates of pay, other forms of compensation, terms and conditions of employment, training (including apprenticeship) and accessibility.

DESIGN/BUILD FIRM shall take affirmative action to ensure that applicants are employed and employees are treated without regard to race, age, religion, color, gender, sexual orientation, national origin, marital status, political affiliation, or physical or mental disability during employment. Such actions shall include, but not be limited to, the following: employment, upgrading, demotion, transfer, recruitment or recruitment advertising, layoff, termination, rates of pay, other forms of compensation, terms and conditions of employment, training (including apprenticeship) and accessibility.

- 27.14 **PUBLIC ENTITY CRIMES ACT:** In accordance with the Public Entity Crimes Act, Sec. 287.133, Florida Statutes, a person or affiliate who is a contractor, consultant or other provider, who has been placed on the convicted vendor list following a conviction for a Public Entity Crime, may not submit a bid on a contract to provide any goods or services to the CITY, may not submit a bid on a contract with the CITY for the construction or repair of a public building or public work, may not submit bids on leases of real property to the CITY, may not be awarded or perform work as a contractor supplier, subcontractor or consultant under a contract with the CITY and may not transact any business with the CITY in excess of the threshold amount provided in Section 287.017, Florida Statutes, as amended, for category two purchases for a period of thirty-six (36) months from the date of being placed on the convicted vendor list. Violation of this Section shall result in cancellation of the CITY purchase and may result in debarment
- 27.15 **SEVERANCE:** In the event a portion of this Agreement is found by a court of competent jurisdiction to be invalid, the remaining provisions shall continue to be effective unless CITY elects to terminate this Agreement. The election to terminate this Agreement based upon this provision shall be made within seven (7) days after the finding by the court becomes final.

27.16 **JOINT PREPARATION:** Preparation of this Agreement has been a joint effort of the CITY and DESIGN/BUILD FIRM and the resulting document shall not, solely as a matter of judicial construction, be construed more severely against one of the Parties than any other.

27.17 **PRIORITY OF PROVISIONS:** If there is a conflict or inconsistency between any term, statement, requirement, or provision of any exhibit attached hereto, any document or events referred to herein, or any document incorporated into this Agreement by reference and a term, statement, requirement, or provision of this Agreement, the term, statement, requirement, or provision contained in Articles 1 through 21 shall prevail and be given effect.

In the event of a conflict among the Contract Documents, the most stringent requirement shall control.

27.18 **TAXES:** DESIGN/BUILD FIRM shall pay all applicable sales, consumer, use and other taxes as required by law. DESIGN/BUILD FIRM is responsible for reviewing the pertinent state statutes involving state taxes and complying with all requirements. All such taxes that are required as of the time of Agreement execution shall be included in the Not-To-Exceed Guaranteed Maximum Price.

27.19 **SCRUTINIZED COMPANIES:** Subject to *Odebrecht Construction, Inc., v. Prasad*, 876 F.Supp.2d 1305 (S.D. Fla. 2012), affirmed, *Odebrecht Construction, Inc., v. Secretary, Florida Department of Transportation*, 715 F.3d 1268 (11th Cir. 2013), with regard to the “Cuba Amendment,” the Contractor certifies that it is not on the Scrutinized Companies with Activities in Sudan List or the Scrutinized Companies with Activities in the Iran Petroleum Energy Sector List, and that it does not have business operations in Cuba or Syria, as provided in Section 287.135, Florida Statutes (2021), as may be amended or revised. The Contractor certifies that it is not on the Scrutinized Companies that Boycott Israel List created pursuant to Section 215.4725, Florida Statutes (2021), as may be amended or revised, and that it is not engaged in a boycott of Israel. The City may terminate this Agreement at the City’s option if the Contractor is found to have submitted a false certification as provided under subsection (5) of Section 287.135, Florida Statutes (2021), as may be amended or revised, or been placed on the Scrutinized Companies with Activities in Sudan List or the Scrutinized Companies with Activities in the Iran Petroleum Energy Sector List or the Scrutinized Companies that Boycott Israel List created pursuant to Section 215.4725, Florida Statutes (2021), as may be amended or revised, or is engaged in a boycott of Israel or has been engaged in business operations in Cuba or Syria, as defined in Section 287.135, Florida Statutes (2021), as may be amended or revised.

27.20 **PUBLIC RECORDS:**

IF THE DESIGN/BUILD FIRM HAS QUESTIONS REGARDING THE APPLICATION OF CHAPTER 119, FLORIDA STATUTES, TO THE DESIGN/BUILD FIRM’S DUTY TO PROVIDE PUBLIC RECORDS RELATING TO THIS CONTRACT, CONTACT THE CUSTODIAN OF PUBLIC RECORDS AT CITY CLERK’S OFFICE, 100 N. ANDREWS AVENUE, FORT LAUDERDALE, FLORIDA, 33301, EMAIL: PRRCONTRACT@FORTLAUDERDALE.GOV,

PHONE: 954-828- 5002.

DESIGN/BUILD FIRM shall:

- 27.20.1 Keep and maintain public records required by the CITY in order to perform the service. Upon request from the CITY's custodian of public records, provide the CITY with a copy of the requested records or allow the records to be inspected or copied within a reasonable time at a cost that does not exceed the cost provided in Chapter 119, Florida Statutes (2022), as may be amended or revised, or as otherwise provided by law.
 - 27.20.2 Ensure that public records that are exempt or confidential and exempt from public records disclosure requirements are not disclosed except as authorized by law for the duration of the contract term and following completion of this contract if the DESIGN/BUILD FIRM does not transfer the records to the CITY.
 - 27.20.3 Upon completion of the Agreement, transfer, at no cost, to the CITY all public records in possession of the DESIGN/BUILD FIRM or keep and maintain public records required by the CITY to perform the service. If the DESIGN/BUILD FIRM transfers all public records to the CITY upon completion of this Agreement, the DESIGN/BUILD FIRM shall destroy any duplicate public records that are exempt or confidential and exempt from public records disclosure requirements. If the DESIGN/BUILD FIRM keeps and maintains public records upon completion of this Agreement, the DESIGN/BUILD FIRM shall meet all applicable requirements for retaining public records. All records stored electronically must be provided to the CITY, upon request from the CITY's custodian of public records, in a format that is compatible with the information technology systems of the CITY.
 - 27.20.4 If the DESIGN/BUILD FIRM keeps and maintains public records upon completion of this Agreement, the DESIGN/BUILD FIRM shall meet all applicable requirements for retaining public records. All records stored electronically must be provided to the CITY, upon request from the CITY's custodian of public records, in a format that is compatible with the information technology systems of the CITY.
- 27.21 E-VERIFY
- As a condition precedent to the effectiveness of this Agreement, pursuant to Section 448.095, Florida Statutes (2023), as may be amended or revised, the Contractor and its subcontractors shall register with and use the E-Verify system to electronically verify the employment eligibility of newly hired employees.
1. The Contractor shall require each of its subcontractors, if any, to provide the Contractor with an affidavit stating that the subcontractor does not employ, contract with, or subcontract with an unauthorized alien. The Contractor shall maintain a copy of the subcontractor's affidavit for the duration of this Agreement and in accordance with the public records requirements of this Agreement.
 2. The City, the Contractor, or any subcontractor who has a good faith belief that a person

or entity with which it is contracting has knowingly violated Subsection 448.09(1), Florida Statutes (2023), as may be amended or revised, shall terminate the contract with the person or entity.

3. The City, upon good faith belief that a subcontractor knowingly violated the provisions of Subsection 448.095(5), Florida Statutes (2023), as may be amended or revised, but that the Contractor otherwise complied with Subsection 448.095(5), Florida Statutes (2023), as may be amended or revised, shall promptly notify Contractor and order the Contractor to immediately terminate the contract with the subcontractor, and the Contractor shall comply with such order.

4. A contract terminated under Subparagraph 448.095(5)(c)1. or 2., Florida Statutes (2023), as may be amended or revised, is not a breach of contract and may not be considered as such. If the City terminates this contract under Paragraph 448.095(5)(c), Florida Statutes (2023), as may be amended or revised, the Contractor may not be awarded a public contract for at least one year after the date on which the contract was terminated. The Contractor is liable for any additional costs incurred by the City as a result of termination of this Agreement.

5. Contractor shall include in each of its subcontracts, if any, the requirements set forth in this Section, including this subparagraph, requiring any and all subcontractors, as defined in Subsection 448.095(1)(e), Florida Statutes (2023), as may be amended or revised, to include all of the requirements of this Section in their subcontracts. Contractor shall be responsible for compliance by any and all subcontractors, as defined in Subsection 448.095(1)(e), Florida Statutes (2023), as may be amended or revised, with the requirements of Section 448.095, Florida Statutes (2023), as may be amended or revised.

[THIS SPACE WAS INTENTIONALLY LEFT BLANK]

CITY

IN WITNESS OF THE FOREGOING, the Parties have set their hands and seals the day and year first written above.

CITY OF FORT LAUDERDALE, a Florida
municipal corporation

By: _____
GREG CHAVARRIA
City Manager

Date: _____

ATTEST:

By: _____
DAVID R. SOLOMAN
City Clerk

Approved as to Legal Form and correctness:
Thomas Ansbro, City Attorney

By: _____
RHONDA MONTOYA HASAN
Assistant City Attorney

Sample Agreement

CONTRACTOR

WITNESSES:

CONTRACTOR.,
a Florida company/corporation.

By: _____

Print Name: _____

Title: _____

ATTEST:

(CORPORATE SEAL)

STATE OF _____:

COUNTY OF _____:

The foregoing instrument was acknowledged before me by means of physical presence or online notarization, this _____ day of _____, 2024, by _____ (NAME OF AUTHORIZED OFFICER), as _____, (TITLE OF AUTHORIZED OFFICER), for _____, (NAME OF COMPANY), a Florida _____ (TYPE OF COMPANY).

(Signature of Notary Public - State of Florida)

(Print, Type, or Stamp Commissioned Name of Notary Public)

Personally Known _____ OR Produced Identification _____
Type of Identification Produced: _____

SURETY BOND

IN COMPLIANCE WITH AND INCORPORATING THE PROVISIONS OF SECTION 255.05, FLORIDA STATUTES

THIS IS A SURETY BOND given by _____ the "Contractor" as principal, referred to in this Bond as "Contractor" and _____ as "Surety," and they represent by this instrument that they are bound to the CITY OF FORT LAUDERDALE, a municipal corporation of the State of Florida ("City"), in the sum of _____ for the payment of which, to be made to the City of Fort Lauderdale, Florida, they jointly and severally, bind themselves and each of their heirs, executors, administrators, successors and assigns.

Owner Name: CITY OF FORT LAUDERDALE
a municipal corporation of the State of Florida

Owner Address and Telephone: Public Works Department
101 NE 3rd Avenue, Suite 1410
Fort Lauderdale, Florida 33301
(954) 828-5772

Bond No.: _____

Contractor Name, Address, Telephone: _____

Surety Company, Address, Telephone: _____

City Project No./Bid No.: _____

Name of Project: _____

Project Location: City of Fort Lauderdale

Legal Description and Street Address: _____

Description of Work: _____

"Contractor" is bound by an instrument in writing dated the _____ day of _____, by which Contractor has contracted with the City of Fort Lauderdale, Florida, to furnish labor, tools, and materials for the Project referenced and described above, together with all work incidental thereto, as fully set out in the plans, specifications and details on file in the Office of the City Engineer of the City.

Notice required by Section 255.05(6), Florida Statutes (2023): "This bond is given to comply with Section 255.05 Florida Statutes (2023), and any action instituted by a claimant under this bond for payment must be in accordance with the notice and time limitation provisions in Section 255.05(2), Florida Statutes (2023)."

The condition of the above obligation is such that if the above bound "Contractor," or its successor or assigns shall in good faith and in good, sufficient, substantial and workmanlike manner, perform the work and comply with the conditions of the contract, including payment of penalties, in strict accordance with the terms and provisions stipulated in it and shall indemnify and hold harmless the City against and for payments of any and all damages that may happen to persons or property by reason of excavations, embankments, obstructions and all other work in streets, alleys or places in connection with the work, or arising out of any act, neglect or omission of the "Contractor" or its agents, servants, or employees with relation to the work, and shall indemnify and hold

harmless the City against and from all suits and acts of every nature and description arising out of any claims by patentees of any process connected with the work agreed to be performed under the contract, or of any materials used upon the work, and pay all costs accruing if the contract is cancelled and a new contract for finishing the work is let, and all other expenses lawfully chargeable to the "Contractor," then this agreement shall be null and void; otherwise it is to remain in full force and effect, but it is expressly provided, understood and agreed that if the "Contractor" or its subcontractors fail to duly and promptly pay for any labor, material, or other supplies used by "Contractor" or any of its subcontractors in the performance of the work to be done, or the Contractor defaults in its Contract with the City, the "Surety" will promptly pay to all claimants, as defined in Section 255.05(1), Florida Statutes (2023), the same in an amount not exceeding the sum specified in this bond, together with interest at the rate of fifteen percent (15%) per annum, and the Surety hereby stipulates and agrees that no change, extension, reduction, alteration or addition to the terms of the contract or the plans, details and specifications shall in any way affect the obligations of this bond.

Whenever Contractor shall be, and is declared by the City to be in default under the contract, the City may proceed to cancel the contract and award a new contract for finishing the work or order the Surety to promptly remedy the default by obtaining a bid or bids for completing the contract in accordance with the original contract terms and conditions. Upon the determination by the City of the lowest responsible bidder, the Surety shall complete all work and pay the full cost of completion, less previous payments.

This Bond is effective for one (1) year after completion and acceptance of the work, with liability equal to twenty-five percent (25%) of the contract price, and is so conditioned that the "Contractor" will, at its own expense, correct any defective or faulty work or material which appears within one (1) year after completion of the work and final payment, upon notification by the City.

IN WITNESS WHEREOF, the above "Contractor" has signed this Agreement, and the "Surety" has caused this Agreement to be signed in its name by its Attorney-in-Fact, and its corporate seal affixed, this ____ day of _____, 2024.

Signed, sealed and delivered
in the presence of:

CONTRACTOR:

(Witness) Signature

(SEAL)

(Witness) Print Name

Print Name and Title

(SEAL)

SURETY:

(Witness) Signature

Local Agent

(SEAL)

(Witness) Print Name

Print Name and Title

(SEAL)

ADDENDUM NO. 1

RFQ No. 209

Design Build Services for G. T. Lohmeyer WWTP Odor Control Improvements

ISSUED: February 26, 2024

This addendum is being issued to make the following change(s):

1. Additional Drawings - 100-E WWTP Exp Admin Elec Clar 10&11 SPS3 & LOX misc. pipe 1980
2. Additional Drawings – 11781 GTL WWTP ROS - RECORD DRAWINGS - SIGNED
3. Additional Drawings – 2020-01-07 P12172 E- One-Line Diagram
4. Additional Drawings – 2020-12-23 GTL Complete As-Built Diagram
5. Additional AutoCAD Drawings – Electrical Drawings
6. Additional AutoCAD Drawings – Survey Drawings
7. Instruments to be replaced for Pretreat-SHT
8. Technical Memoranda - 20200831_GTL Odor Control Assessment - TM_Rev
9. Approved Shop Drawings - 07 54 00-GAF EverGuard TPO Roof System (Approved SUM-00039)

The City of Fort Lauderdale GTL WWTP is a secured facility and is exempt from the Public Records Law, pursuant to FL Statute Chapter 119.071.

In order to obtain plans for the project, log into the City's online strategic sourcing platform, complete a City of Fort Lauderdale Plans Request Form, and submit it to the City in accordance with instructions contained therein.

Pursuant to Subsection 119.071(3)(b), Florida Statutes (2022), building plans, blueprints, schematic drawings, and diagrams, including draft, preliminary, and final formats, which depict the internal layout and structural elements of

the facility/location (collectively "Plans") are exempt from public inspection and copying except to a licensed architect, engineer, or contractor who is performing work on or related to the project. **The entities and persons receiving the Plans shall maintain the exempt status of the Plans.**

All other terms, conditions, and specifications remain unchanged.

Michelle Lemire
Procurement Administrator

Company Name: _____
(please print)

Bidder's Signature: _____

Date: _____

ADDENDUM NO. 2

RFQ No. 209

Design Build Services for G. T. Lohmeyer WWTP Odor Control Improvements

ISSUED: **March 13, 2024**

This addendum is being issued to make the following change(s):

1. Additional Drawings - GTL - Fiber Optic Cable Routes and Patch Panel Connections
2. Additional Information - GTL - GTL - PLC 1A_1B IO List
3. Additional Drawings - GTL - GTL Existing FO routes
4. Additional Drawings - VPSA - Fiber Patch Panels

The following are changes and clarifications to Section 4, Scope of Work, 4.3.1 Pretreatment Building. Words in ~~strikethrough~~ type are deletions from existing text. Words in **bold underlined** type are additions to existing text.

5. **The overhead crane on the 3rd floor of Pretreatment is not required to be replaced. Prepare and paint the beams that support the crane and perform a full overhaul of the two crane mechanisms per the manufacturer's recommendation.**
6. **The 8 skylights on the roof of Pretreatment are not required to be replaced. Remove, protect, reseal all areas with waterproof sealant, repaint, and reinstall after roofing work is completed.**
7. **Replace all non-LED light fixtures in the Pretreatment building with LED of equal or great Lumens.**
8. **Replace A/C and ductwork on the 2nd Floor Hallway outside locker rooms and in the lunchroom.**
9. **Replace all panelboards in the Pretreatment Building including conduit, conductors from their power source and to the final instrument, light, etc. The goal of this project is to remove all original red electrical conduit and junction boxes in the entire building.**

10. **Relocate City's existing Champion Air Compressor south of the influent sampler on the 1st floor and reconnect to instrument airline feeding LOX Storage**
11. The following specific requirements are also added for the replacement PLC in the project.
 - I. **Replace existing Control Panel complete, including, but not limited to:**
 - a. **Design and Installation of new Control Panel.**
 - b. **NEMA 12 Enclosure, with key-locking mechanism.**
 - c. **Control Panel back plate (no side panels allowed), and necessary electrical/wiring components (terminal block, fused terminals, breakers, wire ducts, etc.)**
 - d. **Necessary conduits, power and control wires and cables. When possible, avoid penetrating the top of the Enclosure. All conduits must be sealed against water and humidity intrusion.**
 - e. **Allen Bradley Redundant ControlLogix Programmable Logic Controller hardware, including 20% prewired spare I/O.**
 - f. **Allen Bradley Stratix network switch, with minimum 4 10/100 Copper ports + 2 SFP 10/100 ports**
 - g. **Fiber Optics Patch Panel and required connections.**
 - h. **Battery backup with minimum 1 hour runtime capacity, and standard replaceable batteries.**
 - i. **Front-door mounted Windows 10 Industrial PC workstation (e.g., Phoenix Contact, Maple Systems)**
 - j. **Keyboard/touchpad combo (Hope Industrial, p/n: KB-R3-WMT-BLK-4-USB)**
 - II. **PLC programming, complete and operational.**
 - III. **Installation, Commissioning and Startup**

IV. Operations and Maintenance Manual (O&M)

- a. Two hard copies**
- b. One electronic copy**

V. Control Panel Schematics

VI. Copy of PLC Program in Studio 5000 native format

VII. Spare Parts (10% of total used in Project)

- a. Relays**
- b. Breakers**
- c. Fuses**
- d. Terminal Blocks**
- e. Power supply**

VIII. Given that the existing PLCs are in operation, the demolition of the old Control Panels, and/or the transferring of the controls from the old PLCs to the new Control Panel must be made within a reasonable time frame and with minimal interruptions to the Treatment Process. To accomplish this, the temporary transfer of critical IO signals from one PLC to the other might be required. The Contractor responsible for this Upgrade shall coordinate with the GTL Engineer/Project Manager to discuss the critical elements of each Process/PLC, time constraints, shutdowns, and other potential issues that might affect proper operation of the system. The Contractor must provide a Plan (on a Process/PLC basis) detailing the steps that will be taken to address the GTL Engineer/Project Manager's concerns resulting from this discussion.

12. The Proposal Due Date has been changed to Friday, May 3, 2024, at 2:00PM Local Time.

The City of Fort Lauderdale GTL WWTP is a secured facility and is exempt from the Public Records Law, pursuant to FL Statute Chapter 119.071.

In order to obtain plans for the project, log into the City's online strategic sourcing platform, complete a City of Fort Lauderdale Plans Request Form, and submit it to the City in accordance with instructions contained therein.

Pursuant to Subsection 119.071(3)(b), Florida Statutes (2022), building plans, blueprints, schematic drawings, and diagrams, including draft, preliminary, and final formats, which depict the internal layout and structural elements of the facility/location (collectively "Plans") are exempt from public inspection and copying except to a licensed architect, engineer, or contractor who is performing work on or related to the project. **The entities and persons receiving the Plans shall maintain the exempt status of the Plans.**

All other terms, conditions, and specifications remain unchanged.

Michelle Lemire
Procurement Administrator

Company Name:

(please print)

Bidder's Signature:

Date: _____

ADDENDUM NO. 3

RFQ No. 209

Design Build Services for G. T. Lohmeyer WWTP Odor Control Improvements

ISSUED: April 4, 2024

This addendum is being issued to make the following change(s):

1. Additional Document – Surety Bond Template

The City of Fort Lauderdale GTL WWTP is a secured facility and is exempt from the Public Records Law, pursuant to FL Statute Chapter 119.071.

In order to obtain plans for the project, log into the City's online strategic sourcing platform, complete a City of Fort Lauderdale Plans Request Form, and submit it to the City in accordance with instructions contained therein.

Pursuant to Subsection 119.071(3)(b), Florida Statutes (2022), building plans, blueprints, schematic drawings, and diagrams, including draft, preliminary, and final formats, which depict the internal layout and structural elements of the facility/location (collectively "Plans") are exempt from public inspection and copying except to a licensed architect, engineer, or contractor who is performing work on or related to the project. **The entities and persons receiving the Plans shall maintain the exempt status of the Plans.**

All other terms, conditions, and specifications remain unchanged.

Michelle Lemire
Procurement Administrator

Company Name: _____
(please print)

Bidder's Signature: _____

Date: _____

ADDENDUM NO. 4

RFQ No. 209

Design Build Services for G. T. Lohmeyer WWTP Odor Control Improvements

ISSUED: April 12, 2024

This addendum is being issued to make the following change(s):

The following are changes and clarifications to Section 4, Scope of Work, 4.3.1 Pretreatment Building. Words in strikethrough type are deletions from existing text. Words in bold underlined type are additions to existing text.

1. The number of lights to be purchased by the Contractor in accordance with Addendum No. 3 has been reduced. The City purchased CodeMaster LED Sealed lights (See attached spec sheet) in 2022 for the Pretreatment Building 3rd Floor. Contractor shall install the City owned lights on the 3rd floor, which are not motion controlled. The 3rd floor shall be controlled via a minimum of 4 switches. The new 1st and 2nd floor light fixtures shall have individual motion sensors. Contractor shall provide 3 spares for each type of light installed.
2. **Contractor shall install four (4) 1-inch empty conduits for future use from the MCC/PLC to the Pretreatment Building 1st floor interior south wall near the existing fiberglass chemical tanks.**

All other terms, conditions, and specifications remain unchanged.

Michelle Lemire
Procurement Administrator

Company Name: _____
(please print)

Bidder's Signature: _____

Date: _____

Code•Master™ LED Factory Sealed Luminaires

Explosionproof, Dust-Ignitionproof

NEC/CEC:

Class I, Division 1 and 2, Groups B, C, D ①
 Class I, Zone 1, Groups IIA, IIB, IIB + H₂
 Class II, Division 1, Group E, F, G
 Class II, Division 2, Group F, G

NEC/CEC:

Class III
 Simultaneous Exposure
 Type 3R, 4X
 IP66/67

NEC/CEC:

Suitable for Use in Wet Locations
 Marine Outside Type (Salt Water) ⌘
 Approved for use in Paint Spray Booths

Applications

- Explosionproof fixtures suitable for use in:
 - A wide range of hazardous areas where ignitable vapors, dust, moisture and corrosive elements are present
 - Areas where access to relamp is difficult, reliability is essential, and environment is costly to maintain. Consistent light levels maintained regardless of cold temperatures
 - Areas requiring frequent on-and-off of lights or power cycling- no warm up time required
 - Type 4X, marine, wet locations and hose-down environments
 - Areas with high energy costs- Code•Master LED consumes 50% or more less power than its HID equivalent
- Typical applications include:
 - Chemical
 - Oil, Gas, and Petrochemical
 - Pulp and Paper
 - Foundries
 - Manufacturing
 - Waste and sewage treatment
 - Pharmaceutical
 - Mining
 - Power Generation
 - Paint Spray Booths

Features

- Fixture operates safely in high ambient temperatures -40 °C up to +65 °C (-40 °F up to +149 °F)
- 60,000+ hours rated life eliminates the need for frequent relamping

Nominal Lumens ②	HID Equivalent	Model Number
3,700	100W	CMLED10
5,400	150W	CMLED15
7,900	175W	CMLED17
10,000	250W	CMLED25
11,600	350W	CMLED35
13,600	400W	CMLED40
16,700	600W	CMLED75
19,300	750W	CMLED90

- Choice of color temperature (CCT): 5000K cool white, 4000K neutral white or 3000K warm white.
- Choice of optics for optimal light distribution in a variety of applications, NEMA Type V and Type V Wide.
- Arrangement of heat-producing components results in more efficient heat dissipation for cooler fixture operation.
- All threaded joints are flame-tight.
- Fixture housing and mounting hoods are copperfree cast aluminum with baked epoxy finish. All exposed hardware is stainless steel.
- Aluminum body utilizes the same Code•Master HID mounting hoods, and is an easy retrofit for existing Code•Master HID installations; can be pendant, ceiling, wall, or stanchion mounted.
- Acme double-lead threads speed installation and fixture removal from mounting hood – only half as many turns are required as for single-lead threads. The threads do not stick or gall, eliminating the troublesome problems often encountered with single lead threads during fixture unit removal.



- Safe, easy servicing without disconnecting any wiring. “Wireless” fixture unit easily threads off mounting hood for convenient servicing or for immediate replacement with a “stand-by” unit.
- Factory sealed. External seals not required.
- Globe and driver are all field replaceable.
- LED arrays generate light outputs from 2,100 to 19,000+ lumens (an equivalent of 70 W HID to 750 W HID lamps) providing exceptional efficacy
- Choice of replaceable clear or diffused glass globe.
- Universal, high efficiency, drivers cover voltage requirements for 120-277 Vac 50/60 Hz, 125-300 Vdc and 347-480 Vac, 50/60 Hz, Volts +/- 10%.
- 6KV standard surge suppression for 347-480 Vac and 120-277 Vac input.
- Photometric data and electronic drawings available upon request.
- Approved for use in paint spray booths.

Standard Materials

- Mounting hoods and bodies: cast copperfree (4/10 of 1% max.) aluminum
- All hardware, catch assemblies and yoke bracket: stainless steel
- Gaskets: silicone
- Globe: explosionproof glass

Standard Finishes

- Mounting hoods, bodies, and guards: baked gray epoxy clad finish, electrostatically applied for complete uniform protection

Options

- Safety cable, add suffix **-C**.
- Lens guard, add suffix **-G**.
- Fusing, add suffix **-F** ⌘.

NEC/CEC Certifications and Compliances

- UL Standard: UL 50, UL 50E, UL 844, UL 1598, UL 1598A, UL 8750
- CSA Standard: CAN/CSA-C22.2 No. 94.1-07 (R2012), CAN/CSA-C22.2 No. 94.2-07 (R2012), CAN/CSA-C22.2 No. 137-M1981 (R2009), CAN/CSA-C22.2 No. 250.0-08 (R2013), CAN/CSA-C22.2 No. 250.13, CAN/CSA-C22.2 No. 60529-05 (R2010)
- ANSI Standard: ANSI/IEC 60529
- cCSAus Certified: 70030675

① Complete Code•Master LED luminaire consists of fixture unit and a mounting hood. For Group B applications a Group B rated mounting hood must be used.

② Nominal light value for 5000K clear glass globe.

⌘ Use of a fuse voids Marine Outside Type (Salt Water) rating.

Code•Master™ LED Factory Sealed Luminaires

Explosionproof, Dust-Ignitionproof

NEC/CEC:

Class I, Division 1 and 2, Groups B, C, D ①
Class I, Zone 1, Groups IIA, IIB, IIB + H₂
Class II, Division 1, Group E, F, G
Class II, Division 2, Group F, G

NEC/CEC:

Class III
Simultaneous Exposure
Type 3R, 4X
IP66/67

NEC/CEC:

Suitable for Use in Wet Locations
Marine Outside Type (Salt Water) ⌘
Approved for use in Paint Spray Booths

Illustrated Features

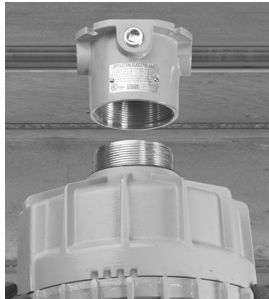

Mounting Hood Compatibility

Code•Master LED is compatible with existing Code•Master mounting hoods. For easy installation, install and wire the mounting hood and simply thread in fixture. Double lead Acme threads are provided for ease of installation.



Rugged and Durable Housing

Mounting hoods and bodies are copper free aluminum with baked epoxy-clad finish, electrostatically applied for complete uniform protection.



Optional Safety Cable

Provides secondary retention for lighting fixtures.



Driver Assembly

Driver can be easily accessed and replaced.



Optional Fusing *

Fuse kit includes fuse, fuse holder and necessary hardware for field installation.



Optional Trunion/Yoke Mount

Trunion/yoke mount allows the fixture to be aimed in a desired position.



Replaceable Globe Assembly

The replaceable globe assembly is available with clear or diffuse glass.



Optional Wire Guard

Stainless steel wire guard can be used for additional protection.

① Complete Code•Master LED luminaire consists of fixture unit and a mounting hood. For Group B applications a Group B rated mounting hood must be used.
⌘ Use of a fuse voids Marine Outside Type (Salt Water) rating.

Code•Master™ LED Factory Sealed Luminaires

Explosionproof, Dust-Ignitionproof

NEC/CEC:
 Class I, Division 1 and 2, Groups B, C, D ①
 Class I, Zone 1, Groups IIA, IIB, IIB + H₂
 Class II, Division 1, Group E, F, G
 Class II, Division 2, Group F, G

NEC/CEC:
 Class III
 Simultaneous Exposure
 Type 3R, 4X
 IP66/67

NEC/CEC:
 Suitable for Use in Wet Locations
 Marine Outside Type (Salt Water) ⌘
 Approved for use in Paint Spray Booths

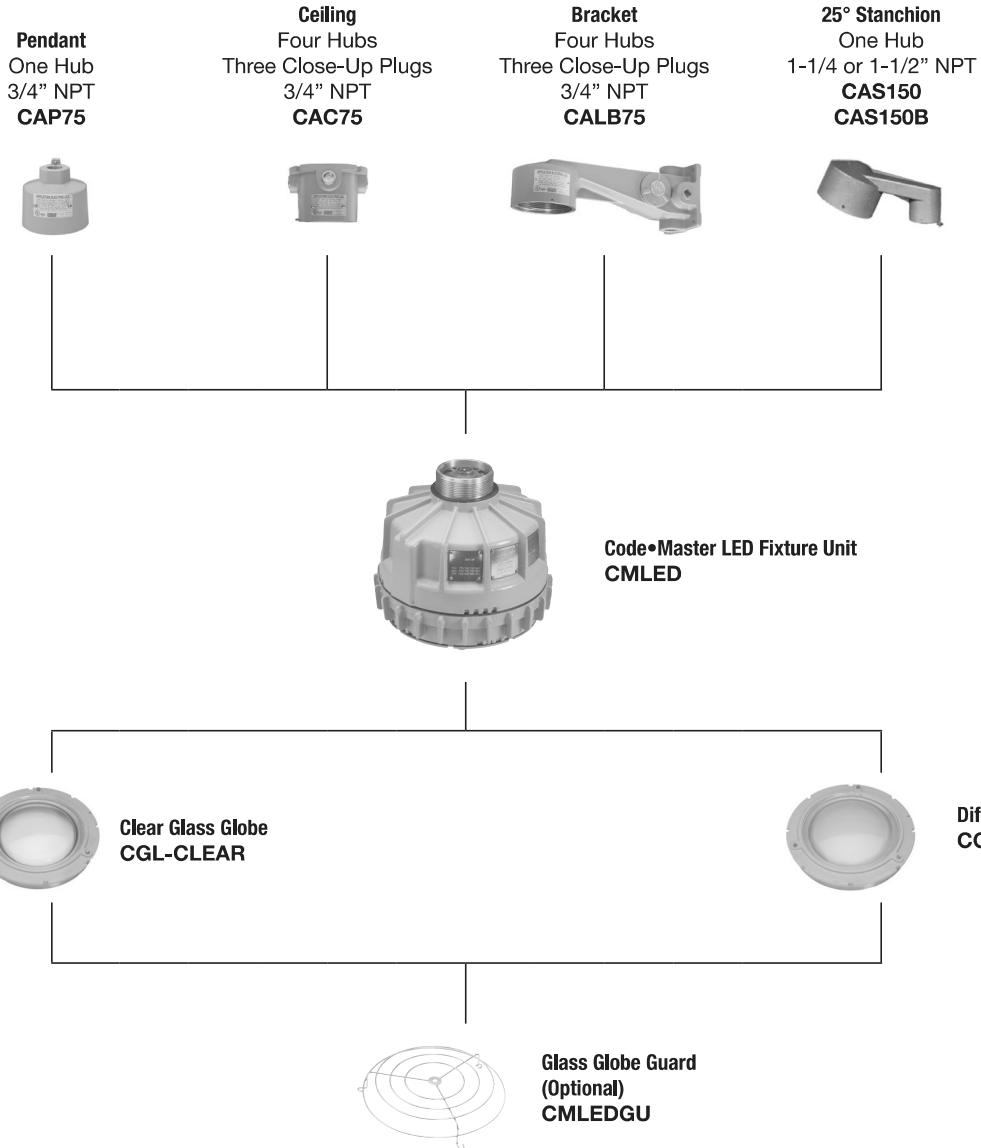

LED/AREA: NEC/CEC EXPLOSIONPROOF

APPLETON™

① When using the 25° Stanchion mounting hood in group B applications part number CAS-150B must be used.
 ⌘ Use of a fuse voids Marine Outside Type (Salt Water) rating.

Code•Master™ LED Factory Sealed Luminaires

Explosionproof, Dust-Ignitionproof

NEC/CEC:

Class I, Division 1 and 2, Groups B, C, D ①
 Class I, Zone 1, Groups IIA, IIB, IIB + H₂
 Class II, Division 1, Group E, F, G
 Class II, Division 2, Group F, G

NEC/CEC:

Class III
 Simultaneous Exposure
 Type 3R, 4X
 IP66/67

NEC/CEC:

Suitable for Use in Wet Locations
 Marine Outside Type (Salt Water) ⌘
 Approved for use in Paint Spray Booths

Order using catalog numbering guides below or select catalog number from tables on following pages.

Catalog Numbering Guide

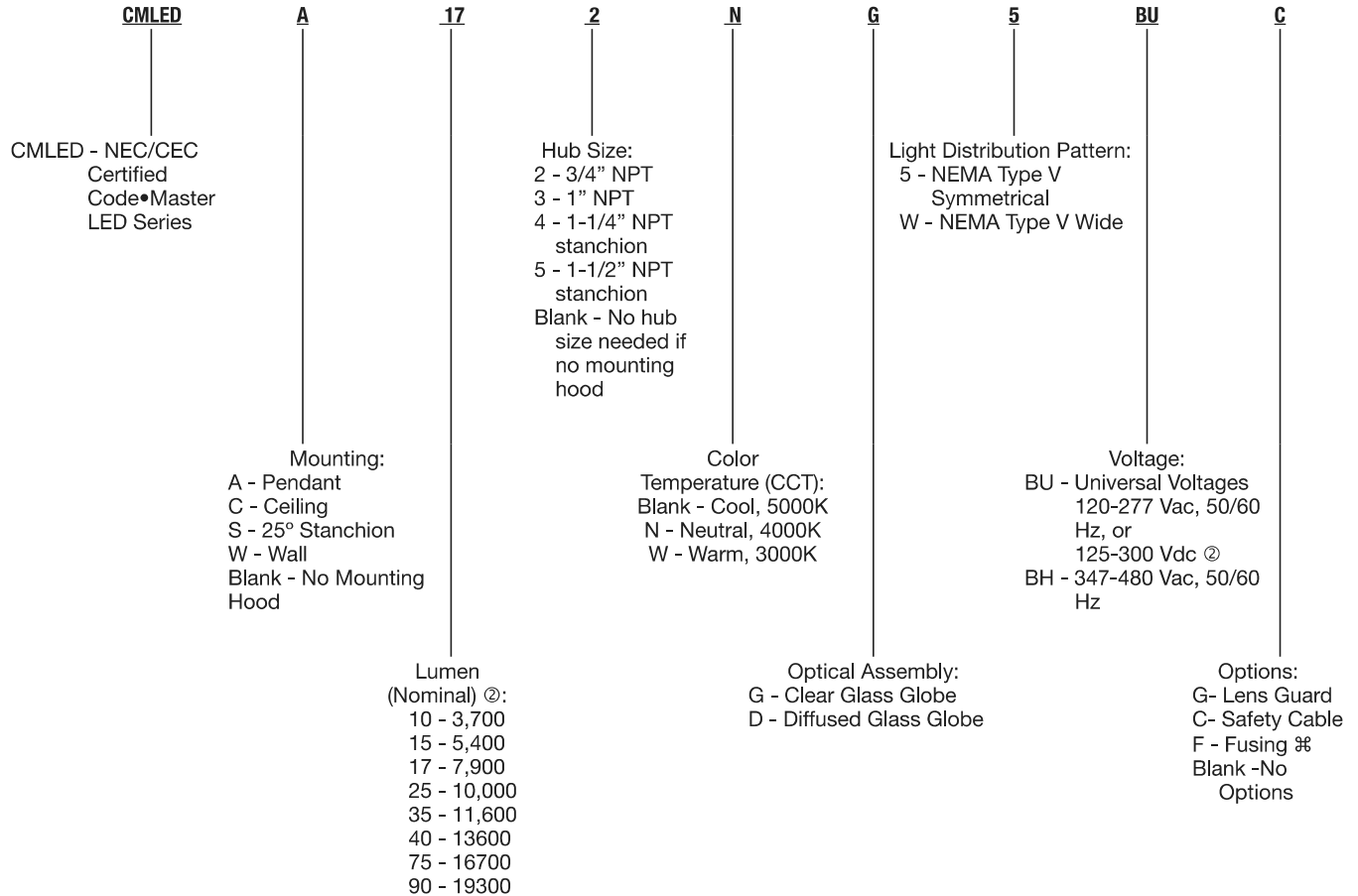

LED / AREA: NEC/CEC EXPLOSIONPROOF
APPLETON™

① Complete Code•Master LED luminaire consists of fixture unit and a mounting hood. For Group B applications a Group B rated mounting hood must be used.
 ② Nominal light value for 5000K clear glass globe.
 ⌘ Use of a fuse voids Marine Outside Type (Salt Water) rating.

Code•Master™ LED Factory Sealed Luminaires

Explosionproof, Dust-Ignitionproof

NEC/CEC:

Class I, Division 1 and 2, Groups B, C, D ①
 Class I, Zone 1, Groups IIA, IIB, IIB + H₂
 Class II, Division 1, Group E, F, G
 Class II, Division 2, Group F, G

NEC/CEC:

Class III
 Simultaneous Exposure
 Type 3R, 4X
 IP66/67

NEC/CEC:

Suitable for Use in Wet Locations
 Marine Outside Type (Salt Water) ‡
 Approved for use in Paint Spray Booths

LED/AREA: NEC/CEC EXPLOSIONPROOF

APPLETON™

Type ②	Ambient Temperature C° (F°)	Supply Wire Temperature C° (F°)	Class I, Division 1 (Gas)	Class I, Zone 1 (Gas)	Class II Division 1 (Dust) & Simultaneous Exposure
CMLED10	40 (104)	90 (104)	T6	T6	T6
	55 (131)	90 (104)	T6	T6	T6
	65 (140)	90 (104)	T6	T6	T6
CMLED15	40 (104)	90 (104)	T6	T6	T6
	55 (131)	90 (104)	T6	T6	T6
	65 (140)	90 (104)	T6	T6	T6
CMLED17	40 (104)	90 (104)	T6	T6	T6
	55 (131)	90 (104)	T6	T6	T6
	65 (140)	90 (104)	T5	T5	T5
CMLED25	40 (104)	90 (104)	T6	T6	T6
	55 (131)	90 (104)	T6	T6	T5
	65 (140)	90 (104)	T5	T5	T5
CMLED35	40 (104)	90 (104)	T6	T6	T6
	55 (131)	90 (104)	T5	T5	T75
	65 (140)	90 (104)	T5	T5	T4A
CMLED40	40 (104)	90 (104)	T6	T6	T6
	55 (131)	90 (104)	T5	T5	T5
	65 (140)	90 (104)	T4A	T4	T4A
CMLED75	40 (104)	90 (104)	T5	T5	T5
	55 (131)	90 (104)	T5	T5	T4A
	65 (140)	90 (104)	T4A	T4	T4A
CMLED90	40 (104)	90 (104)	T5	T5	T4A
	55 (131)	90 (104)	T4A	T4	T4A

“T” Numbers Represent the Maximum Surface Temperature for Class I, Division 1 locations and Maximum Surface Temperature Under Dust Blanket for Class II, Division 1 Locations.

“T” #	T1	350	325	T2	T2A	T2B	T2C	T2D	T3	T3A	T3B	T3C	T4	T4A	T5	T6
Temp. Range °C (°F)	351-450 (664-842)	326-350 (619-662)	301-325 (574-617)	281-300 (538-572)	261-280 (502-536)	231-260 (448-500)	216-230 (421-446)	201-215 (394-419)	181-200 (358-392)	166-180 (331-356)	161-165 (322-329)	136-160 (277-320)	121-135 (250-275)	101-120 (214-248)	86-100 (187-212)	85 (185)

① Complete Code•Master LED luminaire consists of fixture unit and a mounting hood. For Group B applications a Group B rated mounting hood must be used.

② T-Codes are using the “APMS” drivers.

‡ Use of a fuse voids Marine Outside Type (Salt Water) rating.

Code•Master™ LED Factory Sealed Luminaires

Explosionproof, Dust-Ignitionproof

NEC/CEC:

Class I, Division 1 and 2, Groups B, C, D ①
 Class I, Zone 1, Groups IIA, IIB, IIB + H₂
 Class II, Division 1, Group E, F, G
 Class II, Division 2, Group F, G

NEC/CEC:

Class III
 Simultaneous Exposure
 Type 3R, 4X
 IP66/67

NEC/CEC:

Suitable for Use in Wet Locations
 Marine Outside Type (Salt Water) ⌘
 Approved for use in Paint Spray Booths

Lumen Output for Clear Glass Globe

		Lumen Output (Efficacy) for Clear Glass Globe ②							
		CMLED10	CMLED15	CMLED17	CMLED25	CMLED35	CMLED40	CMLED75	CMLED90
Type V	5000K CCT, 70 CRI	3700 (123)	5400 (120)	7900 (132)	10000 (130)	11600 (128)	13600 (131)	16700 (126)	19300 (123)
Type V Wide	5000K CCT, 70 CRI	3300 (108)	5000 (112)	7200 (120)	8900 (117)	10400 (115)	11800 (114)	14500 (110)	16700 (106)
Type V	4000K CCT, 80 CRI	3600 (117)	5100 (115)	7900 (131)	9900 (130)	11600 (128)	13500 (131)	16600 (127)	19300 (122)
Type V Wide	4000K CCT, 80 CRI	3300 (108)	4700 (105)	7100 (118)	8800 (115)	10300 (113)	11600 (112)	14200 (109)	16400 (105)
Type V	3000K CCT, 80 CRI	3200 (106)	4600 (104)	7200 (120)	9100 (119)	10600 (117)	12000 (117)	14700 (112)	17100 (109)
Type V Wide	3000K CCT, 80 CRI	3000 (97)	4200 (95)	6500 (108)	8000 (105)	9400 (103)	10600 (103)	13000 (99)	15000 (95)

		Lumen Output (Efficacy) for Diffused Glass Globe							
		CMLED10	CMLED15	CMLED17	CMLED25	CMLED35	CMLED40	CMLED75	CMLED90
Type V	5000K CCT, 70 CRI	3200 (106)	4600 (104)	6500 (109)	8300 (108)	9600 (106)	11200 (109)	13700 (104)	15800 (101)
Type V Wide	5000K CCT, 70 CRI	2600 (84)	3900 (88)	5700 (95)	7100 (92)	8300 (91)	9400 (91)	11500 (88)	13200 (84)
Type V	4000K CCT, 80 CRI	3100 (100)	4400 (99)	6500 (109)	8200 (107)	9600 (106)	11200 (108)	13700 (104)	15700 (100)
Type V Wide	4000K CCT, 80 CRI	2600 (84)	3700 (83)	5600 (94)	7000 (91)	8200 (90)	9200 (90)	11300 (86)	13100 (83)
Type V	3000K CCT, 80 CRI	2800 (91)	4000 (89)	5900 (99)	7500 (98)	8800 (96)	9900 (96)	12200 (93)	14100 (90)
Type V Wide	3000K CCT, 80 CRI	2300 (76)	3300 (75)	5200 (86)	6400 (84)	7500 (82)	8500 (82)	10400 (79)	12000 (76)

① Complete Code•Master LED luminaire consists of fixture unit and a mounting hood. For Group B applications a Group B rated mounting hood must be used.
 ② All lumen values are typical (tolerance +/- 10%).
 ⌘ Use of a fuse voids Marine Outside Type (Salt Water) rating.

LED / AREA: NEC/CEC EXPLOSIONPROOF
APPLETON™

Code•Master™ LED Factory Sealed Luminaires

Explosionproof, Dust-Ignitionproof

NEC/CEC:

Class I, Division 1 and 2, Groups B, C, D ①
 Class I, Zone 1, Groups IIA, IIB, IIB + H₂
 Class II, Division 1, Group E, F, G
 Class II, Division 2, Group F, G

NEC/CEC:

Class III
 Simultaneous Exposure
 Type 3R, 4X
 IP66/67

NEC/CEC:

Suitable for Use in Wet Locations
 Marine Outside Type (Salt Water) ⌘
 Approved for use in Paint Spray Booths

Electrical Specifications

Model Number	Voltage Suffix	Voltage	Input Power (Watts)	Input Current (Amp)	Power Factor (PF)	Total Harmonic Distortion (THD)
CMLED10	BU	120 Vac	30	0.26	>.95	<20%
		277 Vac	31	0.12	>.90	<20%
		125 Vdc	31	0.25	N/A	N/A
		300 Vdc	31	0.10	N/A	N/A
	BH	347 Vac	32	0.09	>.95	<20%
		480 Vac	32	0.07	>.90	<20%
CMLED15	BU	120 Vac	45	0.38	>.99	<20%
		277 Vac	44	0.17	>.95	<20%
		125 Vdc	45	0.36	N/A	<20%
		300 Vdc	45	0.15	N/A	<20%
	BH	347 Vac	45	0.13	>.95	<20%
		480 Vac	45	0.10	>.95	<20%
CMLED17	BU	120 Vac	60	0.50	>.99	<20%
		277 Vac	59	0.24	>.90	<20%
		125 Vdc	60	0.98	N/A	<20%
		300 Vdc	60	0.20	N/A	<20%
	BH	347 Vac	60	0.18	>.95	<20%
		480 Vac	60	0.14	>.90	<20%
CMLED25	BU	120 Vac	76	0.64	>.99	<20%
		277 Vac	75	0.29	>.90	<20%
		125 Vdc	77	0.62	N/A	<20%
		300 Vdc	76	0.25	N/A	<20%
	BH	347 Vac	78	0.23	>.95	<20%
		480 Vac	78	0.17	>.90	<20%
CMLED35	BU	120 Vac	91	0.76	>.99	<20%
		277 Vac	89	0.34	>.95	<20%
		125 Vdc	91	0.73	N/A	<20%
		300 Vdc	89	0.30	N/A	<20%
	BH	347 Vac	91	0.27	>.99	<20%
		480 Vac	91	0.20	>.95	<20%

① Complete Code•Master LED luminaire consists of fixture unit and a mounting hood. For Group B applications a Group B rated mounting hood must be used.

⌘ Use of a fuse voids Marine Outside Type (Salt Water) rating.

Code•Master™ LED Factory Sealed Luminaires

Explosionproof, Dust-Ignitionproof

NEC/CEC:

Class I, Division 1 and 2, Groups B, C, D ①
 Class I, Zone 1, Groups IIA, IIB, IIB + H₂
 Class II, Division 1, Group E, F, G
 Class II, Division 2, Group F, G

NEC/CEC:

Class III
 Simultaneous Exposure
 Type 3R, 4X
 IP66/67

NEC/CEC:

Suitable for Use in Wet Locations
 Marine Outside Type (Salt Water) ⌘
 Approved for use in Paint Spray Booths

Electrical Specifications

Model Number	Voltage Suffix	Voltage	Input Power (Watts)	Input Current (Amp)	Power Factor (PF)	Total Harmonic Distortion (THD)
CMLED40	BU	120 Vac	103	0.85	>.95	<20%
		277 Vac	98	0.39	>.90	<20%
		125 Vdc	101	0.81	N/A	N/A
		300 Vdc	98	0.33	N/A	N/A
	BH	347 Vac	102	0.30	>.99	<20%
		480 Vac	102	0.22	>.95	<20%
CMLED75	BU	120 Vac	132	1.10	>.99	<20%
		277 Vac	126	0.48	>.90	<20%
		125 Vdc	130	1.04	N/A	N/A
		300 Vdc	126	0.42	N/A	N/A
	BH	347 Vac	130	0.38	>.99	<20%
		480 Vac	130	0.28	>.95	<20%
CMLED90	BU	120 Vac	157	1.35	>.99	<20%
		277 Vac	155	0.58	>.90	<20%
		125 Vdc	161	1.29	N/A	N/A
		300 Vdc	156	0.52	N/A	N/A
	BH	347 Vac	159	0.46	>.99	<20%
		480 Vac	158	0.33	>.95	<20%

LED / AREA: NEC/CEC EXPLOSIONPROOF

APPLETON™

① Complete Code•Master LED luminaire consists of fixture unit and a mounting hood. For Group B applications a Group B rated mounting hood must be used.
 ⌘ Use of a fuse voids Marine Outside Type (Salt Water) rating.

Code•Master™ LED Factory Sealed Luminaires



Explosionproof, Dust-Ignitionproof

NEC/CEC:
 Class I, Division 1 and 2, Groups B, C, D ①
 Class I, Zone 1, Groups IIA, IIB, IIB + H₂
 Class II, Division 1, Group E, F, G
 Class II, Division 2, Group F, G

NEC/CEC:
 Class III
 Simultaneous Exposure
 Type 3R, 4X
 IP66/67

NEC/CEC:
 Suitable for Use in Wet Locations
 Marine Outside Type (Salt Water) ⌘
 Approved for use in Paint Spray Booths

Mounting Hoods

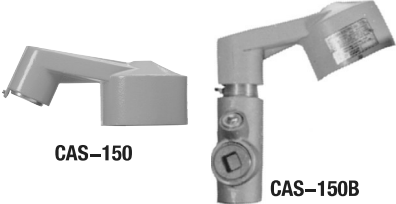
		Hub Size Inches	Certified for Class I, Division 1 and 2, Group	cULus Certified	Catalog Number
Pendant					
 CAP-75 & CAP-100	One Hub	3/4		B, C, D	CAP-75
		1		B, C, D	CAP-100
Ceiling					
	Four hubs, Three Close-Up Plugs	3/4		B, C, D	CAC-75
		1		B, C, D	CAC-100
Bracket					
	Four hubs, Three Close-Up Plugs	3/4		B, C, D	CALB-75
		1		B, C, D	CALB-100
25° Stanchion					
 CAS-150	One Hub	1-1/4 or 1-1/2 ②		C, D	CAS-150
		1-1/2		B, C, D	CAS-150B ①

① When using the 25° Stanchion mounting hood in group B applications part number CAS-150B must be used.

② 1-1/2" tapped hub furnished with 1-1/2" to 1-1/4" reducer.

⌘ Use of a fuse voids Marine Outside Type (Salt Water) rating.

Code•Master™ LED Factory Sealed Luminaires

Explosionproof, Dust-Ignitionproof

NEC/CEC:

Class I, Division 1 and 2, Groups B, C, D ①
 Class I, Zone 1, Groups IIA, IIB, IIB + H₂
 Class II, Division 1, Group E, F, G
 Class II, Division 2, Group F, G







NEC/CEC:

Class III
 Simultaneous Exposure
 Type 3R, 4X
 IP66/67

NEC/CEC:

Suitable for Use in Wet Locations
 Marine Outside Type (Salt Water) ⌘
 Approved for use in Paint Spray Booths

Accessories and Replacement Parts

	Description	Catalog Number
Fuse Kits ⌘		
	5 Amp Fuse Kit	CMLEDF-5
Globes and Gaskets		
	Clear Globe Assembly	CGL-CLEAR
	Diffused Globe Assembly	CGL-DIFF
	Stainless Steel Wire Guard	CMLEDGU
	Safety Cable	CMLEDSC
	Yoke Bracket	CMLEDYOKE

LED / AREA: NEC/CEC EXPLOSIONPROOF

APPLETON™

① Complete Code•Master LED luminaire consists of fixture unit and a mounting hood. For Group B applications a Group B rated mounting hood must be used.
 ⌘ Use of a fuse voids Marine Outside Type (Salt Water) rating.

Code•Master™ LED Factory Sealed Luminaires

Explosionproof, Dust-Ignitionproof

NEC/CEC:

Class I, Division 1 and 2, Groups B, C, D ①
 Class I, Zone 1, Groups IIA, IIB, IIB + H₂
 Class II, Division 1, Group E, F, G
 Class II, Division 2, Group F, G



NEC/CEC:

Class III
 Simultaneous Exposure
 Type 3R, 4X
 IP66/67

NEC/CEC:

Suitable for Use in Wet Locations
 Marine Outside Type (Salt Water) ⌘
 Approved for use in Paint Spray Booths

Replacement Drivers

	Voltage	Driver Wattage	Luminaire Model	Constant Current Settings	Catalog Number
	BU	50 Watt	CMLED10	500mA	APMS050C135UD50
	BH				APMS050C135HD50
	BU	50 Watt	CMLED15	780mA	APMS050C135UD75
	BH				APMS050C135HD75
	BU	100 Watt	CMLED17	360mA	APMS100C105UD37
	BH				APMS100C105HD37
	BU	100 Watt	CMLED25	480mA	APMS100C105UD48
	BH				APMS100C105HD48
	BU	100 Watt	CMLED35	595mA	APMS100C105UD57
	BH				APMS100C105HD57
	BU	150 Watt	CMLED40	650mA	APMS150C105UD65
	BH				APMS150C105HD65
	BU	150 Watt	CMLED75	820mA	APMS150C105UD82
	BH				APMS150C105HD82
	BU	150 Watt	CMLED90	960mA	APMS150C105UD98
	BH				APMS150C105HD98

Replacement Drivers for fixtures without "Model A" marking on label

	Description	Catalog Number
	120 - 277 V Driver (70 thru 250 Watt equivalent only)	CMLEDBU
	347 - 480 V Driver (70 thru 350 Watt equivalent only)	CMLEDBH
	120 - 277 V Driver (400 Watt equivalent only)	CMLEDBU40

① Complete Code•Master LED luminaire consists of fixture unit and a mounting hood. For Group B applications a Group B rated mounting hood must be used.

② BU = 120 - 277 Vac, 50/60 Hz or 125 - 300 Vdc; BU = 347 - 480, 50/60 Hz.

⌘ Use of a fuse voids Marine Outside Type (Salt Water) rating.

Code•Master™ LED Factory Sealed Luminaires

Explosionproof, Dust-Ignitionproof

NEC/CEC:

Class I, Division 1 and 2, Groups B, C, D ^①
 Class I, Zone 1, Groups IIA, IIB, IIB + H₂
 Class II, Division 1, Group E, F, G
 Class II, Division 2, Group F, G

NEC/CEC:

Class III
 Simultaneous Exposure
 Type 3R, 4X
 IP66/67

NEC/CEC:

Suitable for Use in Wet Locations
 Marine Outside Type (Salt Water) [⌘]
 Approved for use in Paint Spray Booths

Dimensions in Millimeters (Inches)

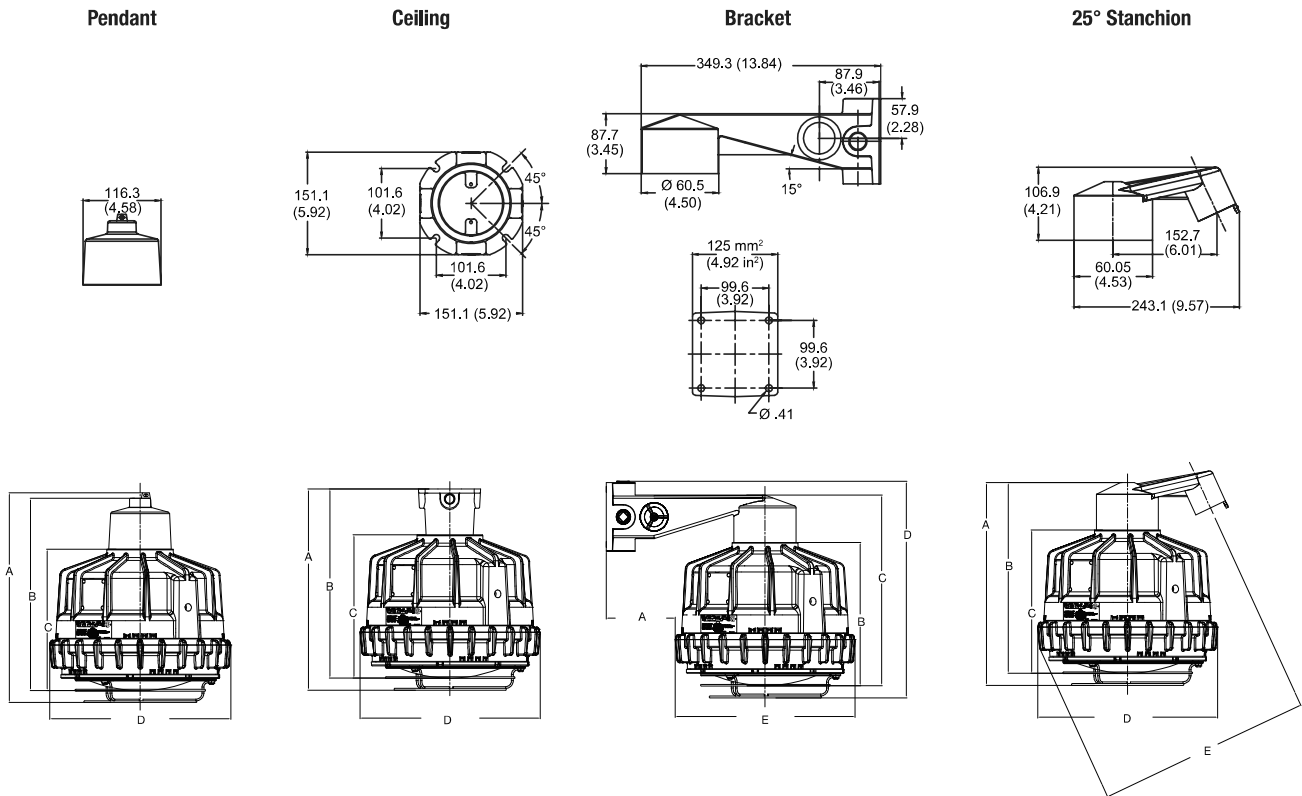

Pendant				Ceiling				Bracket					25° Stanchion				
A	B	C	D	A	B	C	D	A	B	C	D	E	A	B	C	D	E
384.0	352.0	259.0	331.0	364.0	342.0	259.0	331.0	127.0	259.0	344.0	391.0	331.0	366.0	344.0	259.0	331.0	392.0
(15.1)	(13.9)	(10.2)	(13.0)	(14.3)	(13.5)	(10.2)	(13.0)	(5.0)	(10.2)	(13.6)	(15.4)	(13.0)	(14.4)	(13.6)	(10.2)	(13.0)	(15.4)

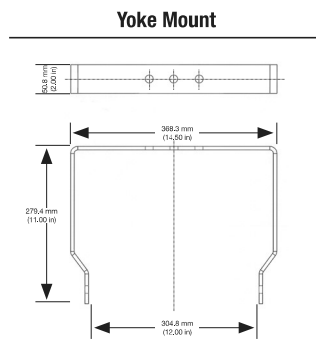
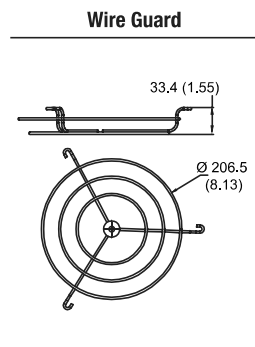

Weights

Description	Weight kg (lb)
Fixture Unit (Ballast Housing)	17.2 (38)
Pendant Mounting Hood	0.9 (2)
Ceiling Mounting Hood	1.8 (4)
Wall Mounting Hood	2.7 (6)
25° Stanchion Mounting Hood	0.9 (2)
Wire Guard	0.45 (1)

^① Complete Code•Master LED luminaire consists of fixture unit and a mounting hood. For Group B applications a Group B rated mounting hood must be used.
[⌘] Use of a fuse voids Marine Outside Type (Salt Water) rating.

Code•Master™ LED Factory Sealed Luminaires

Explosionproof, Dust-Ignitionproof

NEC/CEC:

Class I, Division 1 and 2, Groups B, C, D ①
 Class I, Zone 1, Groups IIA, IIB, IIB + H₂
 Class II, Division 1, Group E, F, G
 Class II, Division 2, Group F, G

NEC/CEC:

Class III
 Simultaneous Exposure
 Type 3R, 4X
 IP66/67

NEC/CEC:

Suitable for Use in Wet Locations
 Marine Outside Type (Salt Water) ⌘
 Approved for use in Paint Spray Booths

Photometric Data — DATA SHOWN IS ABSOLUTE

Type V, Clear Glass, 5000K CCT
 REPORT NUMBER: CMLLED10G5BU

POLAR CANDELA DISTRIBUTION

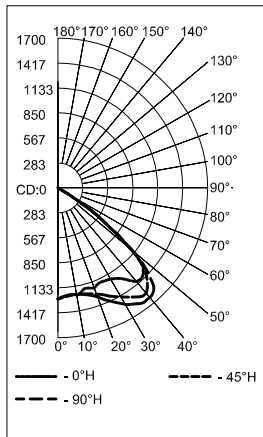

ISOFOOT CANDLE PLOT

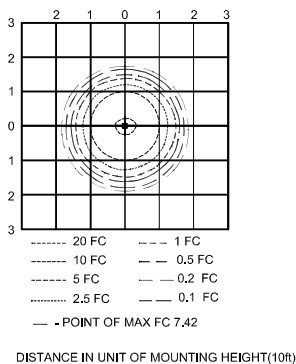

ZONAL LUMEN SUMMARY

Zone	Lumens	% Luminaire
0-30	1,090.3	29.2%
0-40	2,043.9	54.7%
0-60	3,677.9	98.3%
60-90	60.4	1.6%
70-100	10.9	0.3%
90-120	0.2	0%
0-90	3,738.2	100%
90-180	1.5	0%
0-180	3,739.8	100%

LUMENS PER ZONE

Zone	Lumens	% Total	Zone	Lumens	% Total
0-10	116.4	3.1%	90-100	0.2	0
10-20	349.9	9.4%	100-110	0	0
20-30	624.0	16.7%	110-120	0	0
30-40	953.5	25.5%	120-130	0	0
40-50	1,102.0	29.5%	130-140	0.2	0
50-60	532.0	14.2%	140-150	0.5	0
60-70	49.6	1.3%	150-160	0.4	0
70-80	8.5	0.2%	160-170	0.2	0
80-90	2.2	0.1%	170-180	0.1	0

LED/AREA: NEC/CEC EXPLOSIONPROOF

Type V, Clear Glass, 5000K CCT
 REPORT NUMBER: CMLLED15G5BU

POLAR CANDELA DISTRIBUTION

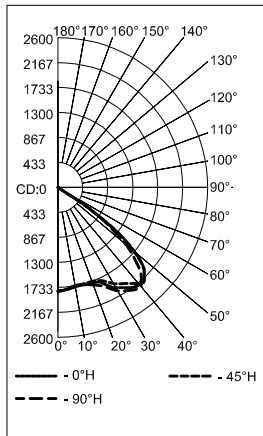

ISOFOOT CANDLE PLOT

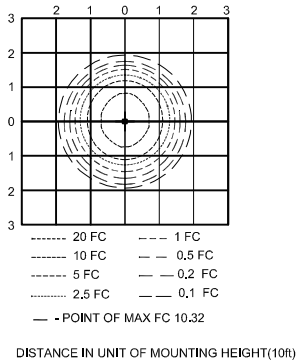

ZONAL LUMEN SUMMARY

Zone	Lumens	% Luminaire
0-30	1,573.4	29.3%
0-40	2,948.7	54.9%
0-60	5,289.7	98.4%
60-90	83.0	1.5%
70-100	14.2	0.3%
90-120	0.3	0%
0-90	5,372.7	100%
90-180	2.2	0%
0-180	5,374.9	100%

LUMENS PER ZONE

Zone	Lumens	% Total	Zone	Lumens	% Total
0-10	167.6	3.1%	90-100	0.3	0
10-20	504.2	9.4%	100-110	0	0
20-30	901.6	16.8%	110-120	0	0
30-40	1,375.2	25.6%	120-130	0.1	0
40-50	1,584.4	29.5%	130-140	0.6	0
50-60	756.7	14.1%	140-150	0.5	0
60-70	69.1	1.3%	150-160	0.4	0
70-80	11.2	0.2%	160-170	0.3	0
80-90	2.7	0.1%	170-180	0.1	0

APPLETON™

① Complete Code•Master LED luminaire consists of fixture unit and a mounting hood. For Group B applications a Group B rated mounting hood must be used.
 ⌘ Use of a fuse voids Marine Outside Type (Salt Water) rating.

Code•Master™ LED Factory Sealed Luminaires

Explosionproof, Dust-Ignitionproof

NEC/CEC:

Class I, Division 1 and 2, Groups B, C, D ①
 Class I, Zone 1, Groups IIA, IIB, IIB + H₂
 Class II, Division 1, Group E, F, G
 Class II, Division 2, Group F, G

NEC/CEC:

Class III
 Simultaneous Exposure
 Type 3R, 4X
 IP66/67

NEC/CEC:

Suitable for Use in Wet Locations
 Marine Outside Type (Salt Water) ⌘
 Approved for use in Paint Spray Booths

Photometric Data — DATA SHOWN IS ABSOLUTE

Type V, Clear Glass, 5000K CCT

REPORT NUMBER: CML17G5BU

POLAR CANDELA DISTRIBUTION

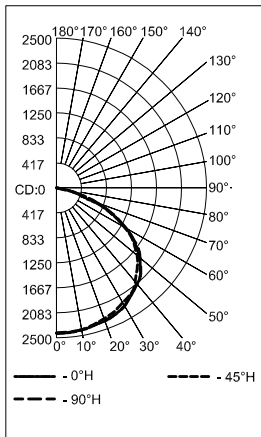

ISOFOOT CANDLE PLOT

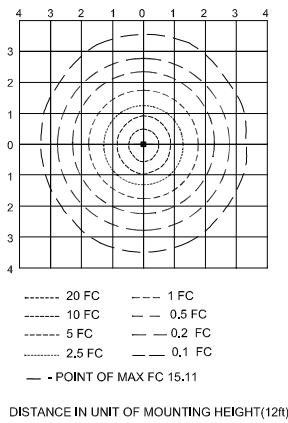

ZONAL LUMEN SUMMARY

Zone	Lumens	% Luminaire
0-30	1,959.3	24.8%
0-40	3,313.1	42%
0-60	6,266.9	79.4%
60-90	1,620.6	20.5%
70-100	560.1	7.1%
90-120	1.0	0%
0-90	7,887.5	100%
90-180	3.2	0%
0-180	7,890.7	100%

LUMENS PER ZONE

Zone	Lumens	% Total	Zone	Lumens	% Total
0-10	116.4	3.1%	90-100	0.2	0
10-20	349.9	9.4%	100-110	0	0
20-30	624.0	16.7%	110-120	0	0
30-40	953.5	25.5%	120-130	0	0
40-50	1,102.0	29.5%	130-140	0.2	0
50-60	532.0	14.2%	140-150	0.5	0
60-70	49.6	1.3%	150-160	0.4	0
70-80	8.5	0.2%	160-170	0.2	0
80-90	2.2	0.1%	170-180	0.1	0

Type V, Clear Glass, 5000K CCT

REPORT NUMBER: CML25G5BU

POLAR CANDELA DISTRIBUTION

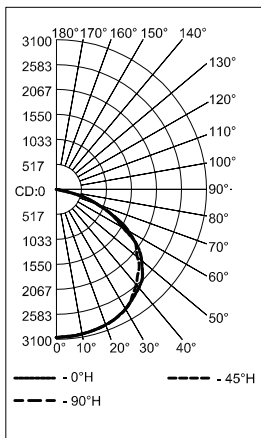

ISOFOOT CANDLE PLOT

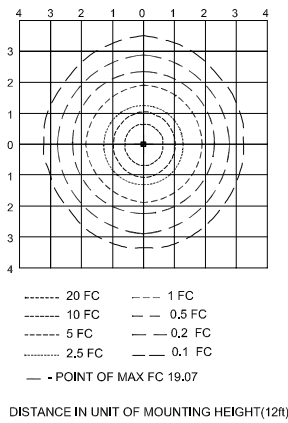

ZONAL LUMEN SUMMARY

Zone	Lumens	% Luminaire
0-30	2,482.0	24.9%
0-40	4,197.1	42.1%
0-60	7,931.9	79.6%
60-90	2,033.5	20.4%
70-100	696.8	7%
90-120	1.3	0%
0-90	9,965.4	100%
90-180	4.0	0%
0-180	9,969.4	100%

LUMENS PER ZONE

Zone	Lumens	% Total	Zone	Lumens	% Total
0-10	289.4	2.9%	90-100	1.2	0
10-20	847.5	8.5%	100-110	0.1	0
20-30	1,345.1	13.5%	110-120	0.0	0
30-40	1,715.1	17.2%	120-130	0.4	0
40-50	1,912.2	19.2%	130-140	0.8	0
50-60	1,822.5	18.3%	140-150	0.6	0
60-70	1,337.9	13.4%	150-160	0.5	0
70-80	632.0	6.3%	160-170	0.3	0
80-90	63.6	0.6%	170-180	0.2	0

① Complete Code•Master LED luminaire consists of fixture unit and a mounting hood. For Group B applications a Group B rated mounting hood must be used.
 ⌘ Use of a fuse voids Marine Outside Type (Salt Water) rating.

LED / AREA: NEC/CEC EXPLOSIONPROOF
APPLETON™

Code•Master™ LED Factory Sealed Luminaires

Explosionproof, Dust-Ignitionproof

NEC/CEC:

Class I, Division 1 and 2, Groups B, C, D ①
 Class I, Zone 1, Groups IIA, IIB, IIB + H₂
 Class II, Division 1, Group E, F, G
 Class II, Division 2, Group F, G

NEC/CEC:

Class III
 Simultaneous Exposure
 Type 3R, 4X
 IP66/67

NEC/CEC:

Suitable for Use in Wet Locations
 Marine Outside Type (Salt Water) Ⓢ
 Approved for use in Paint Spray Booths

Photometric Data – DATA SHOWN IS ABSOLUTE

Type V, Clear Glass, 5000K CCT
 REPORT NUMBER: CMLED35G5BU

POLAR CANDELA DISTRIBUTION

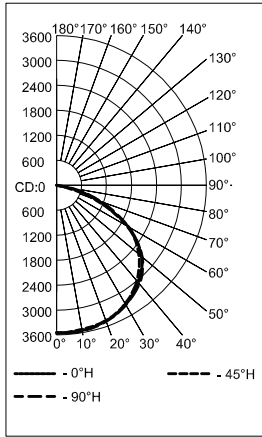

ISOFOOT CANDLE PLOT

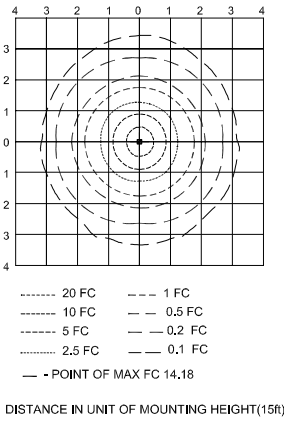

ZONAL LUMEN SUMMARY

Zone	Lumens	% Luminaire
0-30	2,894.8	24.9%
0-40	4,897.1	42.1%
0-60	9,259.1	79.6%
60-90	2,372.4	20.4%
70-100	816.1	7%
90-120	3.4	0%
0-90	11,631.6	99.9%
90-180	7.7	0.1%
0-180	11,639.3	100%

LUMENS PER ZONE

Zone	Lumens	% Total	Zone	Lumens	% Total
0-10	337.3	2.9%	90-100	1.6	0
10-20	988.8	8.5%	100-110	0.8	0
20-30	1,568.7	13.5%	110-120	0.9	0
30-40	2,002.3	17.2%	120-130	0.9	0
40-50	2,232.9	19.2%	130-140	0.8	0
50-60	2,129.2	18.3%	140-150	0.9	0
60-70	1,557.9	13.4%	150-160	0.9	0
70-80	738.7	6.3%	160-170	0.6	0
80-90	75.8	0.7%	170-180	0.2	0

LED/AREA: NEC/CEC EXPLOSIONPROOF

Type V, Clear Glass, 5000K CCT
 REPORT NUMBER: CMLED40G5BU

POLAR CANDELA DISTRIBUTION

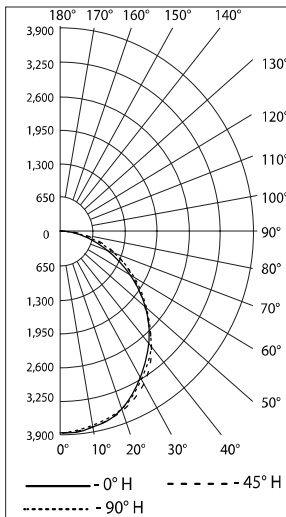

ISOFOOT CANDLE PLOT

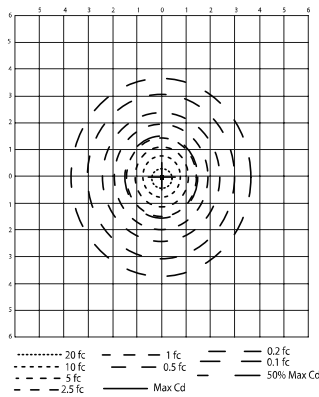

ZONAL LUMEN SUMMARY

Zone	Lumens	% Luminaire
0-30	3,441.9	25.4
0-40	5,808.0	42.8
0-60	10,874.3	80.2
60-90	2,681.4	19.8
70-100	917.3	6.8
90-120	4.0	0
0-90	13,555.6	99.9
90-180	7.2	0.1
0-180	13,562.9	100

LUMENS PER ZONE

Zone	Lumens	% Total	Zone	Lumens	% Total
0-10	402.3	3.0	90-100	2.6	0
10-20	1,179.4	8.7	100-110	0.7	0
20-30	1,860.2	13.7			
30-40	2,366.1	17.4			
40-50	2,609.2	19.2			
50-60	2,457.1	18.1			
60-70	1,766.8	13.0			
70-80	821.2	6.1			
80-90	93.4	0.7			

APPLETON™

① Complete Code•Master LED luminaire consists of fixture unit and a mounting hood. For Group B applications a Group B rated mounting hood must be used.
 * Use of a fuse voids Marine Outside Type (Salt Water) rating.

Code•Master™ LED Factory Sealed Luminaires

Explosionproof, Dust-Ignitionproof

NEC/CEC:

Class I, Division 1 and 2, Groups B, C, D ①
 Class I, Zone 1, Groups IIA, IIB, IIB + H₂
 Class II, Division 1, Group E, F, G
 Class II, Division 2, Group F, G

NEC/CEC:

Class III
 Simultaneous Exposure
 Type 3R, 4X
 IP66/67

NEC/CEC:

Suitable for Use in Wet Locations
 Marine Outside Type (Salt Water) Ⓢ
 Approved for use in Paint Spray Booths

Photometric Data — DATA SHOWN IS ABSOLUTE

Type V, Clear Glass, 5000K CCT

REPORT NUMBER: CMLED75G5BU

POLAR CANDELA DISTRIBUTION

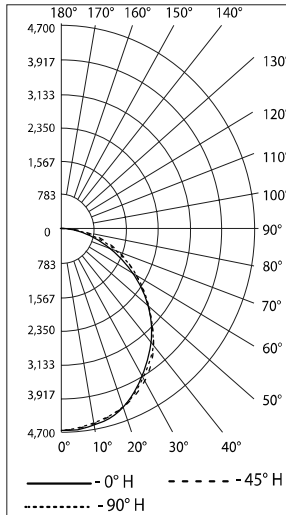

ISOFOOT CANDLE PLOT

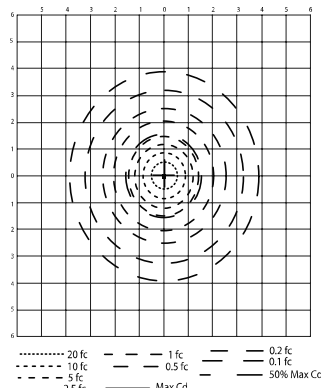

ZONAL LUMEN SUMMARY

Zone	Lumens	% Luminaire
0-30	4,249.2	25.4
0-40	7,168.9	42.9
0-60	13,411.1	80.2
60-90	3,295.9	19.7
70-100	1,127.6	6.7
90-120	4.7	0
0-90	16,707.0	99.9
90-180	8.8	0.1
0-180	16,715.8	100.0

LUMENS PER ZONE

Zone	Lumens	% Total	Zone	Lumens	% Total
0-10	496.7	3.0	90-100	3.2	0
10-20	1,456.1	8.7	100-110	0.8	0
20-30	2,296.4	13.7			
30-40	2,919.7	17.5			
40-50	3,217.1	19.2			
50-60	3,025.1	18.1			
60-70	2,171.4	13.0			
70-80	1,009.8	6.0			
80-90	114.7	0.7			

Type V, Clear Glass, 5000K CCT

REPORT NUMBER: CMLED90G5BU

POLAR CANDELA DISTRIBUTION

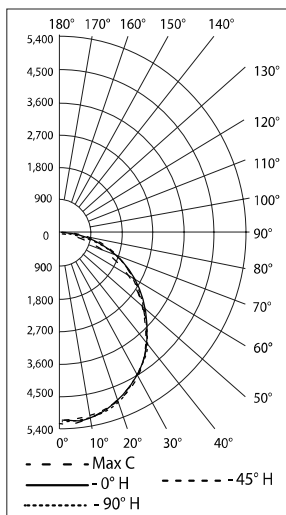

ISOFOOT CANDLE PLOT

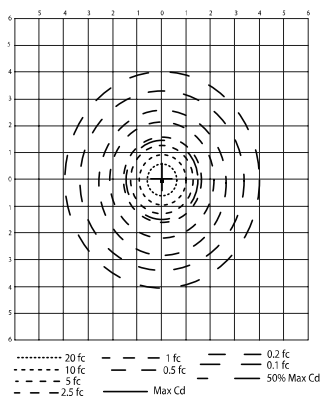

ZONAL LUMEN SUMMARY

Zone	Lumens	% Luminaire
0-30	4,927.2	25.4
0-40	8,295.2	42.9
0-60	15,516.1	80.2
60-90	3,810.1	19.7
70-100	1,302.8	6.7
90-120	5.7	0
0-90	19,326.2	99.9
90-180	10.3	0.1
0-180	19,337.0	100

LUMENS PER ZONE

Zone	Lumens	% Total	Zone	Lumens	% Total
0-10	574.8	3.0	90-100	3.7	0
10-20	1,685.1	8.7	100-110	1.0	0
20-30	2,657.3	13.7			
30-40	3,378.0	17.5			
40-50	3,721.6	19.2			
50-60	3,499.3	18.1			
60-70	2,511.0	13.0			
70-80	1,165.7	6.0			
80-90	133.5	0.7			

① Complete Code•Master LED luminaire consists of fixture unit and a mounting hood. For Group B applications a Group B rated mounting hood must be used.
 * Use of a fuse voids Marine Outside Type (Salt Water) rating.

LED / AREA: NEC/CEC EXPLOSIONPROOF

APPLETON™