



**CITY OF FORT LAUDERDALE  
ENGINEERING DIVISION  
APPLICATION TO INSTALL AT GRADE  
COMMUNICATIONS SERVICE FACILITIES**

PERMIT NO. EAS13-01

*Easement Docs provided first submittal.*

Applicant Name and Job Number AT&T - 1EA40018N  
 Job Address and Location 1707 E Commercial Blvd  
5021 NE 18<sup>th</sup> AVE  
 Description of Work INSTALLING CABINET WITHIN UTILITY EASEMENT

Anticipated start and end dates of work 10/15/13 - 45 DAYS

- This permit application is for an exemption from the requirement to install communications service facilities below grade, in accordance with Section 25-100.1.B.3 of the City of Fort Lauderdale Code of Ordinances (Code). A letter by a qualified expert(s) is attached.
- AT&T is requesting the following waivers (checks all applicable subsections and attach supporting documentation):
  - C.1 (Size)
  - C.2 (Height)
  - C.3 (Front Yard)
  - C.4 (Corner Yard)
  - C.6 (Separation)
  - C.7 (Exist. Facility)
  - C.12 (Collector)

- With the exception of any waivers that may be checked above, the proposed at grade facilities conform to the requirements in Section 25-100.1 of the Code
- Notice of the pending application has been provided to all property owners abutting public rights-of-way within one hundred fifty (150) feet of the proposed site and to the relevant homeowner association, in accordance with Section 25-100.1.E.5 of the Code.
- The proposed site will be maintained by AT&T in accordance with the approved Graffiti Mitigation Plan dated 01/17/2008, which is on file with the City Engineer
- A landscaping maintenance commitment letter from the adjacent property owner and relevant home owner association is attached to this application.
- AT&T shall be responsible for maintaining landscaping
- The proposed at grade facilities depicted on the attached plans are completely located in the public rights-of-way.

As an authorized representative of AT&T, I certify under oath that the forgoing statements are true and correct.

Wayne Palomino

Printed Name of Authorized AT&T Agent

Signature of Authorized AT&T Agent

Sworn to and subscribed before me this 30 day of Sept, 2013

Eva Lewis

Notary Public,  
State of Florida

My Commission Expires July 10, 2015

(Seal)

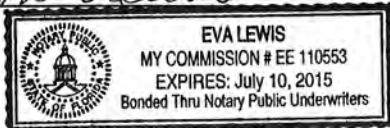

(Do not write below this line)

Conceptual approval date 10/9/13 by [Signature], Subject to the following conditions:

- 1) A detailed visual mitigation plan is required

Final Permit approval date \_\_\_\_\_ by \_\_\_\_\_ Final Inspection date \_\_\_\_\_ by \_\_\_\_\_

\*\*Notify Engineering Permits Division 24 hours prior to starting work at (954) 828-5649



**CITY OF FORT LAUDERDALE  
ENGINEERING DIVISION  
APPLICATION TO INSTALL AT GRADE  
COMMUNICATIONS SERVICE FACILITIES**

PERMIT NO. EAS 10-09

# Original Approval

Applicant Name and Job Number AT&T - PENDING JOB NUMBER

Job Address and Location 5021 NE 18<sup>TH</sup> AVE

Description of Work INSTALLING CABINET WITHIN UTILITY EASEMENT

Anticipated start and end dates of work 10/1/10 - 45 DAYS

- This permit application is for an exemption from the requirement to install communications service facilities below grade, in accordance with Section 25-100.1.B.3 of the City of Fort Lauderdale Code of Ordinances (Code). A letter by a qualified expert(s) is attached. (Pending adoption of Section 47-18.39)
- AT&T is requesting the following waivers (checks all applicable subsections and attach supporting documentation):

- C.1 (Size)
- C.2 (Height)
- C.3 (Front Yard)
- C.4 (Corner Yard)
- C.6 (Separation)
- C.7 (Exist. Facility)
- C.12 (Collector)

- With the exception of any waivers that may be checked above, the proposed at grade facilities conform to the requirements in Section 25-100.1 of the Code
- Notice of the pending application has been provided to all property owners abutting public rights-of-way within one hundred fifty (150) feet of the proposed site and to the relevant homeowner association, in accordance with Section 25-100.1.E.5 of the Code.
- The proposed site will be maintained by AT&T in accordance with the approved Graffiti Mitigation Plan dated 01/17/2008, which is on file with the City Engineer
- A landscaping maintenance commitment letter from the adjacent property owner and relevant home owner association is attached to this application.
- AT&T shall be responsible for maintaining landscaping
- The proposed at grade facilities depicted on the attached plans are completely located in the public rights-of-way.

As an authorized representative of AT&T, I certify under oath that the forgoing statements are true and correct.

Wayne Palomino

Printed Name of Authorized AT&T Agent

Signature of Authorized AT&T Agent

Sworn to and subscribed before me this 15<sup>th</sup> day of JUNE, 2010

Notary Public,  
State of Florida

My Commission Expires July 27, 2014



(Do not write below this line)

Conceptual approval date 11/18/10 by [Signature], Subject to the following conditions:

- 1) A detailed visual mitigation plan is required

Final Permit approval date [Signature] by 11/18/10 Final Inspection date \_\_\_\_\_ by \_\_\_\_\_

\*\*Notify Engineering Permits Division 24 hours prior to starting work at (954) 828-5649

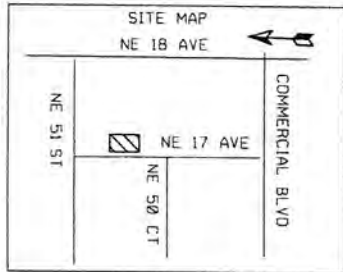

Install at&t cabinet  
within U/E  
1707 E COMMERCIAL BLVD  
Fort Lauderdale

SCALE 1" : 10'

CONSTRUCTION NOT ALLOWED

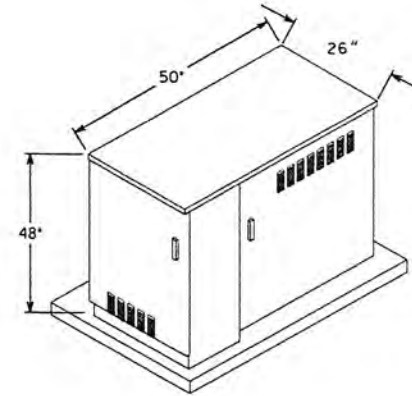

NE 51 ST

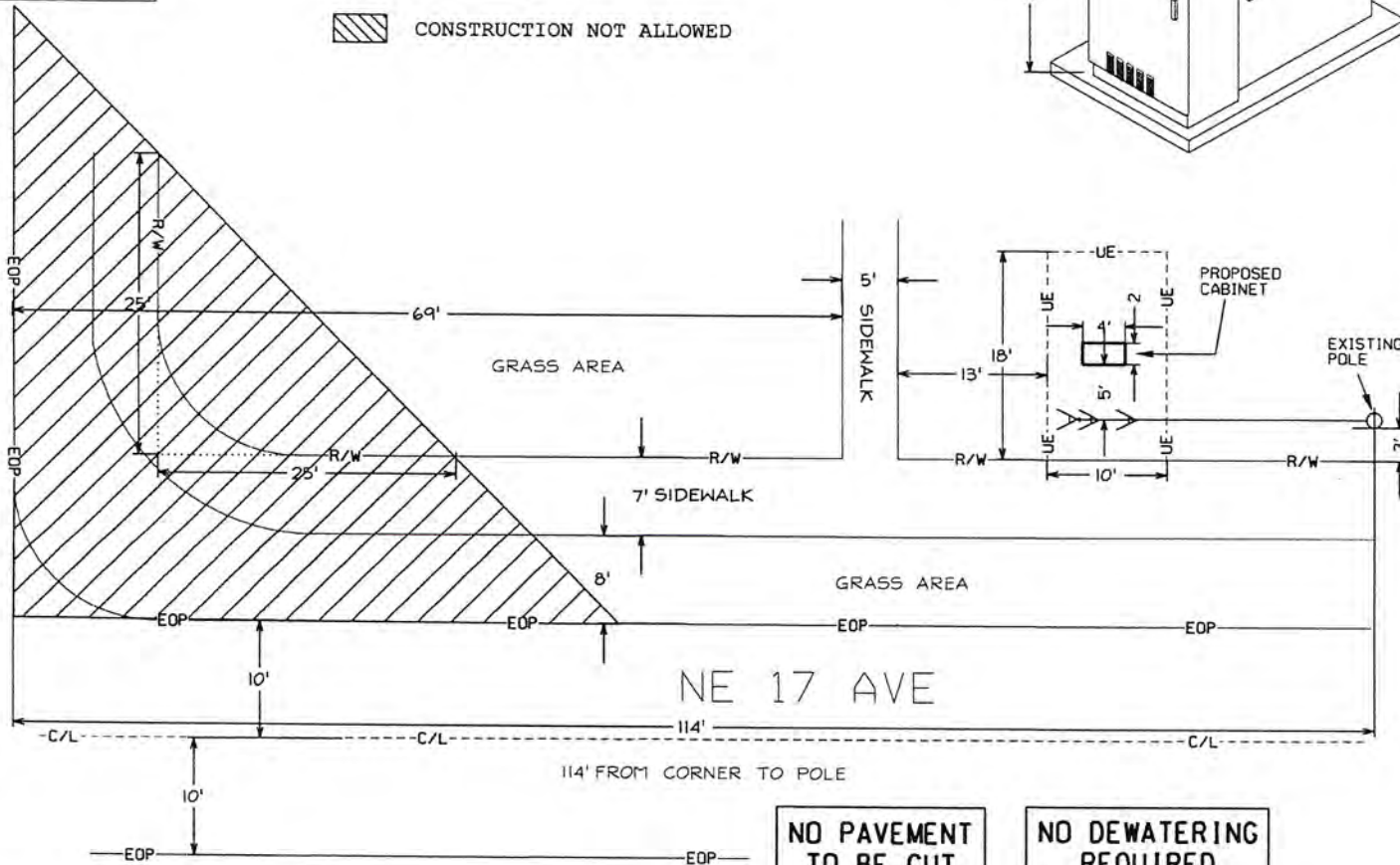

SYMBOL LEGEND		
Proposed	Existing	Description
		AERIAL CABLE
		BURIED CABLE
		BUR JOINT-TRENCH
		BST POLE
		POWER POLE
		ANCHOR & CUT
		PUSH BRACE
		ENCLOSURE
		ENCLOSURE
		MANHOLE
		PIPE/CONDUIT
		CABLE MARKER
		AERIAL SVC WIRE
		BURIED SVC WIRE
		JOINT-TRENCH SVC
		N/A
		N/A
		N/A
		N/A
		N/A
		N/A

**ATTSE**

PROPOSED TELEPHONE FACILITIES  
ON RIGHT OF WAY OF  
FORT LAUDERDALE

1707 E Commercial bl

Exchanges:  
FORT LAUDERDALE

Designer:  
Palomino, Wayne

Phone:  
954-476-2904

Authorization:  
IEA40018N

Dwg. 1 of 2

**NO PAVEMENT  
TO BE CUT**

**NO DEWATERING  
REQUIRED**

LANDSCAPE NOTES:

1. ALL PLANT MATERIAL SHALL CONFORM TO THE STANDARDS FOR FLORIDA No.1 OR BETTER, AS GIVEN IN 'GRADES AND STANDARDS FOR NURSERY PLANTS' PART I, 1963, AND PART II, STATE OF FLORIDA, DEPARTMENT OF AGRICULTURE, TALLAHASSEE, FLORIDA
2. IT SHALL BE THE RESPONSIBILITY OF THE LANDSCAPE CONTRACTOR TO VERIFY LOCATION OF ALL UNDERGROUND UTILITIES PRIOR TO BEGINNING WORK.
3. ALL PLANT BEDS TO RECEIVE 10" OF 50/50 MIX. 50% SAND, 50% MUCK
4. IT SHALL BE THE RESPONSIBILITY OF THE LANDSCAPE CONTRACTOR TO PROVIDE A SMOOTH UNIFORM GRADE PRIOR TO INSTALLING SOD.
5. ALL MULCH TO BE 'FLORAMULCH' MELALEUCA MULCH
6. ALL TREES TO BE STAKED IN THE FIELD WITH APPROVED NURSERY STANDARD METHODS
7. TREES/PALMS SHALL BE INSTALLED A MIN. OF 3' FROM UNDERGROUND UTILITIES.

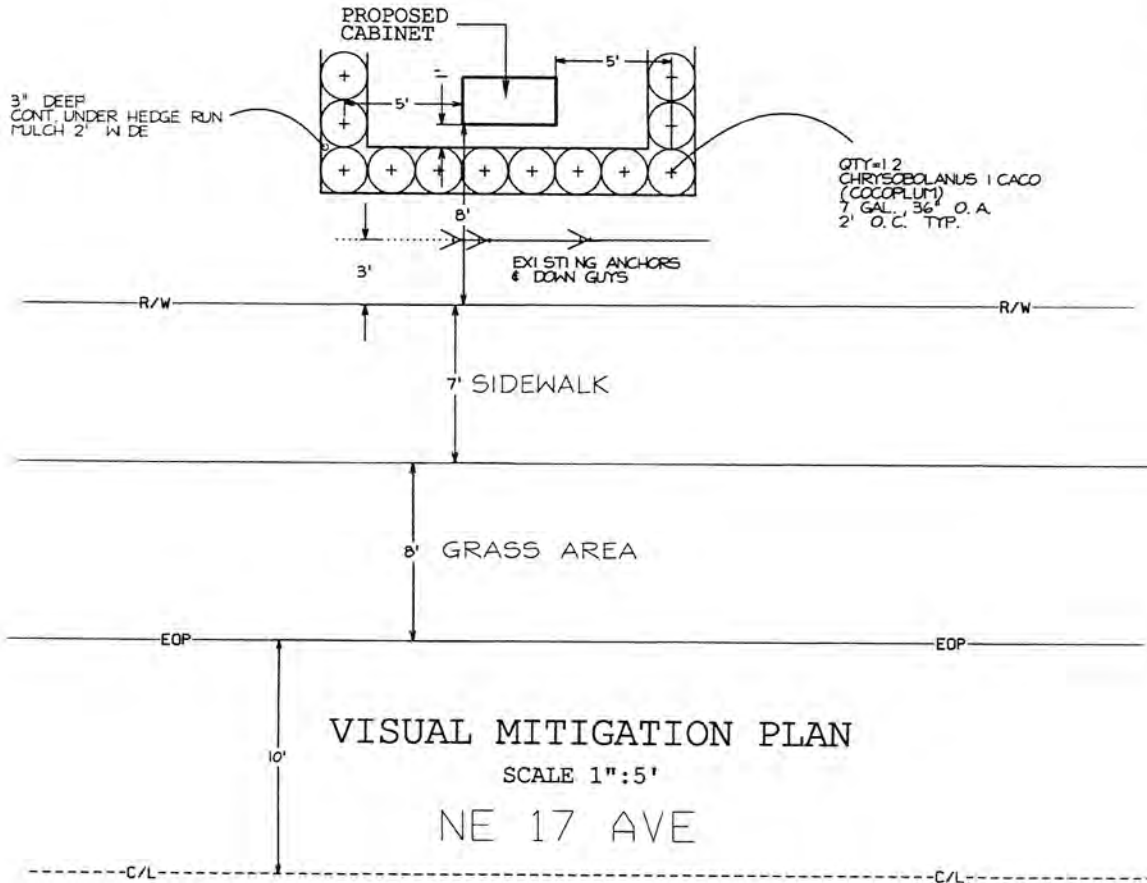

QTY=12  
CHRYSOCELANUS 1 CACO  
(COCOPLUM)  
7 GAL, 36" O. A.  
2' O.C. TYP.

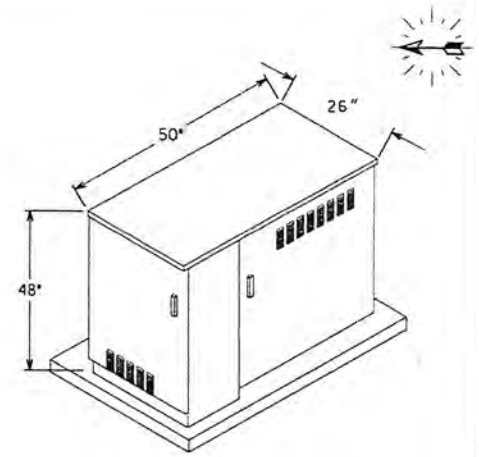

<b>ATTSE</b>	
PROPOSED TELEPHONE FACILITIES ON RIGHT OF WAY OF FORT LAUDERDALE	
1707 E Commercial bl	
Exchange:	FORT LAUDERDALE
Designer:	Palomino, Wayne
Phone:	954-476-2904
Authorization:	IEA40018N
Dwg. <u>  2  </u> of <u>  2  </u>	

Google

To see all the details that are visible on the screen, use the "Print" link next to the map.

*Proposed CABINET*

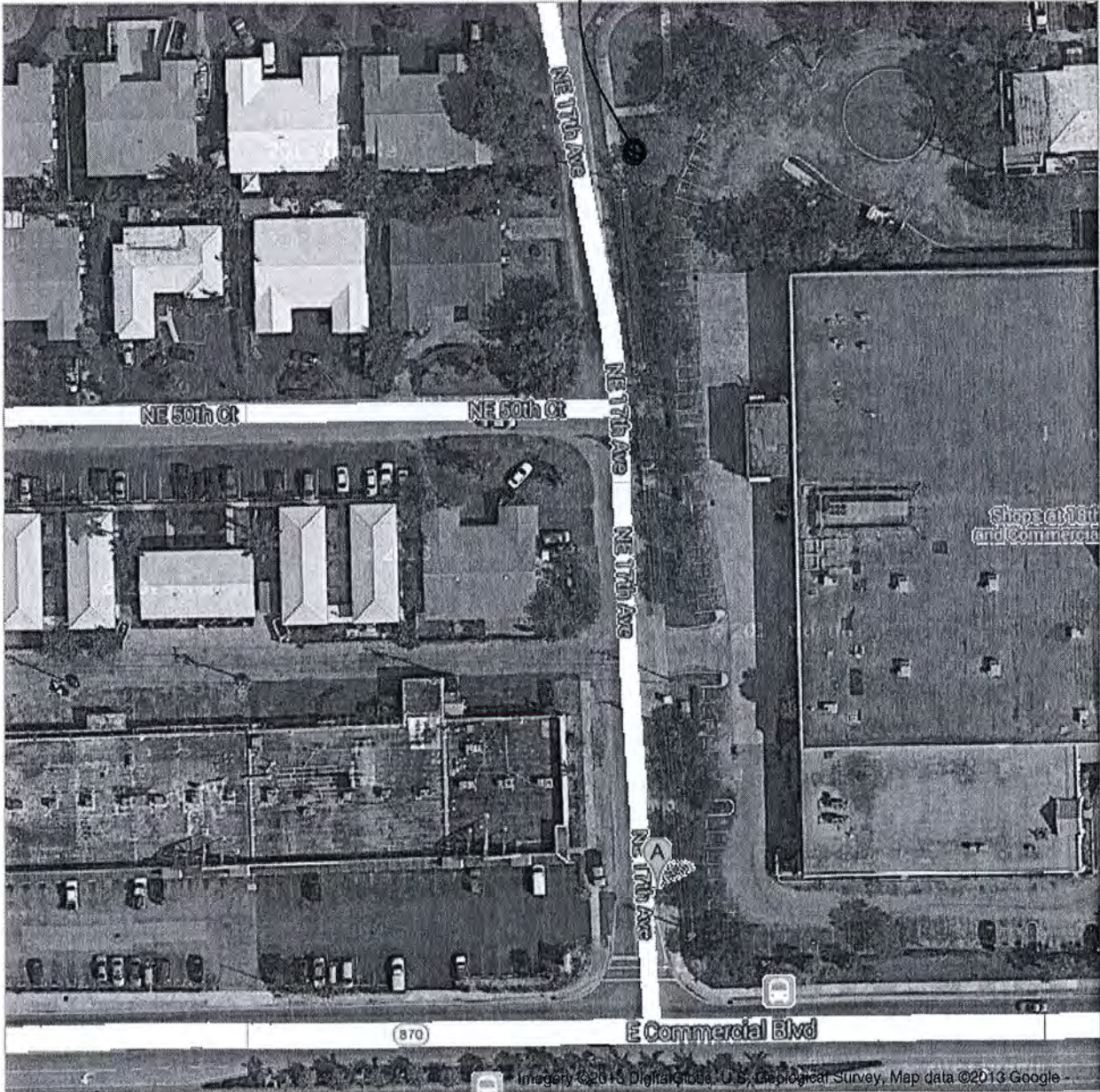









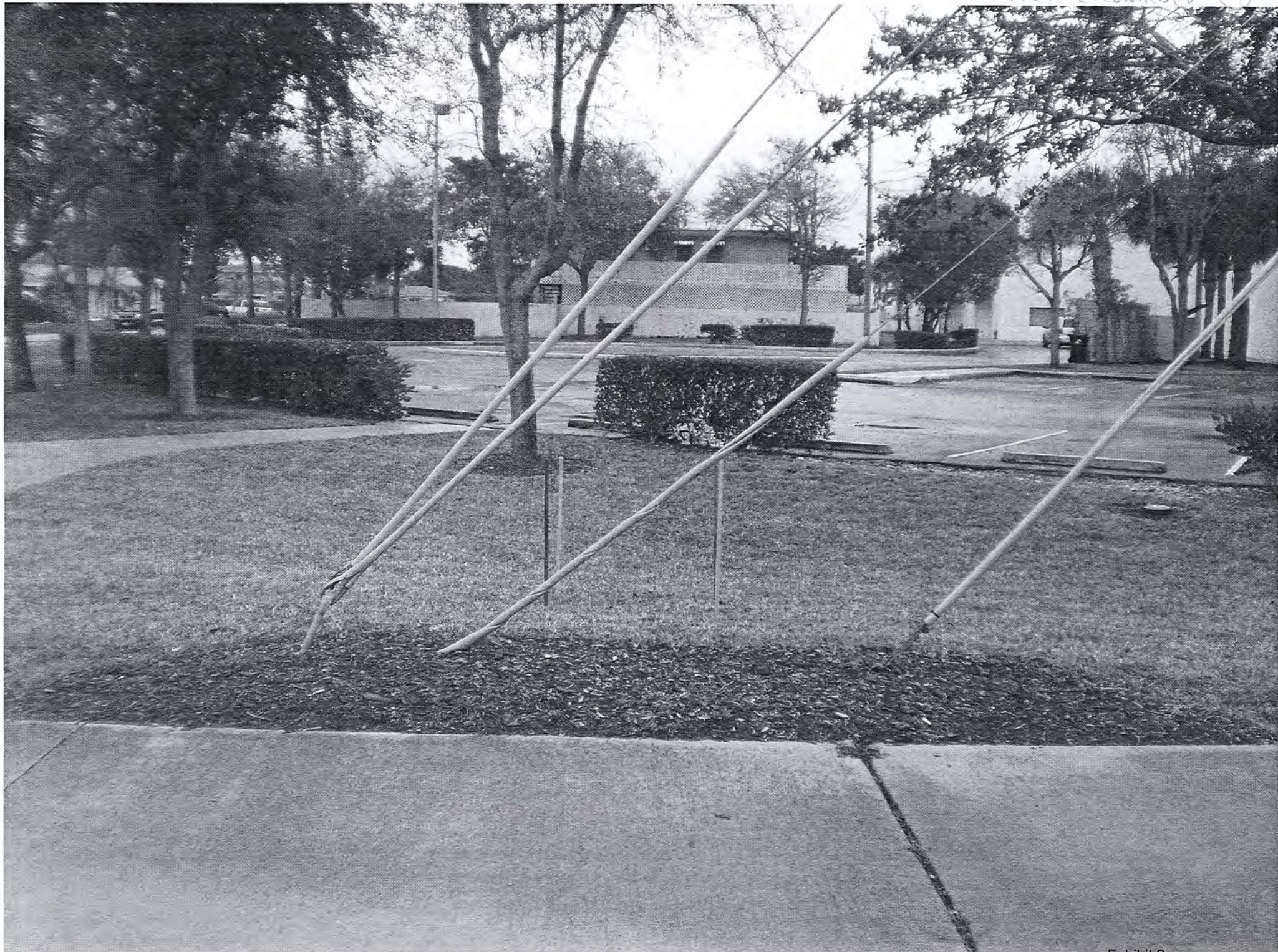

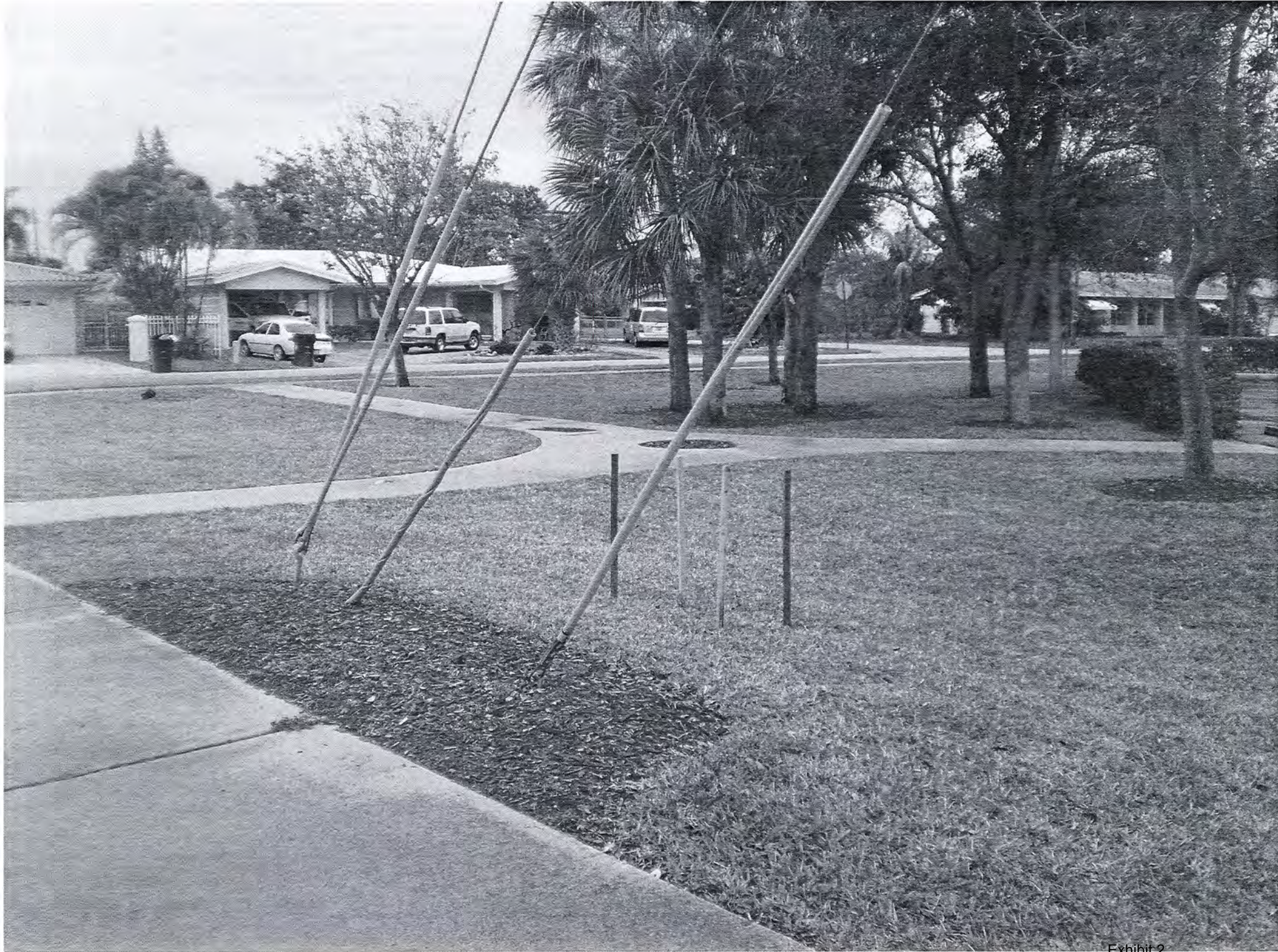



P. L. Doublin  
Director, Analysis/Metrics  
Lightspeed National Field Deployment  
Network Advanced Technologies

AT&T Services, Inc.  
500 McCullough  
Suite 10A40  
San Antonio, TX 78215

T: 210.368.0125  
F: 210.886.4380  
paula.doublin@att.com  
[www.att.com](http://www.att.com)

Oct 1<sup>ST</sup>, 2013

Site Location: **5021 NE 18<sup>th</sup> AVE**

**At&t job No. 1EA4018N**

City Engineer

City of Ft. Lauderdale  
100 N. Andrews Avenue  
Ft. Lauderdale, Florida 33301

Re: Communications Rights-of-Way Ordinance No. C-07-108,  
Application for Exemption from Below Grade Requirement

Dear City Engineer:

In accordance with Section 25-100.B.1 of the above-referenced ordinance ("Ordinance"), BellSouth Telecommunications, Inc. d/b/a AT&T Florida submits this application for an exemption from the below grade requirement. As demonstrated below, an exemption is appropriate, as a hardship would result from the imposition of the requirement.

Placing the communications service facility described in the attached right-of-way permit application ("Facility") below grade is technologically infeasible, a below grade facility is not available in the marketplace and all reasonable alternatives have been exhausted. As required by Section B.3. of the Ordinance, information prepared by qualified experts certifying technological infeasibility and evidence that all reasonable alternatives have been exhausted follows:

- (1) Attached as Attachment 1 is information supporting this exemption application that was prepared and certified by the undersigned expert.
- (2) The November 15, 2007 report prepared by Power Services for the City, already on file with the City and titled: Independent Review of Communications Equipment Options Related to the AT&T Lightspeed Program (the "Power Services Report"), also includes information that supports this exemption application. The Power Services Report confirms that a below grade facility is not currently available in the marketplace, noting that Power Services "found only one vendor with a [Flush to Grade facility] close to potential application for the Lightspeed project. . . ." and adding that additional development, testing and certification would be necessary for its use. *Executive Summary of Power Services Report*, pages 4-5, 7. The Power Services Report also confirms that, for any flush to grade solution, ". . . there will be an above-grade footprint for access, ventilation, and cooling[.]" Accordingly,



P. L. Doublin  
Director, Analysis/Metrics  
Lightspeed National Field Deployment  
Network Advanced Technologies

AT&T Services, Inc.  
500 McCullough  
Suite 10A40  
San Antonio, TX 78215

T: 210.368.0125  
F: 210.886.4380  
paula.doublin@att.com  
[www.att.com](http://www.att.com)

the report concludes not only that an entirely below grade solution does not currently exist but will not exist in the future. *Executive Summary of Power Services Report*, page 6. While AT&T Florida does not agree with all of the information in the Power Services Report (including, without limitation, disagreement with the suggestion that the one "passive" flush to grade product identified in the report could be used for the "active" electronics purpose for which the Facility is necessary), AT&T Florida does agree with the conclusion that no below grade facility is currently available in the marketplace.

Submittal of this application for exemption by AT&T Florida should not be construed as AT&T Florida's agreement with the City's authority to impose the below grade requirement in the Ordinance under applicable law, and AT&T Florida reserves all rights in that regard.

If you have any questions, please contact me.

Sincerely,

Paula Doublin

October 1<sup>st</sup>,2013

**Notice of Right-of-Way Permit Application  
Submitted to City of Ft. Lauderdale**

Masier, Camille Huk  
1611 N.E. 50th CT  
Fort Lauderdale, FL 33334

This letter is to inform you that BellSouth Telecommunications, Inc. d/b/a AT&T Florida has submitted a right-of-way permit application to the City of Ft. Lauderdale for the placement of a communications facility in City rights-of-way adjacent to the following property address: 5021 NE 18<sup>th</sup> Ave.

AT&T Florida is sending this notice to you as provided in City Ordinance No. C-07-108, which requires that notice of right-of-way permit application for the communications facility be provided to certain parties in the vicinity of the right-of-way.

A drawing showing the proposed placement and location is attached. The permit application may be reviewed at the City Engineer's Office located at City Hall at 100 N. Andrews Avenue.

The communications facility will enable AT&T Florida to offer new and enhanced communications services to customers in your neighborhood. AT&T Florida looks forward upgrading its network to meet your communications needs.

If you have any questions, please feel free to contact me at (954) 476-2904.

Sincerely,

Wayne Palomino  
MGR OPS PLNG & DESIGN

Attachment

October 1<sup>st</sup>,2013

**Notice of Right-of-Way Permit Application  
Submitted to City of Ft. Lauderdale**

La Cognata, Jennie & Le Montanti, Angela  
1610 N.E. 51<sup>st</sup> ST  
Fort Lauderdale, FL 33334

This letter is to inform you that BellSouth Telecommunications, Inc. d/b/a AT&T Florida has submitted a right-of-way permit application to the City of Ft. Lauderdale for the placement of a communications facility in City rights-of-way adjacent to the following property address: 5021 NE 18<sup>th</sup> Ave.

AT&T Florida is sending this notice to you as provided in City Ordinance No. C-07-108, which requires that notice of right-of-way permit application for the communications facility be provided to certain parties in the vicinity of the right-of-way.

A drawing showing the proposed placement and location is attached. The permit application may be reviewed at the City Engineer's Office located at City Hall at 100 N. Andrews Avenue.

The communications facility will enable AT&T Florida to offer new and enhanced communications services to customers in your neighborhood. AT&T Florida looks forward upgrading its network to meet your communications needs.

If you have any questions, please feel free to contact me at (954) 476-2904.

Sincerely,

Wayne Palomino  
MGR OPS PLNG & DESIGN

Attachment

October 1<sup>st</sup>,2013

**Notice of Right-of-Way Permit Application  
Submitted to City of Ft. Lauderdale**

Carlini, Lorenzo  
1621 N.E. 51<sup>st</sup> ST  
Fort Lauderdale, FL 33334

This letter is to inform you that BellSouth Telecommunications, Inc. d/b/a AT&T Florida has submitted a right-of-way permit application to the City of Ft. Lauderdale for the placement of a communications facility in City rights-of-way adjacent to the following property address: 5021 NE 18<sup>th</sup> Ave.

AT&T Florida is sending this notice to you as provided in City Ordinance No. C-07-108, which requires that notice of right-of-way permit application for the communications facility be provided to certain parties in the vicinity of the right-of-way.

A drawing showing the proposed placement and location is attached. The permit application may be reviewed at the City Engineer's Office located at City Hall at 100 N. Andrews Avenue.

The communications facility will enable AT&T Florida to offer new and enhanced communications services to customers in your neighborhood. AT&T Florida looks forward upgrading its network to meet your communications needs.

If you have any questions, please feel free to contact me at (954) 476-2904.

Sincerely,

Wayne Palomino  
MGR OPS PLNG & DESIGN

Attachment

October 1<sup>st</sup>,2013

**Notice of Right-of-Way Permit Application  
Submitted to City of Ft. Lauderdale**

Wood, Carla & Daryl  
1621 N.E. 50<sup>th</sup> CT  
Fort Lauderdale, FL 33334

This letter is to inform you that BellSouth Telecommunications, Inc. d/b/a AT&T Florida has submitted a right-of-way permit application to the City of Ft. Lauderdale for the placement of a communications facility in City rights-of-way adjacent to the following property address: 5021 NE 18<sup>th</sup> Ave.

AT&T Florida is sending this notice to you as provided in City Ordinance No. C-07-108, which requires that notice of right-of-way permit application for the communications facility be provided to certain parties in the vicinity of the right-of-way.

A drawing showing the proposed placement and location is attached. The permit application may be reviewed at the City Engineer's Office located at City Hall at 100 N. Andrews Avenue.

The communications facility will enable AT&T Florida to offer new and enhanced communications services to customers in your neighborhood. AT&T Florida looks forward upgrading its network to meet your communications needs.

If you have any questions, please feel free to contact me at (954) 476-2904.

Sincerely,

Wayne Palomino  
**MGR OPS PLNG & DESIGN**

Attachment



October 1<sup>st</sup>,2013

**Notice of Right-of-Way Permit Application  
Submitted to City of Ft. Lauderdale**

69<sup>th</sup> Street Properties LP  
1707 E Commercial Blvd  
Fort Lauderdale, FL 33334

This letter is to inform you that BellSouth Telecommunications, Inc. d/b/a AT&T Florida has submitted a right-of-way permit application to the City of Ft. Lauderdale for the placement of a communications facility in City rights-of-way adjacent to the following property address: 5021 NE 18<sup>th</sup> Ave.

AT&T Florida is sending this notice to you as provided in City Ordinance No. C-07-108, which requires that notice of right-of-way permit application for the communications facility be provided to certain parties in the vicinity of the right-of-way.

A drawing showing the proposed placement and location is attached. The permit application may be reviewed at the City Engineer's Office located at City Hall at 100 N. Andrews Avenue.

The communications facility will enable AT&T Florida to offer new and enhanced communications services to customers in your neighborhood. AT&T Florida looks forward upgrading its network to meet your communications needs.

If you have any questions, please feel free to contact me at (954) 476-2904.

Sincerely,

Wayne Palomino  
MGR OPS PLNG & DESIGN

Attachment

October 1st, 2013

**Notice of Right-of-Way Permit Application  
Submitted to City of Ft. Lauderdale**

Bunney Brenneman, President  
Coral Ridge Isles Association  
PO Box 70403  
Fort Lauderdale, FL 33307

This letter is to inform you that BellSouth Telecommunications, Inc. d/b/a AT&T Florida has submitted a right-of-way permit application to the City of Ft. Lauderdale for the placement of a communications facility in City rights-of-way adjacent to the following property address: 5021 NE 18<sup>th</sup> Ave.

AT&T Florida is sending this notice to you as provided in City Ordinance No. C-07-108, which requires that notice of right-of-way permit application for the communications facility be provided to certain parties in the vicinity of the right-of-way.

A drawing showing the proposed placement and location is attached. The permit application may be reviewed at the City Engineer's Office located at City Hall at 100 N. Andrews Avenue.

The communications facility will enable AT&T Florida to offer new and enhanced communications services to customers in your neighborhood. AT&T Florida looks forward upgrading its network to meet your communications needs.

If you have any questions, please feel free to contact me at (954) 476-2904.

Sincerely,

Wayne Palomino  
**MGR OPS PLNG & DESIGN**

Attachment