

Prepared by and return to:

Jason S. Crush, Esquire
Crush Law, P.A.
888 E Las Olas Blvd.,
Suite 201
Ft. Lauderdale, FL 33301

Folio Number: 5042 11 13 0060

ASSUMPTION OF LIABILITY AND HOLD HARMLESS AGREEMENT

THIS ASSUMPTION OF LIABILITY AND HOLD HARMLESS AGREEMENT (“Assumption Agreement”) is entered into this 6th day of May 2024, by and between:

PAWACQCO HOLDINGS 5, LLC, a Florida **Limited Liability Company**, whose principal address is 600 Sagamore Rd Fort Lauderdale, FL 33301 (“OWNER”)

and

CITY OF FORT LAUDERDALE, a Florida municipality having a principal address at 100 North Andrews Avenue, Fort Lauderdale, Florida 33301 (“CITY” or “City”).

RECITALS

WHEREAS, OWNER is the owner of a parcel of land legally described in **Exhibit “A”** attached hereto and made a part hereof (the “Property”); and

WHEREAS, the Property is located on the East side of State Road 5 also known as US-1 (hereinafter referred to as “US-1”), and within a right-of-way which is under the jurisdiction of the State of Florida Department of Transportation Highway System (“FDOT”); and

WHEREAS, certain landscape and streetscape improvements are proposed to be installed in the right-of-way of US-1 (hereinafter referred to as “Improvements”); and

WHEREAS, the Improvements are proposed to be installed on the East side of the US-1 right-of-way (between Mile Post 10.135 to Mile Post 10.161) (the “Improvement Area”); and

WHEREAS, in order to permit the Improvements to be constructed in the FDOT right-of-way, FDOT requires the City to enter into an agreement entitled “State of Florida Department of Transportation District Four Landscape Maintenance Memorandum of Agreement” (“Agreement”), which is attached hereto and incorporated herein as **Exhibit “B”**; and

WHEREAS, the terms and conditions are set forth in the Agreement and impose responsibility for maintenance of the Improvements; and

WHEREAS, as a condition to executing the Agreement, OWNER shall agree to assume all liability, obligations and responsibility under the Agreement and agree to indemnify and hold harmless the City from any and all liability under the Agreement only for the Improvements; and

WHEREAS, OWNER shall not be obligated to assume any maintenance responsibilities with respect to the City's Improvements; and

NOW, THEREFORE, in consideration of the mutual covenants and conditions contained herein, and other good and valuable considerations, the sufficiency and adequacy of which is hereby acknowledged, OWNER and the City hereby agree as follows:

1. **Recitals.** The foregoing Recitals are true and correct and are incorporated herein.
2. **Terms.** The following terms, as used and referred to herein, shall have the meanings set forth below, unless the context indicates otherwise.

City Manager means CITY's Chief Executive Officer, its City Manager, or his or her designee.

City Engineer means the City Engineer (Urban Design Engineer) for the CITY, or the City Engineer's designee. In the administration of this agreement, as contrasted with matters of policy, all parties may rely upon instructions or determinations made by the City Engineer. For the purposes hereof, the CITY Engineer's designee shall be the Urban Design Engineer.

Day(s). In computing any period of time expressed in day(s) in this Agreement, the day of the act, event, or default from which the designated period of time begins to run shall not be included. The last day of the period so computed shall be included unless it is a Saturday, Sunday, or legal holiday, in which event the period shall run until the end of the next day which is neither a Saturday, Sunday nor legal holiday. When the period of time prescribed or allowed is less than seven (7) days, intermediate Saturdays, Sundays, and legal holidays shall be excluded in the computation.

Effective Date means the effective date of this Assumption Agreement, which shall be the date upon which both (i) this Agreement is executed by the proper corporate officials for OWNER and the CITY and (ii) the Agreement is executed by FDOT and the City.

Person means any individual, firm, partnership (general or limited), corporation, company, association, joint venture, joint stock association, estate, trust, business trust, cooperative, limited liability corporation, limited liability partnership, limited liability company or association, or body politic, including any heir, executor, administrator, trustee, receiver, successor or assignee or other person acting in a similar representative capacity for or on behalf of such Person.

3. Compliance and Default. OWNER agrees to assume any and all liability and responsibility for performance under the Agreement except that OWNER shall not be liable for any improvements and work done by the City or third parties unless OWNER provides written consent to such improvements. OWNER hereby agrees to abide by and comply with each and every term and condition set forth in the Agreement and this Assumption Agreement and failure to so comply shall constitute a default under this Assumption Agreement. Any acts or omissions by OWNER or OWNER's contractors, agents or employees that are not in compliance with the terms and conditions of the Agreement shall constitute a default under this Assumption Agreement. The Agreement is incorporated into this Assumption Agreement as if fully set forth herein.

4. Indemnification and Hold Harmless.

(a) OWNER shall protect, defend, indemnify and hold harmless the CITY, its officers, elected officials, volunteers, employees and agents from and against any and all lawsuits, penalties, damages, settlements, judgments, decrees, costs, charges and other expenses charged or incurred, including reasonable attorney's fees actually incurred, or liabilities of every kind, nature or degree arising out of or in connection with the rights, responsibilities and obligations of OWNER under the Agreement and this Assumption Agreement, conditions contained therein, the location, construction, repair, maintenance use or occupancy by OWNER of the Improvements, or the breach or default by OWNER of any covenant or provision of the Agreement or this Assumption Agreement, except for any occurrence arising out of or resulting from the intentional torts or negligence of the CITY, its officers, elected officials, volunteers, agents and employees. However, this exception shall not be deemed a waiver of the City's sovereign immunity. Without limiting the foregoing, any and all such charges, claims, suits, causes of action relating to personal injury, death, damage to property, defects in construction, rehabilitation or restoration of the Improvements by OWNER or others, including but not limited to costs, charges and other expenses charged or incurred, including reasonable attorney's fees and costs actually incurred or liabilities arising out of or in connection with the rights, responsibilities and obligations of OWNER under the Agreement and this Assumption Agreement, or any actual violation of any applicable and known statute, ordinance, administrative order, rule or regulation or decree of any court by OWNER, is included in the indemnity.

(b) OWNER further agrees that upon delivery of proper and timely notice of violations under the Agreement it shall investigate, handle, respond to, provide defense for, and defend any such claims at its sole expense. The City shall retain the right to select counsel of its own choosing as deemed appropriate. This indemnification shall survive termination, revocation or expiration of the Agreement and this Assumption Agreement and shall cover any acts or omissions occurring during the term of the Agreement and this Assumption Agreement.

5. Insurance. At all times during the term of the Agreement and this Assumption Agreement, OWNER, at its expense, shall keep or cause to be kept in effect the insurance coverages for the Improvements set forth in the Agreement and OWNER shall cause such coverage to be extended to CITY as an additional insured and shall furthermore provide Certificates of Insurance to CITY at least fourteen (14) days prior to the commencement of the Agreement and annually thereafter on the anniversary date of the policies.

6. Removal of Improvements and Restoration of Improvement Area.

(a) Except as may otherwise be expressly provided herein, it is agreed that upon termination of the Agreement, in whole or in part, OWNER shall remove all or any part of the Improvements in accordance with the terms and conditions of the Agreement, and OWNER shall restore the right of way and any impacted public utilities to conditions acceptable to FDOT. Such removal and restoration shall be at OWNER's sole cost and expense. In the event OWNER fails to begin to remove all or any part of the Improvements contemplated herein with thirty (30) days after written demand by FDOT or CITY, the CITY is hereby authorized to remove the Improvements that interfere with the easement rights or the public's use of dedicated rights-of-way and restore the right of way and any public utilities to conditions acceptable to FDOT, and all reasonable costs associated with the removal and restoration thereof shall be fully reimbursed by OWNER.

(b) In the event OWNER fails to remove the Improvements and CITY finds it necessary to remove the Improvements in accordance with the foregoing, then the total expense incurred by the CITY in removing the Improvements and the reasonable administrative costs associated therewith shall be considered a special assessment and lien upon the Property. OWNER consents to and grants the City the right to place a lien on the Property. OWNER shall have sixty (60) days from the date of the statement of the total expenses incurred by the CITY and the administrative costs associated therewith within which to pay or contest to the CITY the full amount due. Failure to timely pay the amount due or serve upon the CITY Manager a written letter contesting the statement of assessed expenses and administrative costs after an adequate review of no less than sixty (60) days will result in the matter being scheduled before the CITY Commission for consideration of and adoption of a Resolution assessing against the Property the expenses and administrative costs associated with the CITY's removal of the Improvements. The Resolution may also impose a special assessment lien against the Property for the expenses and costs so assessed. A Notice of the Special Assessment assessed by the CITY Commission for the unpaid expenses and costs as stated above shall be recorded with the CITY Clerk and in the Public Records of Broward County, Florida. The assessed expenses and costs and the lien provided for herein may be foreclosed in the manner provided by law. Any lien filed pursuant to this Agreement shall be subordinate to any mortgages/construction financing obtained for any portion of the Project, whether the mortgage/construction financing obtained before or after the Claim of Lien is recorded.

7. Event of Default; Remedy. In the event the OWNER fails to perform or violates any of the terms or conditions of the Agreement or this Assumption Agreement or is in breach or default in any term or condition thereof, the City shall notify OWNER of the specific failure or violation of this Assumption Agreement or the Agreement in writing and OWNER shall thereafter have a period of thirty (30) days to cure any such failure or violation to the City's reasonable satisfaction (an "Event of Default"). Upon an Event of Default, the City has the right 1) to take any equitable action to enforce the terms and conditions of the Agreement or this Assumption Agreement, it being stipulated by the parties that since the Agreement and this Assumption Agreement deal with the right to use public easements and rights-of-way of FDOT used for a governmental purpose, a violation or breach of any term or condition of the Agreement or this

Assumption Agreement constitutes an irreparable injury to the public and CITY for which there is no adequate remedy at law or 2) take such curative action that was required to be taken by the OWNER under the Agreement and the cost and expense incurred in CITY's curative actions shall be passed on to and owed by OWNER, in which case OWNER shall be liable for payment to CITY for all reasonable and necessary costs and expenses incurred by CITY in connection with the performance of the action or actions associated with the Improvements. OWNER shall reimburse CITY within thirty (30) days following written demand for payment thereof. Interest shall accrue on the unpaid amount at the rate of twelve percent (12%) per annum simple interest but in no event shall interest exceed the highest amount allowed by Florida law. If a dispute arises as to the need for, or amount due to the CITY for repairs or maintenance undertaken by CITY in accordance with the Agreement or Assumption Agreement, and such dispute is not resolved within thirty days (30) days after the date that CITY makes the written demand for payment, OWNER shall pay to CITY the undisputed amount and shall provide CITY with a bond or other security acceptable to CITY for the disputed amount pending a resolution of the dispute by negotiation or litigation. If OWNER does not make the payments required under this Section within the thirty (30) day period set forth herein, then CITY shall have a right to record a Claim of Lien against the Property, which Lien may be either (a) for the total amount of the fines, including all subsections thereunder, or (b) for all reasonable and necessary costs and expenses of any cure undertaken by CITY in accordance with this Section, the cost of any interim insurance policy as provided herein, and reasonable attorneys' fees and costs associated therewith. The Lien shall be effective upon the recording of a Claim of Lien in the Public Records of Broward County, Florida, which Claim of Lien shall state all amounts due and owing to CITY. The Lien may be foreclosed by CITY in the same manner as provided by law for foreclosure of mortgage liens. The Lien shall continue until payment to CITY of the amounts set forth in the Lien (at which time CITY shall record a satisfaction of such lien). In addition to the Lien, CITY shall have all other rights and remedies granted to it at law or in equity for OWNER's failure to pay the fines owed or reimburse CITY for curative actions taken by CITY. CITY shall have all other rights and remedies granted to it at law or in equity for OWNER's failure to pay the fines owed or reimburse CITY for curative actions taken by CITY. The remedies found within this Section are cumulative. The exercise of one does not preclude the exercise of any other remedy.

8. Emergencies. If an emergency situation arises with respect to the Agreement or the Assumption Agreement where the Improvement Area or any condition thereof presents an imminent threat to the health or safety of Persons or property, the CITY shall make reasonable efforts to provide telephone or email notice to OWNER's Contact Person. If, following that notice, OWNER fails to take timely action to correct the emergency situation, and allowing the emergency situation to continue would pose an imminent threat to health or safety to Persons or property, CITY may undertake such limited actions as are necessary to eliminate the emergency; and CITY shall be entitled to recover its reasonable costs of cure or resolve the emergency from OWNER in accordance with provisions hereof. For the purposes of this Section, OWNER's Contact Person shall be PAWACQCO HOLDINGS 5, LLC, Attention: Mike Hildabrandt; telephone number (954) 650-0572; and e-mail address: mhildabrandt@thelasolascompany.com. In the event the OWNER's Contact Person or any other information pertaining to the OWNER's Contact Person shall change, such change shall be provided to the CITY Engineer and the CITY's Director of the Transportation and Mobility Department, in writing.

9. Damage to Public Property. In the event the use, operation, maintenance, repair, construction, demolition or reconstruction of the Improvements cause(s) any damage whatsoever to any other public property, then OWNER shall be responsible for the cost of repair and shall, at CITY's option, make said repairs, subject to CITY's reasonable satisfaction.

10. Notices.

(a) Except as provided in subparagraph (c) below, whenever it is provided herein that notice, demand, request or other communication shall or may be given to, or served upon, either of the parties by the other, or either of the parties shall desire to give or serve upon the other any notice, demand, request or other communication with respect hereto or with respect to any matter set forth in the Agreement or this Assumption Agreement, each such notice, demand, request or other communication shall be in writing and any law or statute to the contrary notwithstanding shall not be effective for any purpose unless the same shall be given by hand delivery, or by a nationally recognized overnight courier, or by mailing the same by registered or certified mail, postage prepaid, return receipt requested, addressed to the party at the address set forth below, or at such other address or addresses and to such other person or firm as OWNER may from time to time designate by notice as herein provided.

(b) All notices, demands, requests or other communications hereunder shall be deemed to have been given or served for all purposes hereunder upon receipt if by hand delivery, or upon one (1) business day after deposit with such overnight courier as required above, or upon two (2) business days after deposit with the United States mail, postage prepaid, in the manner aforesaid, provided, however, that for any distance in excess of five hundred (500) miles, air mail service or Federal Express or similar carrier shall be utilized, if available.

AS TO CITY: Greg Chavarria
City Manager
City of Fort Lauderdale
100 North Andrews Avenue
Fort Lauderdale, Florida 33301

With copy to: Thomas J. Ansbro
City Attorney
City of Fort Lauderdale
1 East Broward Blvd., Suite 1605
Fort Lauderdale, Florida 33301

With a copy to: Transportation and Mobility Director
City of Fort Lauderdale
290 N.W. 3rd Avenue
Fort Lauderdale, Florida 33301

AS TO OWNER: PAWACQCO HOLDINGS 5, LLC
ATTN: Michael C. Weymouth

600 Sagamore Rd.
Fort Lauderdale, FL 33301

(c) As to activities under Paragraph 8, Emergencies, notice need not be given in accordance with subparagraph (a) above, but notice shall be sufficient if given to the Contact Person pursuant to Paragraph 8, Emergencies.

11. Independent Contractor. As between CITY and OWNER, OWNER is an independent contractor under this Assumption Agreement. In providing such services, neither OWNER nor its agents shall act as officers, employees, or agents of CITY. No partnership, joint venture, or other joint relationship is created hereby. CITY does not extend to OWNER or OWNER's agents any authority of any kind to bind CITY in any respect whatsoever.

12. Joint Preparation. Each party and its counsel have participated fully in the review and revision of this Assumption Agreement and acknowledge that the preparation of this Assumption Agreement has been their joint effort. The language agreed to expresses their mutual intent and the resulting document shall not, solely as a matter of judicial construction, be construed more severely against one of the parties than the other. The language in this Assumption Agreement shall be interpreted as to its fair meaning and not strictly for or against any party.

13. Interpretation of Agreement; Severability. This Assumption Agreement shall be construed in accordance with the laws of the State of Florida. If any provision hereof, or its application to any person or situation, is deemed invalid or unenforceable for any reason and to any extent, the remainder of this Assumption Agreement or the application of the remainder of the provisions, shall not be affected. Rather, this Assumption Agreement is to be enforced to the extent permitted by law. The captions, headings and title of this Assumption Agreement are solely for convenience of reference and are not to affect its interpretation. Each covenant, term, condition, obligation or other provision of this Assumption Agreement is to be construed as a separate and independent covenant of the party who is bound by or who undertakes it, and each is independent of any other provision of this Assumption Agreement, unless otherwise expressly provided. All terms and words used in this Assumption Agreement, regardless of the number or gender in which they are used, are deemed to include any other number and other gender, as the context requires.

14. Successors. This Assumption Agreement shall be binding on and inure to the benefit of the parties, their successors and assigns. It is intended that this Assumption Agreement and the rights and obligations set forth herein shall run with the land and shall bind every person having any fee, leasehold or other interest therein and shall inure to the benefit of the respective parties and their successors, assigns, heirs, and personal representatives.

15. No Waiver of Sovereign Immunity. Nothing contained in this Assumption Agreement is intended to serve as a waiver of sovereign immunity by the City to which sovereign immunity may be applicable.

16. Third Party Beneficiaries. The parties expressly acknowledge that it is not their intent to create or confer any rights or obligations in or upon any third person or entity under this Assumption Agreement. None of the parties intend to directly or substantially benefit a third party by this Agreement. The parties agree that there are no third-party beneficiaries to this Agreement and that no third party shall be entitled to assert a claim against any of the parties based on this Agreement. Nothing herein shall be construed as consent by any agency or political subdivision of the State of Florida to be sued by third parties in any manner arising out of any contract.

17. Non-Discrimination. OWNER shall not discriminate against any Person in the performance of duties, responsibilities and obligations under this Assumption Agreement because of race, age, religion, color, gender, national origin, marital status, disability or sexual orientation.

18. Records. Each party shall maintain its own respective records and documents associated with this Assumption Agreement in accordance with the records retention requirements applicable to public records. Each party shall be responsible for compliance with any public documents request served upon it pursuant to Chapter 119, Florida Statutes as applicable, and any resultant award of attorney's fees for non-compliance with that law.

19. Entire Agreement. This document incorporates and includes all prior negotiations, correspondence, conversations, agreements and understandings applicable to the matters contained herein and the parties agree that there are no commitments, agreements or understandings concerning the subject matter of this Assumption Agreement that are not contained in this document. Accordingly, the parties agree that no deviation from the terms hereof shall be predicated upon any prior representations or agreements, whether oral or written.

20. Waiver. The parties agree that each requirement, duty and obligation set forth herein is substantial and important to the formation of this Assumption Agreement and, therefore, is a material term hereof. Any party's failure to enforce any provision of this Assumption Agreement shall not be deemed a waiver of such provision or modification of this Assumption Agreement. A waiver of any breach of a provision of this Assumption Agreement shall not be deemed a waiver of any subsequent breach and shall not be construed to be a modification of the terms of this Assumption Agreement.

21. Governing Law. This Assumption Agreement shall be interpreted and construed in accordance with and governed by the laws of the State of Florida. Any controversies or legal problems arising out of this Assumption Agreement and any action involving the enforcement or interpretation of any rights hereunder, shall be brought exclusively in the state courts of the Seventeenth Judicial Circuit in Broward County, Florida, and venue for litigation arising out of this Assumption Agreement shall be exclusively in such state courts, forsaking any other jurisdiction which either party may claim by virtue of its residency or other jurisdictional device. **By entering into this Assumption Agreement, CITY and OWNER hereby expressly waive any rights either party may have to a trial by jury of any civil litigation related to the Agreement or this Assumption Agreement or any acts or omissions in relation thereto.**

22. Recording. This Assumption Agreement shall be recorded in the Public Records of Broward County, Florida, the costs of which shall be borne by OWNER. OWNER shall record

this Assumption Agreement with attached exhibits and a copy of the recorded Assumption Agreement shall be provided to City and filed with the City Clerk's Office.

23. Term. This Assumption Agreement shall continue in full force and effect until such time as the Agreement becomes null and void by removal of the Improvements, by operation of law or in accordance with the terms of the Agreement, or is terminated by a court order or mutual agreement between OWNER, FDOT and CITY and no obligations lying thereunder survive such termination.

24. Assignment. OWNER may assign this Assumption Agreement without the prior written consent of the City to a transferee of the fee simple interest in the Property or to an owner responsible for the common areas of the Property (including a condominium association, homeowner's association or property owner's association, with written notice to the City of such assignment and delivery of a copy of the written assumption of responsibilities executed by the assignor and recorded in the Public Records of Broward County, Florida.

25. Police Power. Nothing herein shall be construed as a waiver of the City's police power. OWNER shall comply with the City's codes, ordinances and regulations with respect to installation and construction of the Improvements. OWNER shall construct operate and maintain the Improvements in compliance with all health, sanitary, fire, zoning and building code requirements and any other governing authority with jurisdiction over the Improvement Area and Improvements.

26. No Property Rights. OWNER expressly acknowledges that pursuant to the terms hereof, it gains no property right through this Assumption Agreement or the Agreement to the continued possession or use of the Improvements within the Improvement Area.

(SIGNATURES TO FOLLOW)

IN WITNESS WHEREOF, the undersigned does hereby warrant that they are authorized to enter into this Assumption Agreement by OWNER and the CITY OF FORT LAUDERDALE.

Witnesses:

OWNER:

[Signature]
(Witness #1 Signature)
Jason S. Crugh
(Print Name)

PAWACQCO HOLDINGS 5, LLC, a Florida Limited Liability Company

By: The Las Olas Holding Company, Inc., a Delaware Limited Liability Company
Its Managing Member

[Signature]
(Witness #2 Signature)
Anthony Crush
(Print Name)

By: The Las Olas Company, a Delaware Limited Liability Company
The Surviving entity by Merger

By: [Signature]
Michael C. Weymouth, President

ACKNOWLEDGEMENT

STATE OF Florida)
COUNTY OF Broward)SS

The foregoing instrument was acknowledged before me by means of physical presence or online notarization, this 17 day of April, 2024, by Michael C. Weymouth, as President of The Las Olas Company, a Delaware Limited Liability Company, the surviving entity by merger, with The Las Olas Holding Company, Inc., the managing member of PAWACQCO HOLDINGS 5, LLC, a Florida Limited Liability Company.

(SEAL)

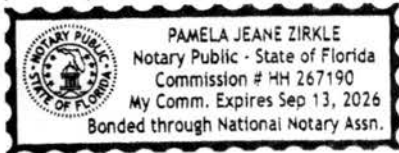

[Signature]
Notary Public, State of Florida
(Signature of Notary taking Acknowledgment)

Pamela J Zirkle
Print, Type of Stamp Commissioned Name
Of Notary Public)

Personally Known X OR Produced Identification _____
Type of Identification Produced _____

AS TO CITY:

IN WITNESS WHEREOF, the parties hereto have executed this Agreement effective the day and year first above written.

AGENCY

ATTEST:

David R. Soloman
David R. Soloman, City Clerk

(SEAL)



CITY OF FORT LAUDERDALE

By: Dean J. Trantalis
Dean J. Trantalis, Mayor

4 day of May, 2024

By: Greg Chavarria
Greg Chavarria, City Manager

29 day of April, 2024

Approved as to form and correctness:
Thomas J. Ansbro, City Attorney

By: Kimberly Cunningham Mosley
Kimberly Cunningham Mosley
Assistant City Attorney

STATE OF FLORIDA:
COUNTY OF BROWARD:

The foregoing instrument was acknowledged before me by means of physical presence or online notarization, this 1st day of MAY, 2024, by **Dean J. Trantalis**, Mayor of the City of Fort Lauderdale, a municipal corporation of Florida. He is personally known to me.

(SEAL)

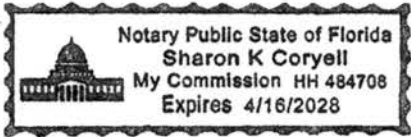

Sharon K Coryell
Notary Public, State of Florida
(Signature of Notary taking Acknowledgment)

SHARON K. CORYELL
Name of Notary Typed,
Printed or Stamped

My Commission Expires: 4/16/2028

STATE OF FLORIDA:
COUNTY OF BROWARD:

The foregoing instrument was acknowledged before me by means of physical presence or online notarization, this 20th day of April, 2024, by **Greg Chavarria**, City Manager of the City of Fort Lauderdale, a municipal corporation of Florida. He is personally known to me.

(SEAL)

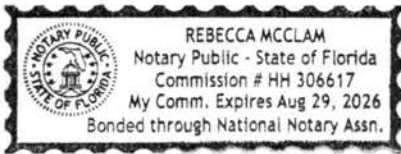

Rebecca McClam
Notary Public, State of Florida
(Signature of Notary taking Acknowledgment)

REBECCA MCCLAM
Name of Notary Typed,
Printed or Stamped

My Commission Expires: 8/29/2026

Exhibit A
Legal Description and Sketch

EXHIBIT "A"

M.D.O.K.

PREPARED BY:
MPG TECHNICAL GROUP CORP.

CERTIFICATE OF AUTH. # LB-6932
1200 NW 78th Avenue, Suite 213, Doral, Florida 33126
Phone: (786) 953-8953

EXHIBIT A - SHEET 1 OF 3

MAINTENANCE AGREEMENT

REFERENCE PROPERTY ADDRESS:
600 SE 2nd Court
Fort Lauderdale, Florida 33301

REFERENCE PARCEL ID:
504211130060 (Broward County Public Records/Property Appraiser's Office)

A portion of SE 6th Avenue lying directly adjacent and to the west of Lots 10 & 11, of Block B, of "EDGEWATER ADD CORR PLAT", according to the Plat thereof, as recorded in Plat Book 2, at Page 73 D, of the Public Records of Dade County, all said lands being in the city of Fort Lauderdale, Broward County, Florida, being more particularly described as follows:

Commence at the Southwest corner of Lot 10, Block B being the Point of Commencement "A" (P.O.C. "A") & Point of Beginning "A" (P.O.B. "A") of the following described perimeter of M.O.T. #1;
thence run N 01° 13' 44" W for a distance of 93.02 feet to a non-tangent curve having a radius of 12.00 feet, the radius point of which bears N 88° 45' 35" E; thence northerly and easterly along said curve an arc distance of 18.85 feet to a point bearing N 01° 14' 25" W from the radius point; thence run N 01° 13' 44" W for a distance of 5.00 feet; thence run N 01° 39' 16" W for a distance of 5.00 feet to a non-tangent curve having a radius of 18.00 feet, the radius point of which bears S 01° 20' 50" E; thence southerly and westerly along said curve an arc distance of 28.24 feet to a point bearing S 88° 46' 16" W from the radius point; thence run S 01° 13' 44" E for a distance of 97.04 feet; thence run N 88° 39' 10" E for a distance of 6.00 feet to the Point of Terminus "A" (P.O.T. "A") of said perimeter.

Containing approximately 711 square feet more or less.

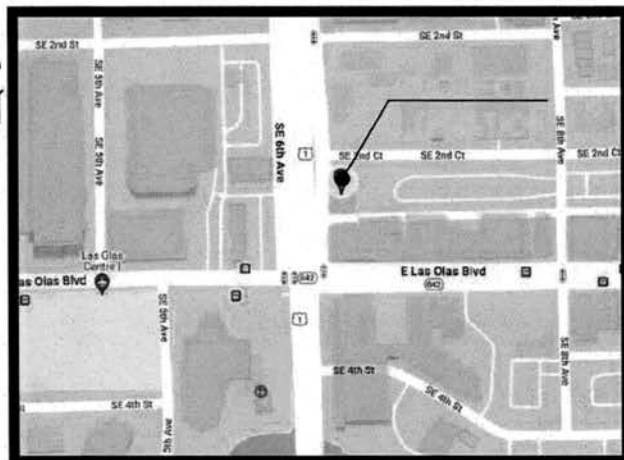

LOCATION MAP
SCALE: N.T.S.
SECTION 11 - TOWNSHIP 50 S - RANGE 42 E
BROWARD COUNTY, FLORIDA



Digitally signed by
Michael Carozza
Date: 2024.04.04
09:47:01 -04'00'

Professional Surveyor & Mapper, # 6965
State of Florida

NOT VALID WITHOUT SHEET 2 & 3 OF 3
(SHEET 1 OF 3 CONTAINS LEGAL DESCRIPTION)

This drawing are not valid unless Signed and embossed with the surveyor's seal or equivalent IGC digital signature

CHECKED BY: M.C.
DRAWN BY: R.D.S.
DATE: 07/17/2023
JOB No.
CAM # 24-035P Sheet 1 of 3 Exhibit 2

EXHIBIT "A" CONTINUED

M D O K.

PREPARED BY:
MPG TECHNICAL GROUP CORP.

CERTIFICATE OF AUTH. # LB-6932
1200 NW 78th Avenue, Suite 213, Doral, Florida 33126
Phone: (786) 953-8953

EXHIBIT A - SHEET 2 OF 3

MAINTENANCE AGREEMENT

REFERENCE PROPERTY ADDRESS:
600 SE 2nd Court
Fort Lauderdale, Florida 33301

REFERENCE PARCEL ID:
504211130060 (Broward County Public Records/Property Appraiser's Office)

SURVEYOR'S NOTES:
All distances as shown are based on the US Survey foot.

This is not a Boundary Survey, but only a graphic depiction of a legal description shown hereon.

All documents are recorded in the Public Records of Broward County, Florida unless otherwise noted.

Bearings are based/referred to an assumed meridian where the Centerline of SE 6th Avenue bears N 01° 13' 44" W.

This survey is intended for the use of the parties to whom this survey is certified to and for. Any reproduction is not an original. This surveyor retains an original to verify these dated contents for validity. Not valid without the signature and raised seal of the Florida Surveyor and Mapper or equivalent IGC digital signature.

This "EXHIBIT A" & "SKETCH TO ACCOMPANY DESCRIPTION" shown hereon are based on information provided by the client.

CERTIFIED TO:
PAWACQCO HOLDINGS 5 LLC

SURVEYOR'S CERTIFICATE:
This is to certify to the herein named firm and/or persons, that in my professional opinion, this "SKETCH TO ACCOMPANY DESCRIPTION" of the herein described proposed maintenance of traffic is true and correct as recently surveyed under my direction. I further certify that this map meets the Minimum Technical Standard Requirements, adopted by the Board of Professional Surveyors and Mappers, pursuant to Chapter 472.027 Florida Statutes, as set forth in Chapter 5J-17, Florida Administrative Code, under Sections 5J-17.051 and 5J-17.052 and is a "SKETCH TO ACCOMPANY DESCRIPTION" as defined in Section 5J-17.050.



Digitally signed by
Michael Carozza
Date: 2024.04.04
09:47:22 -04'00'

Professional Surveyor & Mapper, # 6965
State of Florida

NOT VALID WITHOUT SHEET 1, 3 OF 3
(SHEET 2 OF 3 SURVEYORS NOTES)

This drawing are not valid unless Signed and embossed with the surveyor's seal or equivalent IGC digital signature

CHECKED BY: M.C.
DRAWN BY: R.D.S
DATE: 07/17/2023
JOB No.
CAM # 24-0352 Sheet 2 of 3 Exhibit 2

SKETCH TO ACCOMPANY DESCRIPTION



PREPARED BY:
MPG TECHNICAL GROUP CORP.

CERTIFICATE OF AUTH. # LB-6932
 1200 NW 78th Avenue, Suite 213, Doral, Florida 33126
 Phone: (786) 953-8953

EXHIBIT A - SHEET 3 OF 3

MAINTENANCE AGREEMENT

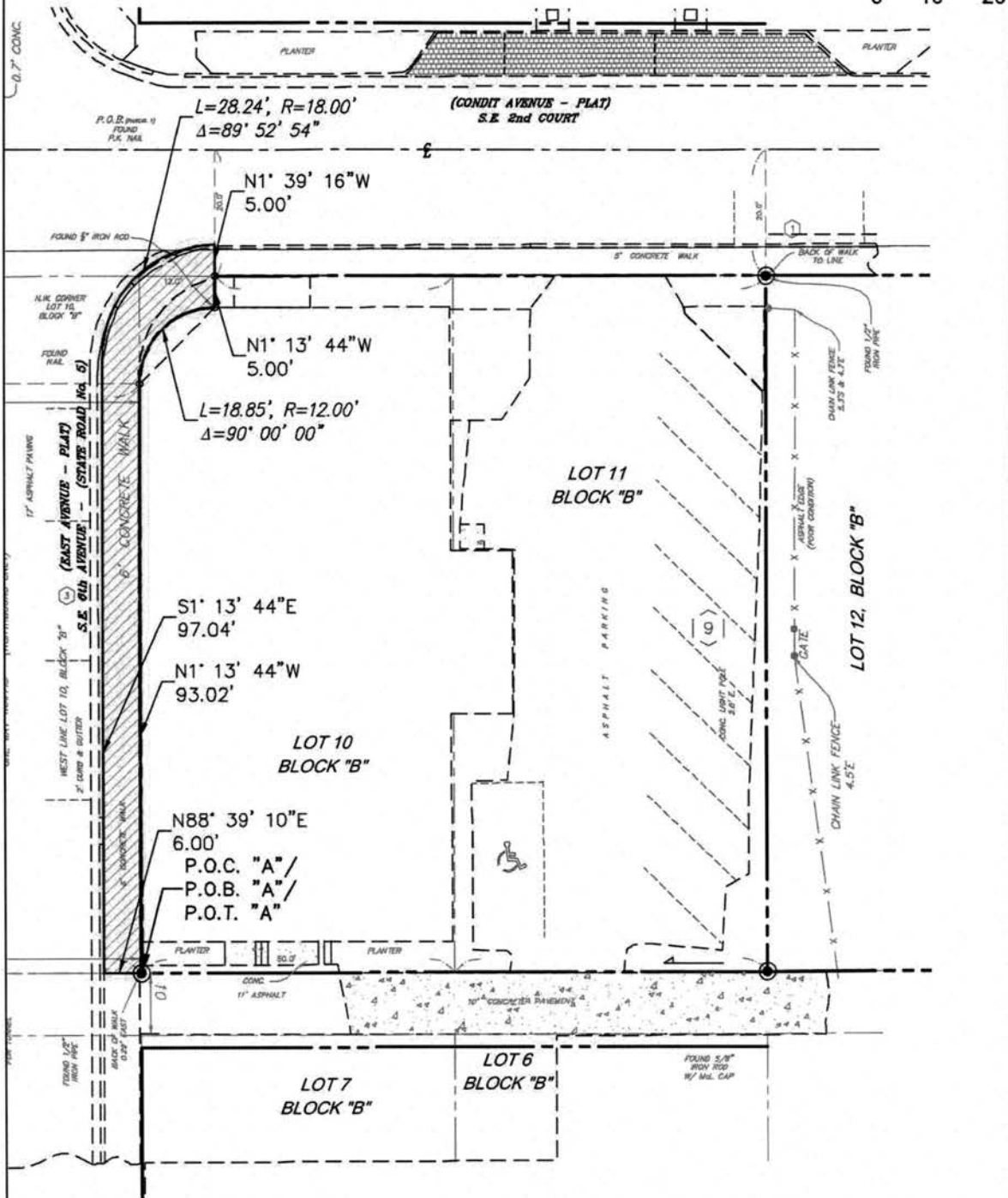

LEGEND

- ⊕ = CENTERLINE
- P.B. = PLAT BOOK
- PG. = PAGE
- R/W. = RIGHT OF WAY
- P.O.B. = POINT OF BEGINNING
- P.O.C. = POINT OF COMMENCE
- P.O.T. = POINT OF TERMINUS

DETAIL

SCALE: 1" = 20'

NOT VALID WITHOUT SHEET 1, 2 OF 3
 (SHEET 3 OF 3 CONTAINS SKETCH DETAIL)

Sheet 3 of 3

Exhibit B

**Florida Department of Transportation District Four Landscape Maintenance
Memorandum of Agreement”**

SECTION: 86010000
PERMIT: 2023-L-491-00005
COUNTY: Broward
STATE RD: 5

**FLORIDA DEPARTMENT OF TRANSPORTATION
DISTRICT FOUR
LANDSCAPE MAINTENANCE MEMORANDUM OF AGREEMENT**

THIS AGREEMENT, made and entered into this ____ day of _____, 20____, by and between the **FLORIDA DEPARTMENT OF TRANSPORTATION**, a component agency of the State of Florida, hereinafter called the **DEPARTMENT**, and the **CITY OF FORT LAUDERDALE**, a municipal corporation, existing under the Laws of Florida, hereinafter called the **AGENCY**.

WITNESSETH:

WHEREAS, the DEPARTMENT has jurisdiction over **State Road 5 (US 1 /Federal Highway)** as part of the State Highway System; and

WHEREAS, as part of the continual updating of the State Highway System, the DEPARTMENT, for the purpose of safety, protection of the investment and other reasons, has constructed and does maintain the highway facility as described in **Exhibit "A"**, within the corporate limits of the AGENCY; and

WHEREAS, the AGENCY seeks to install by permit and maintain certain landscape improvements within the right of way of **State Road 5 (US 1 /Federal Highway)** as described in **Exhibit "B"**; and

WHEREAS, the AGENCY is agreeable to maintaining those landscape improvements within the AGENCY'S limits, including plant materials, irrigation systems and/or hardscape, such as specialty surfacing, site furnishings, or other nonstandard items, if applicable. The AGENCY agrees that such improvements shall be maintained by periodic mowing, fertilizing, weeding, litter pick-up, pruning, necessary replanting, irrigation repair and/or repair/replacement of the specialty surfacing, as needed; and

WHEREAS, it is the intent of the AGENCY and the DEPARTMENT that the AGENCY shall maintain all right of way within the medians, outside the traveled way and improvements made to the traveled way that was made at the request of the AGENCY; and

WHEREAS, the parties hereto mutually recognize the need for entering into an Agreement designating and setting forth the responsibilities of each party; and

WHEREAS, the AGENCY, by Resolution No. _____, dated _____, 20____, attached hereto as **Exhibit "D"** and by this reference made a part hereof, desires to enter into this Agreement and authorizes its officers to do so.

NOW THEREFORE, for and in consideration of the mutual benefits to flow each to the other, the parties covenant and agree as follows:

1. The recitals set forth above are true and correct and are deemed incorporated herein.
2. INSTALLATION OF FACILITIES

The AGENCY shall install and agrees to maintain the *landscape improvements* described herein as: plant materials, irrigation and/or hardscape on the highway facilities substantially as specified in plans and specifications hereinafter referred to as the Project(s) and incorporated herein as **Exhibit "B"**. *Hardscape* shall mean, but not be limited to, any site amenities such as landscape accent lighting, bike racks, fountains, tree grates, decorative free-standing walls, and/or sidewalk, median and/or roadway specialty surfacing such as concrete pavers, stamped colored concrete and/or stamped colored asphalt (also known as patterned pavement).

- (a) All plant materials shall be installed and maintained in strict accordance with sound nursery practice prescribed by the International Society of Arboriculture (ISA). All plant materials installed shall be Florida #1 or better according to the most current edition of Florida Department of Agriculture, *Florida Grades and Standards for Nursery Stock*; and all trees shall meet Florida Power & Light, *Right Tree, Right Place, South Florida*.
- (b) Trees and palms within the right of way shall be installed and pruned to prevent encroachment to roadways, lateral offsets, and sidewalks. Definition of these criteria is included in the most current editions of FDOT standards for design, construction, maintenance, and utility operations on the state highway system and **Exhibit "C"**, the Maintenance Plan.
- (c) Tree and palm pruning shall be supervised by properly trained personnel trained in tree pruning techniques and shall meet the most current standards set forth by the International Society of Arboriculture (ISA) and the American National Standard Institute (ANSI), Part A-300.
- (d) Irrigation installation and maintenance activities shall conform to the standards set forth by the Florida Irrigation Society (FIS) latest edition of FIS, *Standards and Specifications for Turf and Landscape Irrigation Systems*.
- (e) The AGENCY shall provide the FDOT Local Operation Center accurate as-built plans of the irrigation system so if in the future there is a need for the DEPARTMENT to perform work in the area, the system can be accommodated as much as possible. (See paragraph (g) for contact information.)
- (f) If it becomes necessary to provide utilities (water/electricity) to the median or side areas, it shall be the AGENCY'S responsibility to obtain a permit for such work through the local Operations Center (see paragraph (g) below) and the AGENCY shall be responsible for all associated fees for the installation and maintenance of these utilities.

- (g) The AGENCY shall provide the local FDOT Operation Center (Broward Operations, 5548 NW 9th Avenue, Ft. Lauderdale, FL 33309 (954) 776-4300) a twenty-four (24) hour telephone number and the name of a responsible person that the DEPARTMENT may contact. The AGENCY shall notify the local maintenance office forty-eight (48) hours prior to the start of the landscape improvements.
- (h) All specialty surfacing shall be installed and maintained in strict accordance with the most current edition of the *Florida Accessibility Code for Building Construction* and the *Interlocking Concrete Pavement institute (ICPI)*.
- (i) All activities, including landscape improvements installation and future maintenance operations performed on State highway right of way, must be in conformity with the most current edition of the *Manual on Uniform Traffic Control (MUTCD)* and *FDOT Standard Plans for Road Construction, 102-XXX series, Maintenance of Traffic*.
- (j) The most current edition of *FDOT Design Manual, Section 212.11 and Exhibits 212.4 through 212.7 regarding clear sight triangles at intersections* must be adhered to.
- (k) Clear Zone Lateral Offset and as specified in the *FDOT Design Manual, Chapter 215* must be adhered to.
- (l) Landscape improvements shall not obstruct roadside signs or permitted outdoor advertising signs, (see Florida Administrative Code [F.A.C.] Rule Chapter 14-10.)
- (m) If there is a need to restrict the normal flow of traffic, it shall be done on non-holiday, weekday, off-peak hours (9 AM to 3 PM), and the party performing such work shall give notice to the local law enforcement agency within whose jurisdiction such road is located prior to commencing work on the landscape improvements. The DEPARTMENT'S Public Information Officer (see telephone number in paragraph (g) for Operation Center) shall also be notified.
- (n) The AGENCY shall be responsible for ensuring no impacts to utilities will occur within the landscape improvement limits before construction commences.
- (o) The AGENCY shall follow the minimum level of maintenance guidelines as set forth in FDOT'S Rule Chapter 14-40 *Highway Beautification and Landscape Management*, in the *FDOT Guide to Roadside Mowing and Maintenance Management System*, and **Exhibit "C"**, the *Maintenance Plan* for maintenance activities for landscape improvements.

3. MAINTENANCE OF FACILITIES

- A. The AGENCY agrees to maintain the landscape improvements, as existing and those to be installed, within the physical limits described in **Exhibit "A"** and as further described in **Exhibit "B"**. The non-standard improvements within and outside the traveled way shall be maintained by the AGENCY regardless if the said improvement was made by the DEPARTMENT, the AGENCY, or others authorized pursuant to Section 7, by periodic mowing, pruning, fertilizing, weeding, curb and sidewalk edging, litter pickup, necessary replanting, irrigation system repair and/ or repair of any median concrete replacement associated with specialty surfacing (if applicable) following the

DEPARTMENT'S landscape safety and maintenance guidelines, **Exhibit "C"**, the Maintenance Plan. The AGENCY'S responsibility for maintenance shall include all landscaped, turfed and hardscape areas on the sidewalk or within the medians and areas outside the traveled way to the right of way and/or areas within the traveled way containing specialty surfacing. The AGENCY shall be responsible for all maintenance and repairs to FDOT sidewalks directly attributable to tree roots or other AGENCY maintained improvements. It shall be the responsibility of the AGENCY to restore an unacceptable ride condition of the roadway caused by the differential characteristics of non-standard traveled way surfacing (if applicable) on DEPARTMENT right of way within the limits of this Agreement.

- B. Such maintenance to be provided by the AGENCY is specifically set out as follows: to maintain, which means to properly water and fertilize all plant materials; to keep them as free as practicable from disease and harmful insects; to properly mulch the planting beds; to keep the premises free of weeds; to mow the turf to the proper height; to properly prune all plants which at a minimum includes: (1) removing dead or diseased parts of plants, (2) pruning such parts thereof to provide clear visibility to signage, permitted outdoor advertising signs per Florida Statute 479.106 and for those using the roadway and/or sidewalk; (3) preventing any other potential roadway hazards. *Plant materials* shall be those items which would be scientifically classified as plants and including trees, palms, shrubs, groundcover and turf. To maintain also means to remove or replace dead or diseased plant materials in their entirety, or to remove or replace those that fall below original project standards. Palms shall be kept fruit free year-round. To maintain also means to keep the header curbs that contain the specialty surfacing treatment in optimum condition. To maintain also means to keep the nonstandard hardscape areas clean, free from weeds and to repair said hardscape as is necessary to prevent a safety hazard. To maintain also means to keep litter removed from the median and areas outside the travel way to the right of way line. All plants removed for whatever reason shall be replaced by plants of the same species type, size, and grade as specified in the original plans and specifications. Any changes to the original plans shall be submitted by permit application to the DEPARTMENT for review and approval.
- C. If it becomes necessary to provide utilities (water/electricity) to the medians or areas outside the traveled way to maintain these improvements, all costs associated with the utilities associated for the landscape improvements including any impact and/or connection fees, and the on-going cost of utility usage for water and electrical, are the maintaining AGENCY'S responsibility.

The AGENCY shall be directly responsible for impact and connection fees.

- D. The maintenance functions to be performed by the AGENCY may be subject to periodic inspections by the DEPARTMENT at the discretion of the DEPARTMENT. Such inspection findings will be shared with the AGENCY and shall be the basis of all decisions regarding repayment, reworking or agreement termination. The AGENCY shall not change or deviate from said plans without written approval of the DEPARTMENT.

4. DEPARTMENT ACCESS TO FACILITIES

The DEPARTMENT will periodically need access to various features within the limits of this Agreement. Upon request of the DEPARTMENT, the AGENCY will have 14 calendar days to provide access to the items noted by the DEPARTMENT. This may require temporary or permanent removal of improvements such as hardscape, landscape or other items conflicting with the items to which the Department needs access.

Should the AGENCY fail to remove or relocate items as requested, the Department may:

- (a) Remove conflicting improvements or any portion thereof.
- (b) Restore the area with any material meeting Department standards.
- (c) Restore the improvements at the request and funding of the AGENCY.

5. NOTICE OF MAINTENANCE DEFICIENCIES

If at any time after the AGENCY has undertaken the landscape improvements installation and/or maintenance responsibility for the landscape improvements it shall come to the attention of the DEPARTMENT'S District Secretary that the limits, or a part thereof, are not properly maintained pursuant to the terms of this Agreement, said District Secretary, may at his/her option, issue a written notice that a deficiency or deficiencies exist(s), by sending a certified letter to the AGENCY, to place said AGENCY on notice thereof. Thereafter, the AGENCY shall have a period of thirty (30) calendar days in which to correct the cited deficiencies. If said deficiencies are not corrected within this time-period, the DEPARTMENT may, at its option, proceed as follows:

- (a) Maintain the landscape improvements or any part thereof, with the DEPARTMENT or Contractor's personnel and invoice the AGENCY for expenses incurred; and/or
- (b) At the discretion of the DEPARTMENT, terminate the Agreement in accordance with Paragraph 9 of this Agreement and remove, by the DEPARTMENT or Contractor's personnel, all of the landscape improvements installed under this Agreement or any preceding Agreements, except as to trees and palms, and charge the AGENCY the reasonable cost of such removal.

6. FUTURE DEPARTMENT IMPROVEMENTS

It is understood between the parties hereto that the landscape improvements covered by this Agreement may be removed, relocated, or adjusted at any time in the future, as determined to be necessary by the DEPARTMENT, in order that the adjacent state road be widened, altered, or otherwise changed to meet future criteria or planning needs of the DEPARTMENT.

The AGENCY shall be given sixty (60) calendar days' notice to remove said landscape improvements at the AGENCY'S expense after which time the DEPARTMENT may remove same. All permits (including tree permits), fees, and any mitigation associated with the removal, relocation or adjustments of these improvements are the AGENCY'S responsibility.

7. FUTURE AGENCY IMPROVEMENTS

The AGENCY may construct additional landscape improvements within the limits of this Agreement, identified in **Exhibit "A"**, subject to the following conditions:

- (a) Plans for any new landscape improvements shall be subject to approval by the DEPARTMENT. The AGENCY shall not change or deviate from said plans without written approval by the DEPARTMENT.
- (b) All landscape improvements shall be developed and implemented in accordance with appropriate state safety and roadway design standards.
- (c) The AGENCY agrees to comply with the requirements of this Agreement with regard to any additional landscape improvements it chooses to have installed and there will be no cost to the DEPARTMENT.

8. ADJACENT PROPERTY OWNER IMPROVEMENTS

The DEPARTMENT may allow an adjacent property owner to construct additional landscape improvements within the limits of the right of way identified in **Exhibit "A"** that the AGENCY shall be responsible for maintaining under this Agreement, subject to the following conditions:

- (a) Plans for any new landscape improvements shall be subject to approval by the DEPARTMENT and shall require a valid permit attached with a letter of consent to said plans by the AGENCY. The plans shall not be changed or deviated from without written approval by the DEPARTMENT and the AGENCY.
- (b) All landscape improvements shall be developed and implemented in accordance with appropriate state safety and roadway design standards.
- (c) The AGENCY agrees to comply with the requirements of this Agreement with regard to any additional landscape improvements installed by an adjacent owner.

9. AGREEMENT TERMINATION

In addition to those conditions otherwise contained herein, this Agreement may be terminated under any one (1) of the following conditions:

- (a) By the DEPARTMENT, if the AGENCY fails to perform its duties under this Agreement, following ten (10) days written notice.
- (b) By the DEPARTMENT, for refusal by the AGENCY to allow public access to all documents, papers, letters, or other material subject to the provisions of Chapter 119, Florida Statutes, and made or received by the AGENCY in conjunction with this Agreement.

10. AGREEMENT TERM

- (a) The term of this Agreement commences upon execution by all parties and shall remain in effect as long as the improvements shall exist, or until this Agreement is terminated by either party in accordance with Paragraph 9.

- (b) If the DEPARTMENT chooses to cancel the landscape improvements described in **Exhibit "B"**, this Agreement becomes void and the original Agreement is reinstated, if any.

11. LIABILITY AND INSURANCE REQUIREMENTS

- A. With respect to any of the AGENCY'S agents, consultants, sub-consultants, contractors and/or sub-contractors, such party in any contract for the landscape improvements shall agree to indemnify, defend, save and hold harmless the DEPARTMENT from all claims, demands, liabilities, and suits of any nature arising out of, because of or due to any intentional and/or negligent act or occurrence, omission or commission of such agents, consultants, subconsultants, contractors and/or subcontractors. The AGENCY shall provide the DEPARTMENT with written evidence of the foregoing upon the request of the DEPARTMENT. It is specifically understood and agreed that this indemnification clause does not cover or indemnify the DEPARTMENT for its own negligence.
- B. In the event that AGENCY contracts with a third party to provide the services set forth herein, any contract with such third party shall include the following provisions:
 - (1) AGENCY'S contractor shall at all times during the term of this Agreement keep and maintain in full force and effect, at contractor's sole cost and expense, Comprehensive General Liability with minimum limits of \$1,000,000.00 per occurrence combined single limit for Bodily Injury Liability and Property Damage Liability and Worker's Compensation insurance with minimum limits of \$500,000.00 per Liability. Coverage must be afforded on a form no more restrictive than the latest edition of the Comprehensive General Liability and Worker's Compensation policy without restrictive endorsements, as filed by the Insurance Services Office. The AGENCY and DEPARTMENT shall be named as additional insured on such policies.
 - (2) AGENCY'S contractor shall furnish AGENCY with Certificates of Insurance of Endorsements evidencing the insurance coverage specified herein prior to the beginning performance of work under this Agreement.
 - (3) Coverage is not to cease and is to remain in full force and effect (subject to cancellation notice) until all performance required of AGENCY'S contractor is completed. All policies must be endorsed to provide the DEPARTMENT with at least thirty (30) day notice of cancellation and/or restriction. If any of the insurance coverage will expire prior to the completion of work, copies of renewal policies shall be furnished at least (30) days prior to the date of expiration.

12. E-VERIFY REQUIREMENTS

The AGENCY shall:

- (a) Utilize the U.S. Department of Homeland Security's E-Verify system to verify the employment eligibility of all new employees hired by the AGENCY during the term of the contract; and

- (b) Expressly require any subcontractors performing work or providing services pursuant to the state contract to likewise utilize the U.S. Department of Homeland Security's E-Verify system to verify the employment eligibility of all new employees hired by the subcontractor during the contract term.

13. SUPERSEDED AGREEMENTS

This writing embodies the entire Agreement and understanding between the parties hereto and there are no other Agreements and understanding, oral or written, with reference to the subject matter hereof that are not merged herein and superseded hereby.

14. FISCAL TERMS

The DEPARTMENT, during any fiscal year, shall not expend money, incur any liability, or enter into any contract which, by its terms, involves the expenditure of money in excess of the amounts budgeted as available for expenditure during such fiscal year. Any contract, verbal or written, made in violation of this subsection is null and void, and no money will/may be paid on such contract. The DEPARTMENT shall require a statement from the Comptroller of the DEPARTMENT that funds are available prior to entering into any such contract or other binding commitment of funds. Nothing herein contained shall prevent the making of contracts for periods exceeding one (1) year, but any contract so made shall be executory only for the value of the services to be rendered or agreed to be paid for in succeeding fiscal years; and this paragraph shall be incorporated verbatim in all contracts of the DEPARTMENT which are for an amount in excess of TWENTY-FIVE THOUSAND DOLLARS (\$25,000.00) and which have a term for a period of more than one year.

15. DISPUTES

The DEPARTMENT'S District Secretary shall decide all questions, difficulties, and disputes of any nature whatsoever that may arise under or by reason of this Agreement, the prosecution or fulfillment of the service hereunder and the character, quality, amount, and value thereof; and his decision upon all claims, questions, and disputes shall be final and conclusive upon the parties hereto.

16. ASSIGNMENT

This Agreement may not be assigned or transferred by the AGENCY, in whole or in part, without the prior written consent of the DEPARTMENT.

17. LAWS GOVERNING

This Agreement shall be governed by and construed in accordance with the laws of the State of Florida. In the event of a conflict between any portion of the contract and Florida law, the laws of Florida shall prevail. The AGENCY agrees to waive forum and jurisdictional venue. The DEPARTMENT shall determine the forum and venue in which any dispute under this Agreement is decided.

18. NOTICES

Any and all notices given or required under this Agreement shall be in writing and either personally delivered with receipt acknowledgement or sent by certified mail, return receipt requested. All notices shall be sent to the following addresses:

If to the DEPARTMENT:
Florida Dept. of Transportation
3400 West Commercial Blvd.
Ft. Lauderdale, FL 33309-3421
Attn: D4 Landscape Manager

If to the AGENCY:
City of Fort Lauderdale
100 N. Andrews Avenue
Fort Lauderdale, FL 33301
Attn: City Manager

19. LIST OF EXHIBITS

- Exhibit A: Landscape Improvements Maintenance Boundaries
- Exhibit B: Landscape Improvement Plans
- Exhibit C: Maintenance Plan for Landscape Improvements
- Exhibit D: Resolution

In Witness whereof, the parties hereto have executed with this Amendment effective the ____ day _____ year written and approved.

CITY OF FORT LAUDERDALE,
through its CITY COMMISSIONERS

By: 
Dean J. Trantalis, Mayor

6 day of May, 2024

Greg Chevarria, City Manager

Approved as to form:
Thomas J. Ansbro, City Attorney

Kimberly Cunningham Mosley
Assistant City Attorney

ATTEST:

David R. Soloman, City Clerk

(SEAL)

STATE OF FLORIDA
DEPARTMENT OF TRANSPORTATION

By: _____

Transportation Development Director

____ day of _____, 2024

Attest: _____
Executive Secretary

(SEAL)

Legal Review

Office of the General Counsel Date

SECTION: 86010000
PERMIT: 2023-L-491-00005
COUNTY: Broward
STATE RD: 5

EXHIBIT A

LANDSCAPE IMPROVEMENTS MAINTENANCE BOUNDARIES

I. LIMITS OF MAINTENANCE FOR LANDSCAPE IMPROVEMENTS:

State Road 5 (US Highway 1 /Federal Highway) from M.P. 10.135 to M.P. 10.161

II. LANDSCAPE IMPROVEMENTS MAINTENANCE BOUNDARIES:

See attached map

LANDSCAPE IMPROVMENTS MAINTENANCE BOUNDARY MAP

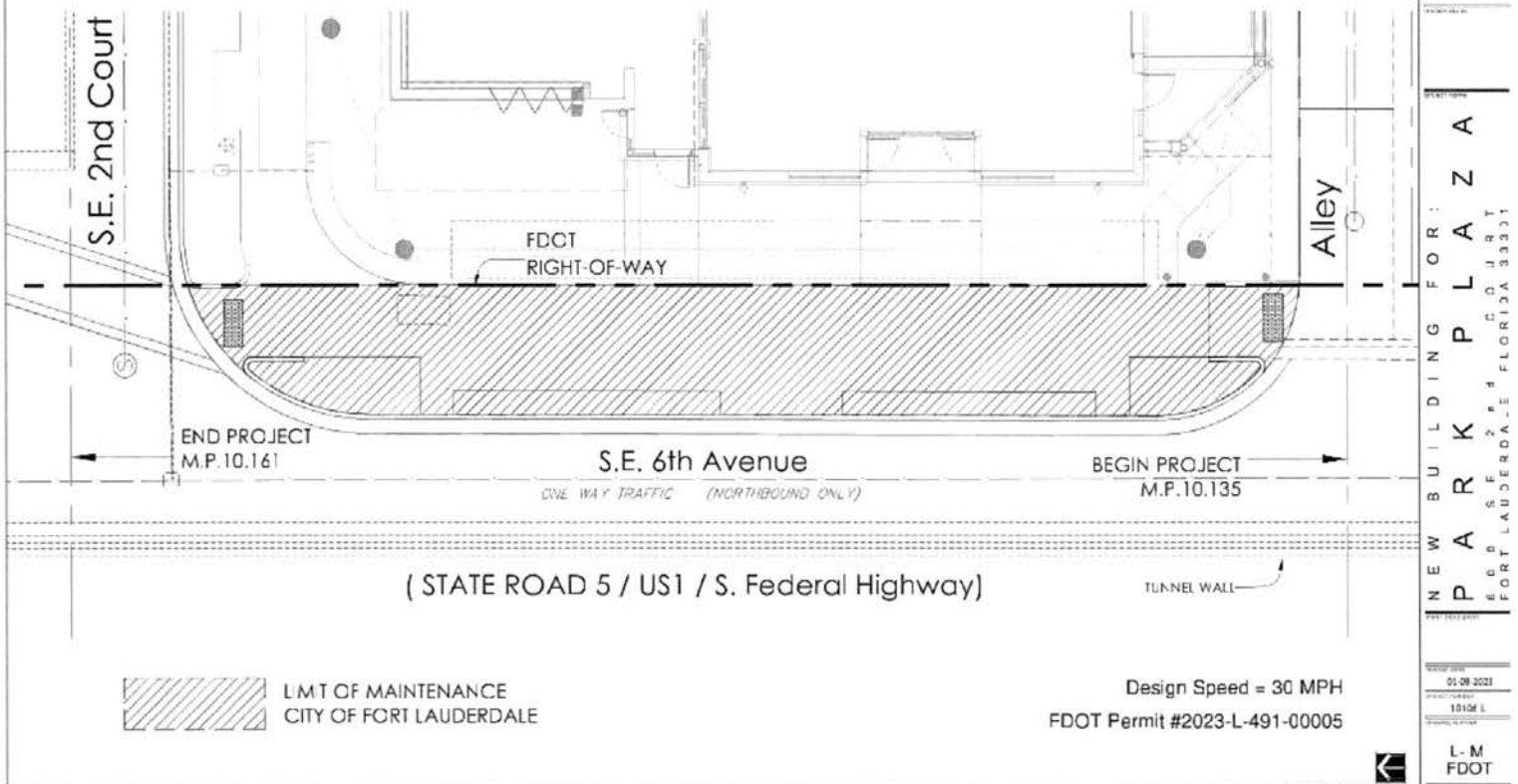

NEW BUILDING FOR:
PARK PLAZA
 100 S.E. 2ND COURT
 FORT LAUDERDALE, FLORIDA 33301

DATE: 01-09-2023
 10:06 L
 L-M
 FDOT

Design Speed = 30 MPH
 FDOT Permit #2023-L-491-00005

SECTION: 86010000
PERMIT: 2023-L-491-00005
COUNTY: Broward
STATE RD: 5

EXHIBIT B

LANDSCAPE IMPROVEMENT PLANS

The AGENCY agrees to install the landscape improvements in accordance with the plans and specifications attached hereto and incorporated herein.

Please see attached plans prepared by: William Eager, RLA
EGS2 Landscape Architecture

Date: January 23, 2024

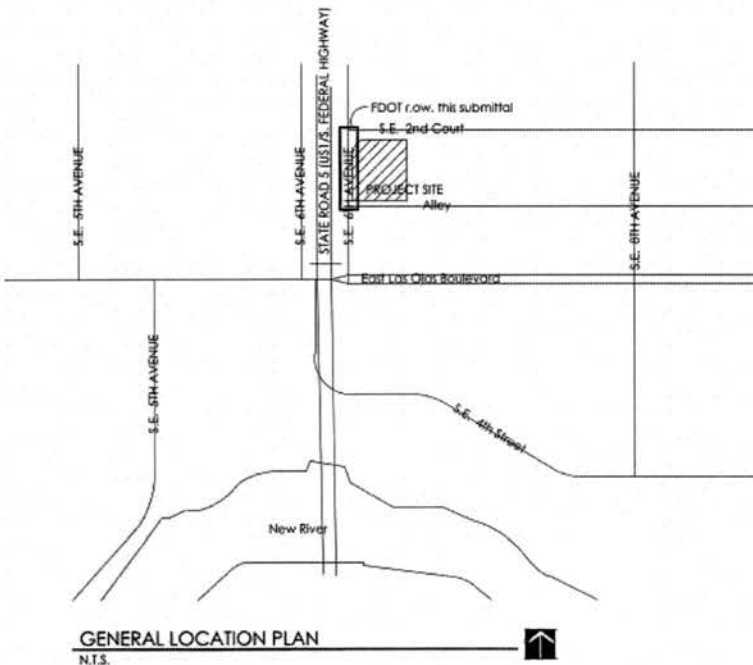

GENERAL LOCATION PLAN
N.T.S.

FDOT GENERAL NOTES

- GOVERNING STANDARD PLANS:**
Florida Department of Transportation, [FY 2023-24] Standard Plans for Road and Bridge Construction and applicable Interim Revisions (IRs) are available at the following website:
<https://www.fdot.gov/design/standardplans>
- GOVERNING STANDARD SPECIFICATIONS:**
Florida Department of Transportation, [FY 2023-24] Standard Specifications for Road and Bridge Construction at the following website:
<https://www.fdot.gov/programmanagement/implemented/specbooks>
- Contractor shall repair all damage done to FDOT property during demolition, relocation &/or installation at his sole discretion.
- Any plant material substitution within or impacting the FDOT Right of Way whether requested by the Contractor, Owner, Landscape Architect or other will need to get approval from the FDOT District Landscape Architect.



LANDSCAPE SHEET INDEX

- L-0.0 FDOT landscape cover sheet 1" = 20'-0"
- L-1.0 FDOT hardscape plan 1" = 20'-0"
- L-3.0 FDOT planting plan & specifications 1" = 20'-0"

IRRIGATION SHEET INDEX

- IR-1.0 FDOT irrigation legend 1" = 20'-0"
- IR-2.0 FDOT irrigation plan
- IR-3.0 FDOT irrigation details
- IR-4.0 FDOT irrigation details
- IR-5.0 FDOT irrigation details
- IR-6.0 FDOT irrigation details
- IR-7.0 FDOT irrigation details
- IR-8.0 FDOT irrigation details
- IR-9.0 FDOT irrigation details
- IR-10.0 FDOT irrigation details
- IR-11.0 FDOT irrigation notes
- IR-12.0 FDOT irrigation notes
- IR-13.0 FDOT irrigation notes



William A Eager

Professional Engineer
Professional Landscape Architect
Professional Surveyor
Professional Geomatics Engineer
Professional Geotechnical Engineer
Professional Civil Engineer
Professional Mechanical Engineer
Professional Electrical Engineer
Professional Environmental Engineer
Professional Fire Protection Engineer
Professional Industrial Engineer
Professional Information Systems Engineer
Professional Nuclear Engineer
Professional Petroleum Engineer
Professional Chemical Engineer
Professional Mining Engineer
Professional Metallurgical Engineer
Professional Ceramic Engineer
Professional Glass Engineer
Professional Polymer Engineer
Professional Textile Engineer
Professional Leather Goods Engineer
Professional Paper Products Engineer
Professional Printing Processes Engineer
Professional Food Processing Engineer
Professional Textile Milling Engineer
Professional Apparel Manufacturing Engineer
Professional Footwear Manufacturing Engineer
Professional Toy Manufacturing Engineer
Professional Sporting Goods Manufacturing Engineer
Professional Furniture Manufacturing Engineer
Professional Wood Products Manufacturing Engineer
Professional Plastics Manufacturing Engineer
Professional Rubber Manufacturing Engineer
Professional Glass Manufacturing Engineer
Professional Ceramics Manufacturing Engineer
Professional Composites Manufacturing Engineer
Professional Metal Fabrication Engineer
Professional Welding Engineer
Professional Casting Engineer
Professional Forging Engineer
Professional Machining Engineer
Professional Tool and Die Engineering
Professional Manufacturing Engineering
Professional Production Engineering
Professional Quality Engineering
Professional Maintenance Engineering
Professional Safety Engineering
Professional Occupational Health and Safety Engineering
Professional Environmental Engineering
Professional Environmental Remediation Engineering
Professional Environmental Restoration Engineering
Professional Environmental Monitoring Engineering
Professional Environmental Assessment Engineering
Professional Environmental Impact Statement Engineering
Professional Environmental Policy Engineering
Professional Environmental Law Engineering
Professional Environmental Economics Engineering
Professional Environmental Planning Engineering
Professional Environmental Management Engineering
Professional Environmental Education Engineering
Professional Environmental Communication Engineering
Professional Environmental Advocacy Engineering
Professional Environmental Policy Analysis Engineering
Professional Environmental Policy Development Engineering
Professional Environmental Policy Implementation Engineering
Professional Environmental Policy Evaluation Engineering
Professional Environmental Policy Research Engineering
Professional Environmental Policy Analysis and Planning Engineering
Professional Environmental Policy Development and Implementation Engineering
Professional Environmental Policy Evaluation and Research Engineering
Professional Environmental Policy Analysis, Development, Implementation, and Evaluation Engineering
Professional Environmental Policy Analysis, Development, Implementation, Evaluation, and Research Engineering

NEW BUILDING FOR:
PARK PLAZA
 600 S.E. 2ND COURT
 FORT LAUDERDALE, FLORIDA 33301

PROJECT NO: 01-29-2023
 SHEET NO: 10106 L
 DATE: 01-29-2023
L-0.0 FDOT



ARCHITECTURAL ALLIANCE
 1111 S. FEDERAL HIGHWAY
 SUITE 100
 LAUDERDALE, FL 33301
 (954) 344-1111
 www.aalliance.com

William A Eager
 ARCHITECT
 1111 S. FEDERAL HIGHWAY
 SUITE 100
 LAUDERDALE, FL 33301
 (954) 344-1111
 www.aalliance.com

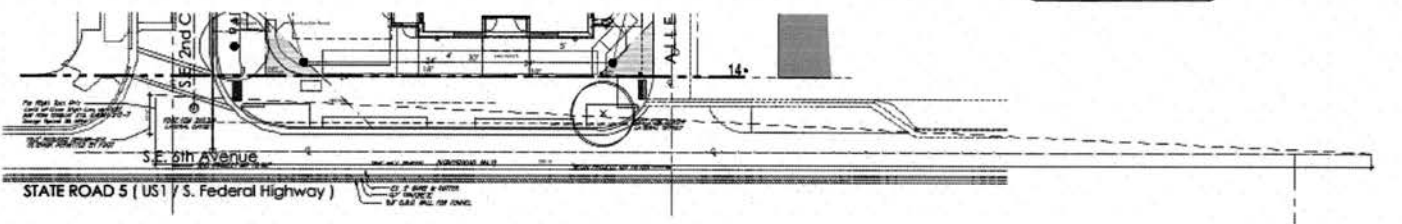

SIGHT TRIANGLE COMPLETE PLAN
 SCALE: 1" = 40'-0"

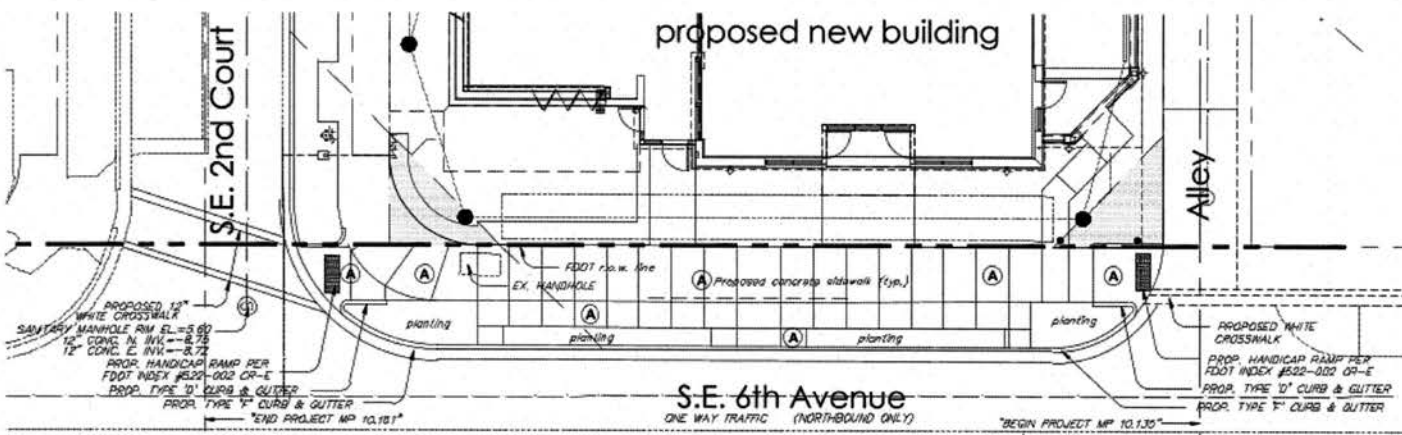

STATE ROAD 5 (US1 / S. Federal Highway)

NOTE: Sheet L-2.0 has been deleted from the set. Information contained on that sheet referenced existing trees on-site. There are no existing trees within the FDOT right of way.

HARDSCAPE PLAN
 SCALE: 1" = 20'-0"

NEW BUILDING FOR:
PARK PLAZA
 600 S.E. 2ND COURT
 FORT LAUDERDALE, FLORIDA 33301

SHEET NO.:
 10106 L
 DRAWING NUMBER:
L-1.0
 FDOT

PLANT LIST - FDOT R.O.W.

- Landscape Contractor shall be familiar w/ all work required by these drawings.
- All plant material furnished by the Landscape Contractor unless otherwise specified in Grades and Standards for Nursery Plants, current edition, by the Florida Department of Agriculture and Consumer Services Division of the Plant Industry, shall be Florida Grade #1 or better.
- All shrubs and groundcovers shall be guaranteed for 1 year from date of final acceptance. All trees and palms shall be guaranteed for 1 year from date of final acceptance. Soil shall be guaranteed for 90 days from final acceptance.
- Planting soil shall be weed free and consist of 80% clean silica sand, 20% organics, mulch and 10% Comstock peat. All plants, including those on the ground level, shall be installed with planting soil as indicated on details.
- Landscape Contractor shall take all steps required to make all planting beds weed and grass free prior to planting.
- Landscape Contractor shall locate and verify all underground utilities prior to digging.
- All trees shall be staked and/or girded in a good workmanlike manner as per attached details. No nail staking permitted.
- All trees shall be fertilized at installation w/ "Aglitron Plus", 21 gram size, w/ a 20-10-5 formulation, (or approved equal) according to manufacturers recommendations.
- All other plants shall be fertilized at installation w/ "Controlax" (one release pellets (or approved equal)) according to manufacturers recommendations.
- Where quantities and/or species differ between the planting plans and plant lists, the plans shall take precedence.
- Landscape Contractor is responsible for doing a take-off of the attached plans. Plant list provided is for guidance only. Landscape Contractor, in submitting a proposal based on these plans, is responsible for all materials as noted on plans.
- Discrepancies shall be brought to the attention of the Landscape Architect.
- No changes shall be made without the prior consent of the Landscape Architect & FDOT Landscape Architect.
- All planting beds shall be treated w/ a pre-emergent herbicide as approved by the Landscape Architect.
- Landscape Contractor is responsible for coordinating with the General Contractor or Owner any and all conditions which may affect the scope of work.
- Landscape contractor shall include in bid all materials and labor as required to complete the job as indicated on the plans and as directed by the General Contractor. Bid shall include, but not be limited to, plant materials, planting soil and placement, fertilizers, drainage mat, protection board, mulch, plants and other accessories as may be required.
- All plant material shall meet or exceed specifications listed.
- All planted beds shall receive 100% coverage by fully automatic irrigation system as per plans.
- Landscape Contractor shall be responsible for providing temporary watering provisions until such time as the irrigation system is operational.
- R.O.W. WORK & PLANT MATERIAL TO MEET ALL CRITERIA & SPECIFICATIONS FOR FDOT WORK AND

PLANTING DETAILS



palm/large tree planting detail



shrub planting detail

PLANT LIST - FDOT R.O.W.

2	qr	Quercus virginiana - Live Oak (N)
		20-22' ht. x 10-12" spr. full head 14.5" c.t. 6-6" dbh
36	ara	Arachis glabrata - Perennial Peanut
		1-2' ht. x 16-12" spr. full 12" o.c.
59	asp	Asparagus 'Myers' - Myers Asparagus
		14-16" ht. x spr. full 16" o.c.
32	lr	Liriope 'Evergreen Giant' - Giant Liriope
		10-12" ht. x spr. full clump 12" o.c.
20	ner	Neoregelia 'Fireball' - Same
		10-12" ht. x spr. full clump 12" o.c.
41	tra	Tracheloperrum asiaticum - Dwarf Confederate Jasmine
		1-2' ht. x 10-12" spr. full 12" o.c.

PLANT LIST - OVERHANGS FDOT R.O.W.

1	pzt	Phoenix 'Zahedi' - Zahedi Date Palm
		16' c.t. matched

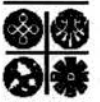

William A Eager
 ARCHITECT
 1000 S. W. 10th Ave
 Fort Lauderdale, FL 33301
 Phone: 954.574.1111
 Fax: 954.574.1112

FDOT PLANTING NOTES



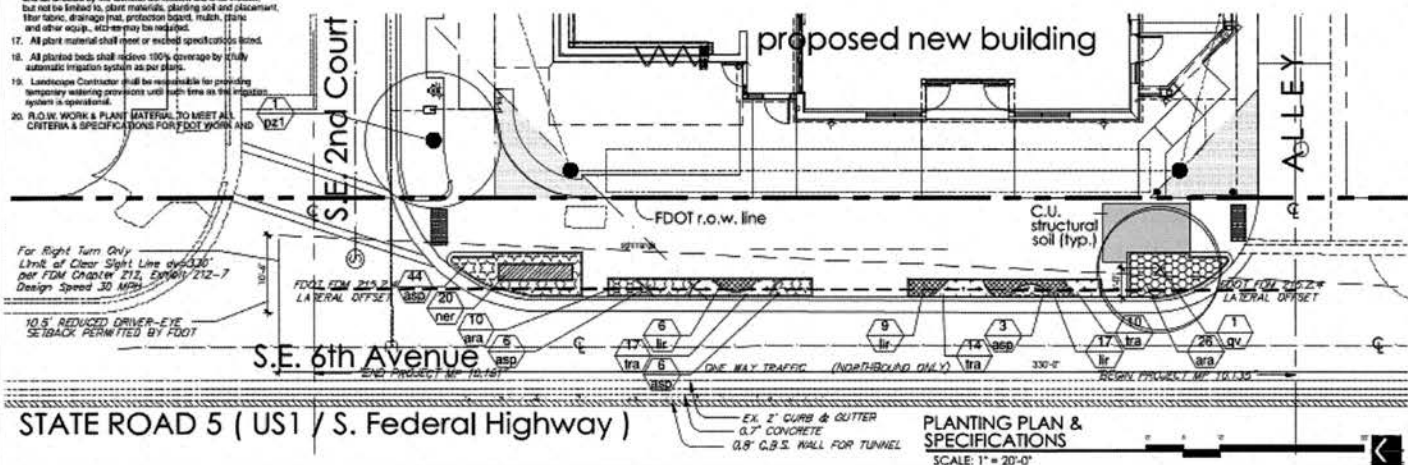



- For the portion of landscape material that will be installed within the FDOT Right of Way, landscape installation shall comply with current applicable FDOT maintenance Specification 580. Online reference: https://fdotwww.blob.core.windows.net/sitefinity/docs/default-source/programmanagement/maintenance/jan22/sms580000wd-122.pdf?sfvrsn=414b7013_2
- For the portion of landscape plant material that will be installed within the FDOT Right of Way refer to FDOT Standard Plans Index 580-001 Landscape Installation. Online Reference: <http://fdotwww.blob.core.windows.net/sitefinity/docs/default-source/design/standardplans/2023/idx/580-001.pdf#>
- Cypress Mulch is not permitted on FDOT right of Way. Mulch permitted to be used are Hardwood Mulch (containing no Cypress products), Recycled Mulch or approved equal, certified by the Mulch and Soil Council (MSC). Submit proof of certification to the FDOT District Operations Permit Landscape Inspector upon inspection.



NEW BUILDING FOR:
PARK PLAZA
 800 S.E. 2nd St., COURT
 FORT LAUDERDALE, FLORIDA 33301

REVISIONS
 01-09-2023
 30106 L
L-3.0 FDOT

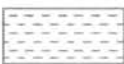
IRRIGATION LEGEND

QTY	SYM	DESCRIPTION	DEL.
	M	LINE SIZE BY 2" TAP, MAXIMUM 10' OF 2" POLYETHYLENE SERVICE LINE AND A PROPOSED 1" POTABLE WATER METER (ALL BY OTHERS)	
1		1" FEBCO 765 PRESSURE VACUUM BREAKER BACKFLOW ASSEMBLY	A
		CLASS 200 PVC LATERAL LINE W/ SCH 40 SOLVENT WELD PVC FITTINGS (SIZE PER PLAN, MINIMUM PIPE SIZE SHALL BE 3/4", NO 1/2" PIPES PERMITTED)	L
		1-1/2" SCHEDULE 40 SOLVENT-WELD PVC MAINLINE W/SCH 40 SOLVENT-WELD PVC FITTINGS	L
		SCH 40 GRAY PVC ELECTRICAL CONDUIT, WITH SCH 40 PVC FITTINGS (SIZE PER PLAN)	L
		NETAFIM TLHCVXR7-CS-12, PRESSURE COMPENSATING LANDSCAPE DRIPLINE WITH COPPER STRIPE, CHECK VALVE, ANTI-SIPHON FEATURE AND 0.77 GPH EMITTERS AT 12" O.C. SPACING. DRIPLINE LATERALS SPACED AT 12" APART, WITH EMITTERS OFFSET FOR TRIANGULAR GRID EMITTER PATTERN. DRIP ZONES INSTALLED WITH DRIP OPERATION INDICATORS. REFER TO PLAN DETAILS	M,N
		CLASS 200 PVC HEADER W/SCH 40 SOLVENT-WELD PVC FITTINGS (SIZE PER PLAN)	M,N
		CLASS 200 PVC SLEEVES W/SCH 40 SOLVENT-WELD PVC FITTINGS (SIZE PER PLAN)	O
NOTE: EVERY MAINLINE SLEEVE/SLEEVE LOCATION SHALL BE ACCOMPANIED BY AN ADDITIONAL 2" SLEEVE FOR IRRIGATION CONTROL WIRES			
QUANTITIES GIVEN ARE FOR CONTRACTOR CONVENIENCE ONLY. THE ACCURACY IS NOT GUARANTEED. ALL QUANTITIES SHALL BE VERIFIED.			

IRRIGATION LEGEND



HSR
HARRISON CONSULTING LLC
Water Management Consultants
200 N. Washington, Suite F
Tampa, FL 33604
Telephone (813) 288-1155
Fax (813) 288-5147



ARCHITECTURAL ALLIANCE
ARCHITECTS
1120 N. WASHINGTON AVENUE, SUITE 100
TAMPA, FLORIDA 33604
PH: (813) 288-1155
FAX: (813) 288-5147

William A Eager
Professional Engineer
No. 12400
FLORIDA
600 SE 2nd Rd. COURT
FORT LAUDERDALE, FLORIDA 33301

NEW BUILDING FOR:
PARK PLAZA
600 SE 2nd Rd. COURT
FORT LAUDERDALE, FLORIDA 33301

DATE: 02-09-2023
PROJECT: 202306 L
DRAWING: IR-1.0
FDOT

FDOT IRRIGATION NOTES

1. The irrigation system shall use the lowest quality water available which adequately and safely meets the water needs of the system. Storm water, reclaim water, or grey water irrigation shall be used whenever possible.
2. FDOT requires 24 hour emergency access to water source.
3. Contractor shall provide FDOT District Operations manager with a set of "As-Built" irrigation plans.



Masuen Consulting LLC
Water Management Consultants

301 S. Washington, Suite F
 Newport, WA 99156
 Telephone (866) 828-1533
 Fax (800) 828-1534

PROFESSIONALLY ENGINEERED AND PROVIDED IN THE USA



811 **KNOW WHAT'S BELOW**
ALWAYS CALL 811
BEFORE YOU DIG

It's not too late to dig.
 Call 811 for assistance before digging.



ARCHITECTURAL ALLIANCE
 ARCHITECTS

William A Eager

NEW BUILDING FOR:
PARK PLAZA
 6.0.0 S.E. 2nd FORT LAUDERDALE, FLORIDA 33301

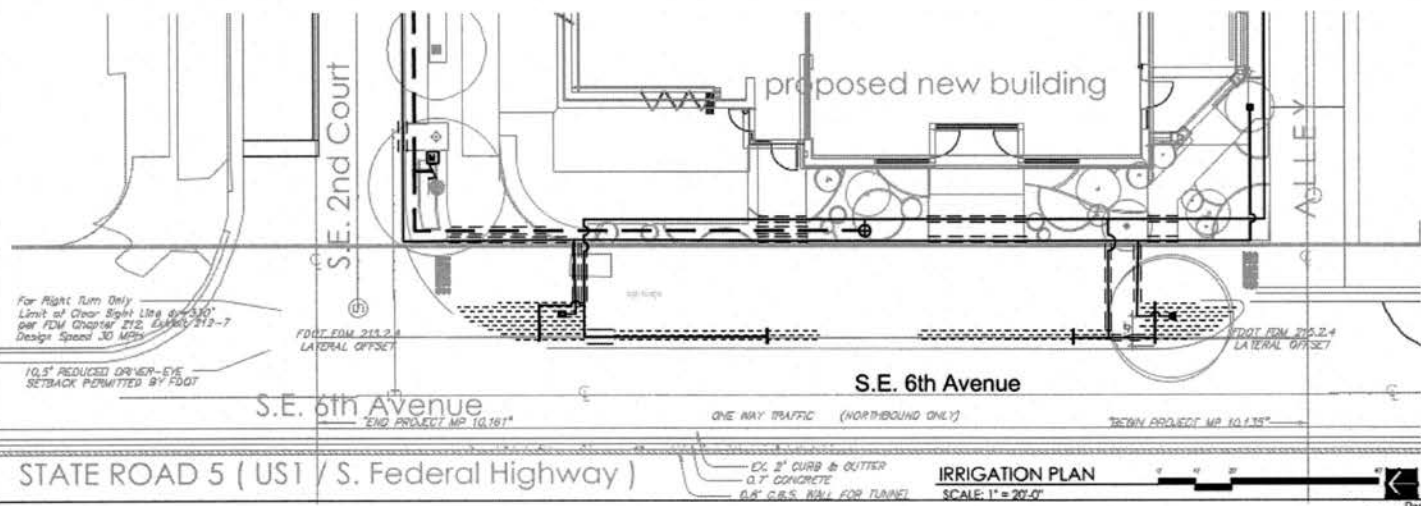

IRRIGATION PLAN
 SCALE: 1" = 20'-0"

Kona Consulting LLC
 1000 S. University Ave., Suite 100
 Fort Lauderdale, FL 33328
 Phone: 754.341.1111
 Fax: 754.341.1112
 Email: info@konaconsulting.com

Villa m/a
 1000 S. University Ave., Suite 100
 Fort Lauderdale, FL 33328
 Phone: 754.341.1111
 Fax: 754.341.1112
 Email: info@villa.com

Eager
 1000 S. University Ave., Suite 100
 Fort Lauderdale, FL 33328
 Phone: 754.341.1111
 Fax: 754.341.1112
 Email: info@eager.com

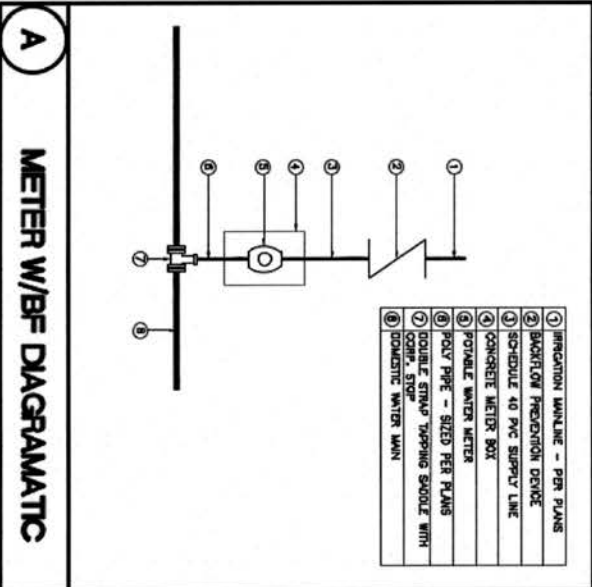
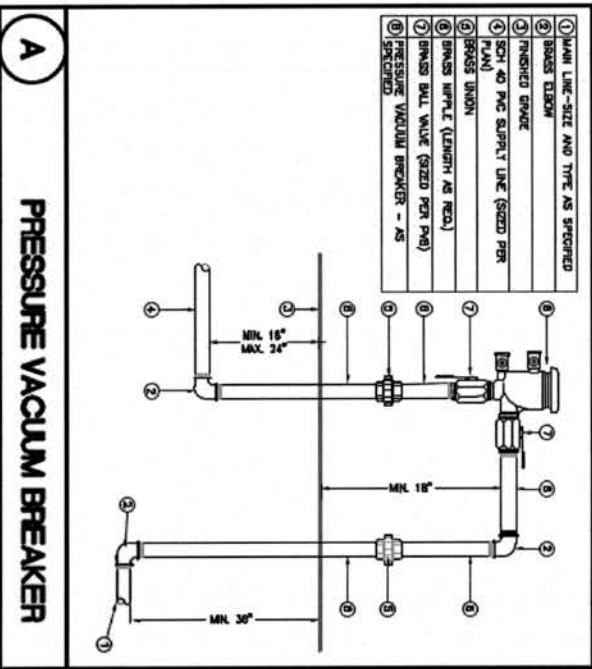

IRRIGATION DETAILS

CAM # 240332
 Exhibit 2
 Page 36 of 54

NEW BUILDING FOR:
P A R K P L A Z A
 800 SE 2ND COURT
 FORT LAUDERDALE, FLORIDA 33301

01-04-2013
 18206.1
 IR-3.0
 FDOT



ARCHITECTURAL ALLIANCE

Wason Consulting LLC
 Water Management Consultants
 201 N. Washington Blvd. F
 Room 10, 3340
 West Palm Beach, FL 33411
 Phone: 561-833-8800
 Fax: 561-833-8801
 www.wasonconsulting.com



ARCHITECTURAL ALLIANCE

William A Eager

ARCHITECT

NEW BUILDING FOR:
PARK PLAZA
 800 SE 2nd COURT
 FORT LAUDERDALE, FLORIDA 33301

DATE: 02-09-2023
 PROJECT: 10106 L

IR-4.0
 FDOT

NOTE:
 REFER TO PRODUCT LITERATURE FOR ADDITIONAL INSTALLATION AND ADJUSTMENT INFORMATION.

ALL SCH 80 NIPPLES ARE TO BE CONTINUOUS AND THREADED ON BOTH SIDES

THE INTENT OF THE FABRIC IS TO KEEP THE VALVE BOX FREE OF DIRT/DEBRIS. FILTER FABRIC SHOULD SPAN BASE OF VALVE BOX AND BE SECURED A MINIMUM OF 6" UP FROM BASE VIA DUCT TAPE AROUND SIDES OF VALVE BOX. FABRIC SHOULD CONTAIN NO HOLES EXCEPT FOR WIRE/PIPES AS APPLICABLE.

- ① 30-INCH LINEAR LENGTH OF WIRE, COILED.
- ② 3M DBR/Y-8 CONNECTORS PER MANUFACTURER SPEC.
- ③ NIBCO T-113 BRONZE GATE VALVE.
- ④ REMOTE CONTROL VALVE: RAINBIRD PEB OR PEB-PRS-D (AS DENOTED IN LEGEND).
- ⑤ CARSON 1220 JUMBO VALVE BOX W/ BOLT DOWN LID.
- ⑥ FRESH GRADE/TOP OF MOUND.
- ⑦ SCH 80 PVC UNION.
- ⑧ PVC SCH 80 ELL.
- ⑨ CHRISTY LU. TAG (STATION/CONTROLLER).
- ⑩ COMMON BRICK (1 OF 4).
- ⑪ IRRIGATION MAINLINE - SIZE AND TYPE AS SPECIFIED.
- ⑫ SERVICE TEE - SIZE, TYPE AND MWC PER MAINLINE SPEC.
- ⑬ PVC SCH 80 CLOSE NIPPLE.
- ⑭ SOLVENT WELDED PVC LATERAL PIPE.
- ⑮ 1/2-INCH MINIMUM DEPTH OF 3/4-INCH WASHED GRAVEL.
- ⑯ PVC SCH 80 NIPPLE (SIZE AS REQUIRED).
- ⑰ 363 LANDSCAPE FABRIC TO BE DUCT TAPED TO VALVE BOX EXTERIOR.
- ⑱ PVC SCH 80 THREADED X SLIP FEMALE ADAPTER.

B1 RAIN BIRD RCV W/GATE VALVE

① PRESSURE REGULATOR (PER LEGEND)

NOTE:

DETAIL 'B2' INTENDED TO SHOW ONLY THE ADDITION OF PRESSURE REGULATOR (TO BE INCLUDED FOR ALL DRP IRRIGATION ZONES, TYP)

REFER TO DETAIL 'B1' FOR FULL RCV INSTALLATION SPECIFICATIONS

ELEVATION VIEW - NOT TO SCALE

B2 PRESSURE REGULATOR (DRIP ZONES)

IRRIGATION DETAILS

IRRIGATION DETAILS

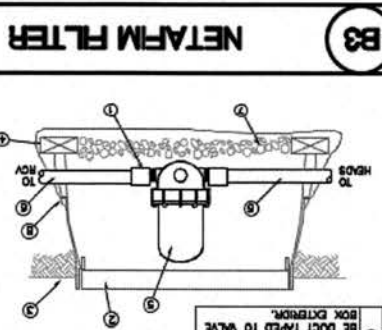

NOTE:
 THE INTENT OF THE FABRIC IS TO KEEP THE VALVE BOX FREE OF DIRT/DEBRIS.
 FILTER FABRIC SHOULD BE SECURED AROUND SIDES OF VALVE BOX VIA DUCT TAPE. MINIMUM OF 8" UP FROM BASE OF VALVE BOX AND BE SECURED AROUND SIDES OF VALVE BOX. BOX FABRIC SHOULD CONTAIN NO HOLES EXCEPT FOR WIRE/PIPES AS APPLICABLE.

- 1) 3/4" PVC SPT FEMALE COUPLER (1 OF 2)
- 2) CARSON 1220 ALUMINUM VALVE BOX W/ BOLT DOWN LUG
- 3) FINISH GRADE/TOP OF WHICH
- 4) COMMON BROCK (1 OF 4)
- 5) NETAFM DISC FILTER
- 6) 1-1/2" (SIZE PER MFG. DIRECTION)
- 7) 3.0" (SIZE PER MFG. DIRECTION)
- 8) 3.0" (SIZE PER MFG. DIRECTION)
- 9) 3.0" (SIZE PER MFG. DIRECTION)
- 10) 3.0" (SIZE PER MFG. DIRECTION)
- 11) 3.0" (SIZE PER MFG. DIRECTION)
- 12) 3.0" (SIZE PER MFG. DIRECTION)
- 13) 3.0" (SIZE PER MFG. DIRECTION)
- 14) 3.0" (SIZE PER MFG. DIRECTION)
- 15) 3.0" (SIZE PER MFG. DIRECTION)

NETAFM FILTER

IR-5.0
 FDOT
 101061
 01-29-2013

NEW BUILDING FOR:
 PARK PLAZA
 600 S.E. 2ND COURT
 FORT LAUDERDALE, FLORIDA 33301

118
 WILLIA
 EAGER
 ALLIANCE



Kramer Consulting LLC
 Water Management Consultants
 201 N. Washington, Suite F
 Pompano Beach, FL 33062
 Phone: (954) 955-1233
 Fax: (954) 955-1234
 www.kramerconsulting.com

William A Eager

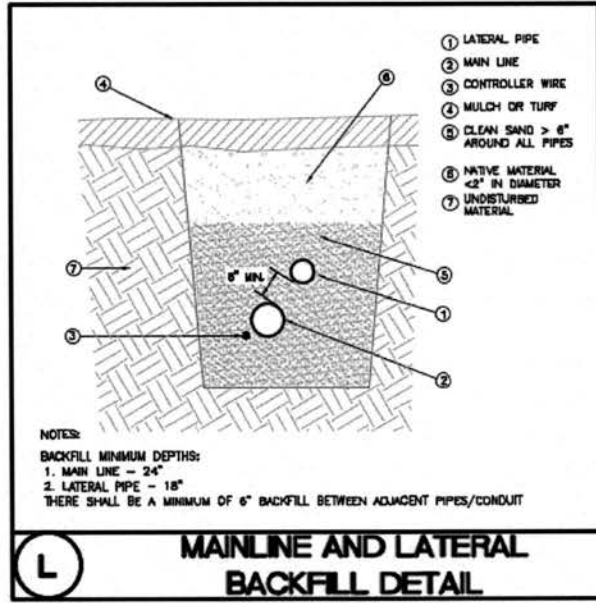
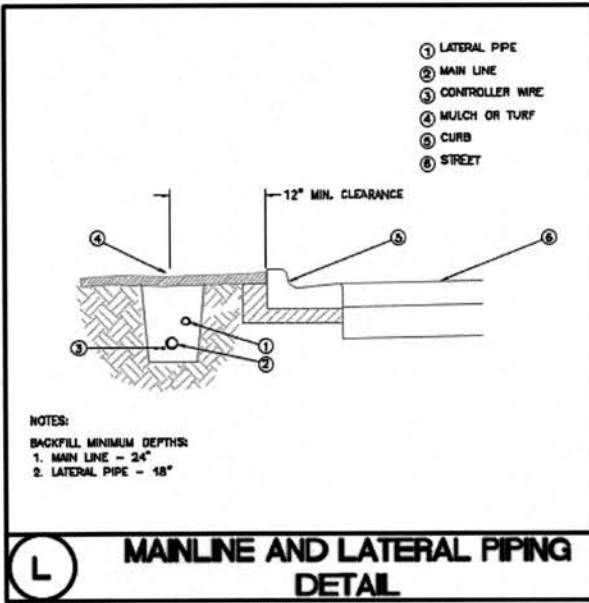
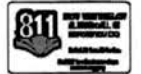

IRRIGATION DETAILS

NEW BUILDING FOR:
PARK PLAZA
 800 S.E. 2ND COURT
 FORT LAUDERDALE, FLORIDA 33301

DATE: 03-09-2023
 PROJECT NO: 10106 L
 IR-6.0
 FDOT



Essex Consulting LLC
 Total Management Solutions
 301 S. Washington, Suite F
 Haverhill, MA 01830
 Telephone: (978) 455-1232
 Fax: (978) 455-1234



ARCHITECTURAL ALLIANCE
 PROFESSIONAL SERVICES

William A Eager

Professional Engineer
 State of Florida
 License No. 12456
 Mechanical
 1000 SE 2nd St., Suite 200
 Fort Lauderdale, FL 33301

NEW BUILDING FOR:
PARK PLAZA
 600 SE 2nd COURT
 FORT LAUDERDALE, FLORIDA 33301

Project No.:
 01-09-2023
 Drawing No.:
 10106 L
 Drawing Title:
IR-7.0
FDOT

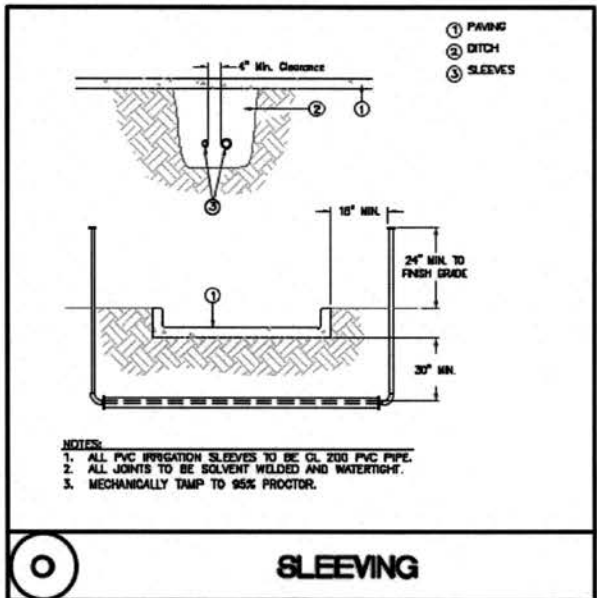
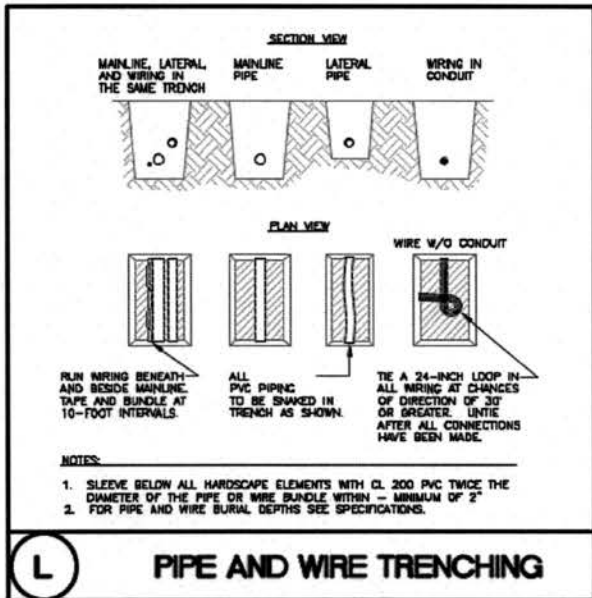

IRRIGATION DETAILS

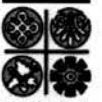

Marion Consulting LLC
 Water Management Consultants
 201 S. Washington, Suite F
 Orlando, FL 32801
 Telephone: 407-837-1111
 Fax: 407-837-1114
 www.marionconsulting.com



ARCHITECTURAL ALLIANCE
 401-1001-1111

William A Eager

Professional Engineer
 No. 12000
 State of Florida
 License No. 12000
 Mechanical
 11/15/2011

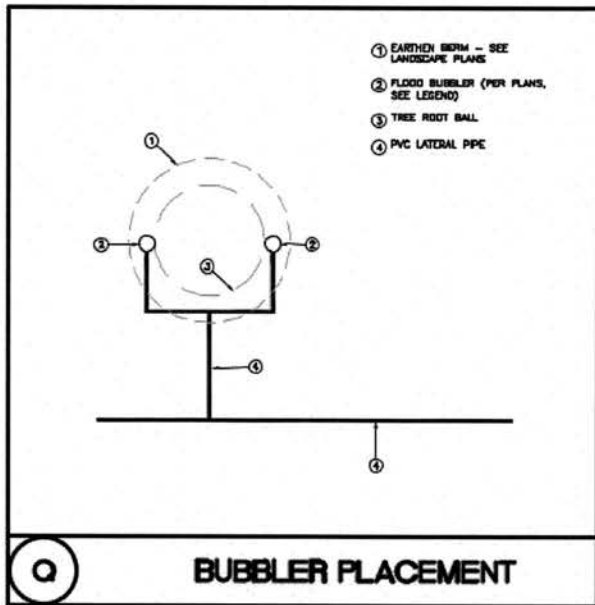
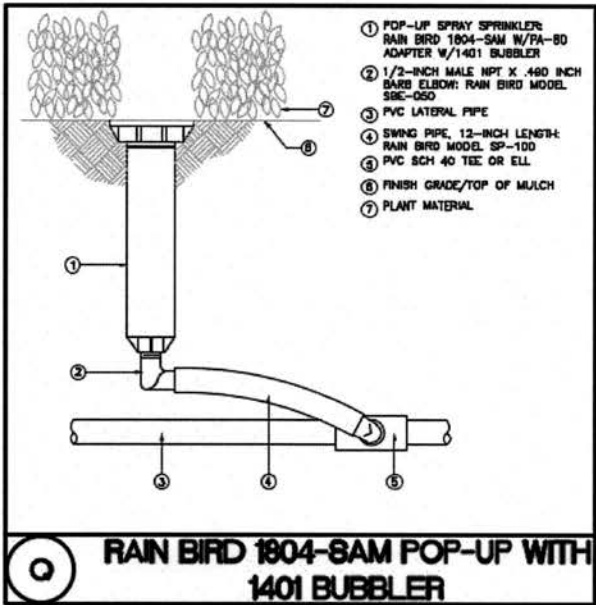

IRRIGATION DETAILS

NEW BUILDING FOR:
PARK PLAZA
 800 S.E. 2nd St., COURT
 FORT LAUDERDALE, FLORIDA 33301

DATE: 01-09-2023
 SHEET NO: 10106 L

IR-8.0
 FDOT

- ① FINISH GRADE
- ② CODELAGE FOR 4" SQUARE, 6" FOR TURF
- ③ TECHLINE BRACING IS 1/2" O.D.
- ④

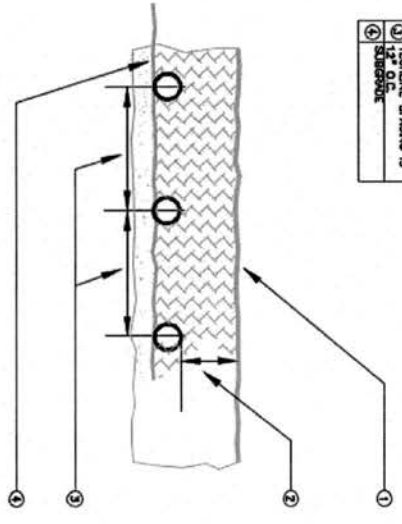

M TECHLINE SUB GRADE LAYOUT

- ① FINISH GRADE
- ② TECHLINE TUBING
- ③ BROOKFIELD TRENCH

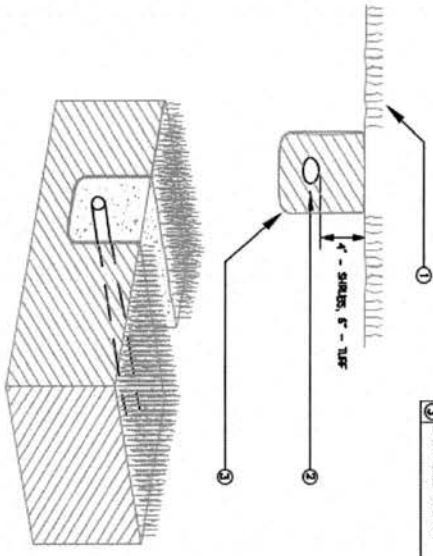

M TECHLINE TRENCHING DETAIL

IRRIGATION DETAILS



NEW BUILDING FOR:
P A R K P L A Z A
 6 0 0 S E 2 n d . C O U R T
 F O R T L A U D E R D A L E , F L O R I D A 3 3 3 0 1

IR-9-0
 FOOT



ES&P

1001 W. 12th Street, Fort Lauderdale, FL 33304

Water Management Consultants

301 S. Washington, Suite F

Fort Lauderdale, FL 33301

Phone: 954-575-1111

Fax: 954-575-1112

www.esandp.com

811

NEW ORLEANS, LA

1000 Poydras Street, Suite 2000

New Orleans, LA 70112

Phone: 504-581-1111

Fax: 504-581-1112

www.esandp.com



ARCHITECTURAL ALLIANCE

1111 N. W. 12th Street, Suite 100

Fort Lauderdale, FL 33301

Phone: 954-575-1111

Fax: 954-575-1112

www.aalliance.com

William A Eager

1000 Poydras Street, Suite 2000

New Orleans, LA 70112

Phone: 504-581-1111

Fax: 504-581-1112

www.aalliance.com

NOTE:

A MINIMUM OF ONE (1) DRIP TUBE FLUSH POINT TO BE INSTALLED IN EVERY DRIP BED/PLANTER BOX LAYOUT AND INSTALLED PER MANUFACTURER SPECIFICATIONS

- ① RAIN BIRD BFCP-1S UNIVERSAL FLUSH CAP ASSEMBLY
- ② 1/2" DRIF TUBING, PER PLANS
- ③ COMMON RED BRICK (1 OF 4)
- ④ CARSON Ø10 ROUND ENCLOSURE WITH BOLT DOWN LID
- ⑤ FINISHED GRADE
- ⑥ 3.0-INCH MINIMUM DEPTH OF 3/4-INCH WASHED GRAVEL
- ⑦ S83 LANDSCAPE FABRIC TO BE DUCT TAPED TO ENCLOSURE EXTERIOR

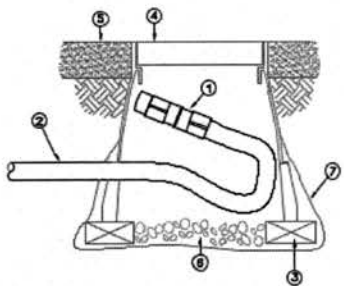

N DRIP TUBE FLUSH POINT

- ① DRIP SYSTEM OPERATION INDICATOR KIT, RAIN BIRD MODEL #OPERIND. INSTALL ONE PER DRIP HEADER, TYP
- ② FINISH GRADE
- ③ MULCH
- ④ DRIFLINE (MAKE/MODEL FOR PLANS)
- ⑤ POTABLE (YELLOW) OR NON-POTABLE (PURPLE) CAP (AS REQUIRED WITH WATER SOURCE)

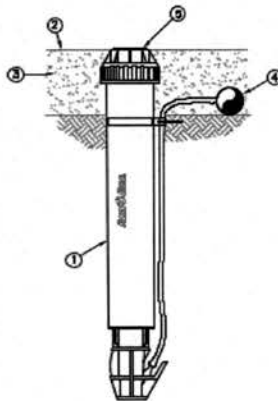

N RAIN BIRD OPERATION INDICATOR

IRRIGATION DETAILS

NEW BUILDING FOR:
PARK PLAZA
 600 S.E. 2ND COURT
 FORT LAUDERDALE, FLORIDA 33301

DATE: 02-09-2023
 10106 L
 IR-10.0
 FDOT

IRRIGATION NOTES & SPECIFICATIONS

THE WORK

The work specified in this section consists of furnishing all components necessary for the installation, testing, and delivery of a complete, fully functional automatic landscape irrigation system that complies with the irrigation plans, specifications, notes, and details. This work shall include, but not be limited to, the providing of all required material if applicable (pump(s), backflows, pipes, valves, fittings, controllers, wire, primer, glue, etc.), layout, protection to the public, excavation, assembly, installation, backfilling, compacting, repair of road surfaces, controller and low voltage feeds to valves, cleanup, maintenance, guarantee and as-built plans.

All irrigated areas shall provide 100% head-to-head coverage from a fully automatic irrigation system with a rain/freeze shut off device. The rain sensor shall be installed to prevent activation by adjacent heads and in a visually un-obtrusive location approved by owner. Zones are prioritized first by public safety and then by hydraulic concerns. This sequencing will be a mandatory punch list item.

These plans have been designed to satisfy/exceed the Florida Building Code (FBC) Appendix F and the Florida Irrigation Society Standards and Specifications for Turf and Landscape Irrigation Systems, fourth edition. All products should be installed per manufacturer's recommendation. Contractor shall verify all underground utilities 72 hours prior to commencement of work.

It is the responsibility of the irrigation contractor to familiarize themselves with all grade differences, location of walls, retaining walls, structures and utilities. Do not willfully install the sprinkler system as shown on the drawings when it is obvious in the field that unknown obstruction, grade differences or differences in the area dimensions exist that might not have been considered in the engineering. Such obstructions, or differences, should be brought to the attention of the owner's authorized representative. In the event this notification is not performed, the irrigation contractor shall assume full responsibility for any revisions necessary.

Irrigation contractor shall repair or replace all items damaged by their work. Irrigation contractor shall coordinate their work with other contractors for the location and installation of pipe sleeves and laterals through walls, under roadways and paving, etc.

The contractor shall take immediate steps to repair, replace, or restore all services to any utilities which are disrupted due to their operations. All costs involved in disruption of service and repairs due to negligence on the part of the contractor shall be their responsibility.

IRRIGATION NOTES



ES2

Karman Consulting LLC
Water Management Consultants
201 S. Mangrove, Suite 100
Boca Raton, FL 33433
Tel: 561-993-1100
Fax: 561-993-1101
www.karmanconsulting.com



ARCHITECTURAL ALLIANCE
ARCHITECTS
1001 N. W. 10th St., Suite 100
Fort Lauderdale, FL 33304
Tel: 954-561-1100
Fax: 954-561-1101
www.aalliance.com

William A Eager
Professional Engineer
No. 12000
FL 12000
12000
12000

12000
12000
12000
12000

NEW BUILDING FOR:
P A R K L A Z A
6 0 0 S E 2 N D C O U R T
F O R T L A U D E R D A L E , F L O R I D A 3 3 3 0 1

Project Number:
30306-L

IR-11.0
FDOT

THE PIPE

Pipe locations shown on the plan are schematic and shall be adjusted in the field. When laying out mainlines place a minimum of 18" away from either the back of curb, front of walk, back of walk, or other hardscape to allow for ease in locating and protection from physical damage. Install all lateral pipe near edges of pavement or against buildings whenever possible to allow space for plant root balls. Always install piping inside project's property boundary.

All pipes are to be placed in planting beds. If it is necessary to have piping under hardscapes, such as roads, walks, and patios, the pipes must be sleeved using Class 200 PVC with the sleeve diameter being twice the size of the pipe it is carrying with a minimum sleeve size of 2". No sleeve shall have turns or fittings that prevent a pipe from being manually pushed/pulled through after it is installed.

Pipe sizes shall conform to those shown on the drawings. No substitutions of smaller pipe sizes shall be permitted, but substitutions of larger sizes may be approved. All damaged and rejected pipe shall be removed from the site at the time of said rejection.

Mainline shall be Sch 40 solvent-weld 1-1/2" PVC with Sch 40 PVC solvent-weld fittings.

Contractor to ensure all mainline piping is properly restrained using mechanical joint fittings, restraining collars, threaded rods, thrust blocks, etc., as and where required. Contractor shall refer to pipe manufacturers recommended installation practices for further direction.

PVC pipe joint compound and primer: The PVC cement shall be Weld-On 711 (grey, slow-drying, heavy duty) and the primer shall be Weld-On P70 (purple tinted, compatible with cement), or approved equals.

TRENCHING

Excavate straight and vertical trenches with smooth, flat or sloping bottoms. Trench width and depth should be sufficient to allow for the proper vertical and horizontal separation between piping as shown in the pipe installation detail on the detail sheet.

Protect existing landscaped areas. Remove and replant any damaged plant material upon job completion. The replacement material shall be of the same genus and species, and of the same size as the material it is replacing. The final determination as to what needs to be replaced and the acceptability of the replacement material shall be solely up to the owner or owner's representative.

IRRIGATION NOTES



BSS
BENTON & BOWLES
SMITH

Hennen Consulting LLC
Water Management Consultants
301 S. Washington, Suite 7
Tampa, FL 33602
Telephone: 813-288-1122
Fax: 813-288-1123

ARCHITECTURAL ALLIANCE
ARCHITECTS
1000 N. W. 10th Street
Fort Lauderdale, FL 33301
Phone: 954-561-1111
Fax: 954-561-1112

William A Eager
Professional Engineer
1000 N. W. 10th Street
Fort Lauderdale, FL 33301
Phone: 954-561-1111
Fax: 954-561-1112

811
NEW ORLEANS
METROPOLITAN
SEWER & WATER
DEPARTMENT

NEW BUILDING FOR:
PARK PLAZA
600 SE 2ND ST., COURT
FORT LAUDERDALE, FLORIDA 33301

ISSUE DATE: 01-09-2003
PROJECT NUMBER: 10106 L
DRAWING NUMBER: IR-12.0
DOT: FDOT

BACKFILL

The Backfill 6" below, 6" above, and around all piping shall be of clean sand and anything beyond that in the trench can be of native material but nothing larger than 2" in diameter. In all planting beds backfill all trenches to 85% Proctor and all trenches under hardscapes to be backfilled and compacted to 95% Proctor.

Mainline pipe depth measured to the top of pipe shall be:

- 24" minimum for 3/4"-2 1/2" PVC with a 30" minimum at vehicular crossings;

Lateral line depths measured to top of pipe shall be:

- 18" minimum for 3/4"-3" PVC with a 30" minimum at vehicular crossings.

Contractor shall backfill all piping, both mainline and laterals, prior to performing any pressure tests. The pipe shall be backfilled with the exception of 2' on each side of every joint (bell fittings, 90's, tees, 45's, etc.). These joints shall not be backfilled until all piping has satisfactorily passed its appropriate pressure test as outlined below.

GUARANTEE

The irrigation system shall be guaranteed for a minimum of one calendar year from the time of final acceptance.

IRRIGATION NOTES

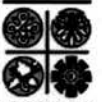

NEW BUILDING FOR:
PARK PLAZA
600 S.E. 2nd Drd. COURT
FORT LAUDERDALE, FLORIDA 33301

05-09-2013
30306 L

IR-13.0
FDOT

SECTION: 86010000
PERMIT: 2023-L-491-00005
COUNTY: Broward
STATE RD: 5

EXHIBIT C

MAINTENANCE PLAN FOR LANDSCAPE IMPROVEMENTS

This Exhibit forms an integral part of the DISTRICT FOUR (4) LANDSCAPE MAINTENANCE MEMORANDUM OF AGREEMENT between the Florida Department of Transportation and the AGENCY.

Please see attached

MAINTENANCE PLAN

Landscape Improvements

Project State Road No(s): SR 5 (US 1 /Federal Highway) from M.P. 10.135 to M.P. 10.161
Permit or FM No(s): 2023-L-491-00005
RLA of Record: William A. Eager, PLA
Maintaining Agency: City of Fort Lauderdale
Date: March 6, 2024

The purpose of a plan for the landscape improvements maintenance practices is to allow the plant material on your project to thrive in a safe and vigorous manner while fulfilling their intended purpose and conserving our natural resources. Plantings and all other landscape improvements within FDOT right of way shall be maintained to avoid potential roadway hazards and to provide required clear visibility, accessibility, clearance, and setbacks as set forth by Florida Department of Transportation (FDOT) governing standards and specifications: FDOT Standard Plans, FDOT Plans Design Manual and FDOT Standard Specifications for Road and Bridge Construction, as amended by contract documents, and all other requirements set forth by the District 4 Operations Maintenance Engineer.

Part I of the Maintenance Plan describes general maintenance requirements and recommendations that are standard for all projects. Part II provides recommendations prepared by the Registered Landscape Architect of Record specific to the attached approved plans.

PART I. GENERAL MAINTENANCE REQUIREMENTS AND RECOMMENDATIONS:

WATERING REQUIREMENTS

Watering is a critical concern for not only the maintenance of healthy plant material but also for observing water conservation practices. The amount of water to apply at any one time varies with the weather, drainage conditions and water holding capacity of the soil. For plant materials that have been established, it is imperative that any mandated water restrictions be fully conformed to on FDOT roadways.

Proper watering techniques should provide even and thorough water dispersal to wet the entire root zone, but not saturate the soil or over-spray onto travel lanes.

IRRIGATION SYSTEM

The Agency shall ensure there are no roadway overspray or irrigation activities during daytime hours (most notably "rush hour" traffic periods). It is imperative the irrigation controller is properly set to run early enough that the watering process will be entirely completed before high traffic periods, while adhering to mandated water restrictions. To ensure water conservation, the Agency shall monitor the system for water leaks and the rain sensors to ensure they are functioning properly so that the system shuts down when there is sufficient rainfall.

MULCHING

Mulch planting beds to prevent weed growth, retain moisture to the plants, protect against soil erosion and nutrient loss, maintain a more uniform soil temperature, and improve the appearance of the planting beds. Do not mound mulch against the trunks of trees, palms, and the base of shrubs to allow air movement which aids in lowering disease susceptibility. Cypress mulch is prohibited on state right of way.

INTEGRATED PLANT MANAGEMENT

An assessment of each planting area's soil is recommended to periodically determine the nutrient levels needed to sustain healthy, vigorous plant growth.

Palms, shrubs, trees, and turf areas shall be fertilized in such a manner and frequency to ensure that the plant material remains healthy and vigorously growing. Please be alert to changes in fertilization types per University of Florida, Institute of Food and Agricultural Services (I.F.A.S.) recommendations. Establishment of an integrated pest management program is encouraged to ensure healthy plants, which are free of disease and pests.

PRUNING

All pruning, and the associated safety criteria, shall be performed according to American National Standard Institute (ANSI) A300 standards and shall be supervised by an International Society of Arboriculture (ISA) Certified Arborist. Pruning shall be carried out with the health and natural growth of plant materials in mind, to achieve the FDOT requirements for maintaining clear visibility for motorists, and provide vertical clearance for pedestrian, bicyclist, and truck traffic where applicable. Visibility windows must be maintained free of view obstructions, and all trees and palms must be maintained to prevent potential roadway and pedestrian hazards. All palms are to be kept fruit free. The understory plant materials selected for use within the restricted planting areas (Limits of Clear Sight) are to be mature height in compliance with the *FDM Window Detail*. Vertical clear zones for vegetation heights over roadways and sidewalks must meet the requirements of the *FDOT Maintenance Rating Program (MRP)* standards. See Reference pages. The R.L.A. of Record will provide the specific pruning heights for mature or maintained height and spread of all plant material to achieve the design intent shall be noted in Part II., Specific Project Site Maintenance Requirements and Recommendations.

STAKING AND GUYING

All staking materials are to be removed after one year or as directed by the RLA of Record.). Any subsequent staking and guying activities by the Agency must adhere to *FDOT Standard Plans* guidelines (See Index 580-001). The Agency shall closely monitor staking and guying attachment materials so that they are securely fastened to avoid potential roadway hazards.

TURF MOWING

All grassed areas are to be mowed and trimmed with sufficient frequency to maintain a deep, healthy root system while providing a neat and clean appearance to the urban landscape. All turf efforts, mowing, curb/sidewalk edging and turf condition, must at a minimum, meet *FDOT Maintenance Rating Program (MRP)*.

LITTER CONTROL

The project site shall remain as litter free as practicable. It is recommended to recycle this litter to avoid unnecessary waste by its reuse. Litter removal efforts must meet *FDOT Maintenance Rating Program (MRP)* standards.

WEEDING/HERBICIDE

All planting areas shall be maintained as weed free as practicable by enlisting integrated pest management practices in areas specified on the plans and maintaining proper mulch levels. Extreme care is recommended when using a chemical herbicide to avoid overspray onto plant materials. It is the applicator's responsibility to restore any damage resulting from overspray to the plantings, per the approved plans.

PLANT REPLACEMENT

Plant replacement shall be the same species and specification as the approved plan. Move and replace all plant materials that may conflict with utility relocations and service. Only plants graded Florida #1 or better, per the *Florida Department of Agriculture and Consumer Services, Grades and Standards for Nursery Plants* are permitted on FDOT roadways. Should it become necessary to change the species, a permit is required from FDOT for approval by the FDOT District Landscape Architect.

TREE CELL STRUCTURES

Underground tree cells shall be maintained in such a manner as to prolong the life of the structure and prevent potential safety hazards. If the structures fail or become damaged, they shall be replaced with the same type and specification as the approved plan.

LANDSCAPE ACCENT LIGHTING

Landscape accent lighting shall be maintained in such a manner as to prolong the life of the lighting fixture and prevent potential safety hazards. If the lighting fixtures and their system become damaged, they shall be replaced with the same type and specification as the approved plan. Landscape lighting shall meet requirements for the sea turtle nesting and hatching.

HARDSCAPE (SPECIALTY SURFACING)

All tree grates and specialty surfacing (if applicable) shall be maintained in such a manner as to prevent any potential tripping hazards and protect damage to the surfacing and tree grates. Final surface tolerance from grade elevations shall, at a minimum, meet the most current FDOT Maintenance Rating Program Handbook for a sidewalk; ADA accessible sidewalk; and FDOT Design Standards for Design, Construction, Maintenance and Utility Operations on The State Highway System. If the specialty surfacing or tree grates become damaged, they shall be replaced with the same type and specification as the approved plan.

HARDSCAPE (CONCRETE PAVERS)

All concrete pavers (if applicable) shall be maintained in such a manner as to prevent any potential tripping hazards and protect damage to the pavers. Final surface tolerance from grade elevations shall, at a minimum, meet the most current *Interlocking Concrete Pavement Institute (ICPI), Guide Specifications for Pavers on an Aggregate Base, Section 23 14 13 Interlocking Concrete Pavers*, Part 3.05. If the concrete pavers become damaged, they shall be replaced with the same type and specification as the approved plan.

It shall be the responsibility of the AGENCY to maintain all signs located within a non-standard surfacing area. Such maintenance to be provided by the AGENCY shall include repair and replacement of the sign panel, post, and base.

HARDSCAPE (NON-STANDARD TRAVELED WAY SURFACING)

It shall be the responsibility of the AGENCY to restore an unacceptable ride condition of the roadway, including asphalt pavement (if applicable), caused, or contributed by the installation or failure of non-standard surfacing, and/or the header curb, on the Department of Transportation right of way within the limits of this Agreement. Pavement restoration areas or "patches" will have a minimum length of 10-ft, measured from the edge of the header curb, and a width to cover full lanes for each lane affected by the restoration.

Pavement restoration will be performed in accordance with the most current edition of the *FDOT Standard Specifications for Road and Bridge Construction*, and the *FDOT Design Standards for Design, Construction, Maintenance and Utility Operations on the State Highway System*.

SITE FURNISHINGS

Site furnishing such as Trash Receptacles, Benches, Bollards and Bicycle Racks shall be maintained in such a manner as to prolong the life of the fixture and prevent potential safety hazards. If the fixtures and their overall function and mounting systems become damaged, they shall be replaced with the same type and specification as the approved plan.

MAINTENANCE OF TRAFFIC CONTROL

Reference the FDOT website regarding the selection of the proper traffic control requirements to be provided during routine maintenance and / or new installations of this DOT roadway.

VEGETATION MANAGEMENT AT OUTDOOR ADVERTISING (ODA)

To avoid conflicts with permitted outdoor advertising, please reference the State of Florida website regarding the vegetation management of outdoor advertising. This website provides a portal to search the FDOT Outdoor Advertising Inventory Management System Database. The database contains an inventory of outdoor advertising structures, permits and other related information maintained by the Department.

Also, reference the *Florida Highway Beautification Program* website link for *Vegetation Management at ODA signs* Florida Statutes and Florida Administrative Code related to vegetation management at outdoor advertising sign, permit applications for vegetation management and determining mitigation value of roadside vegetation.

PART II.
SPECIFIC PROJECT SITE MAINTENANCE REQUIREMENTS AND RECOMMENDATIONS

1. Pruning Schedule and Methods:

Live Oak: Pruning shall be limited to removing dead and injured material or structurally weak growth that compromises the health of the tree or poses a hazard to pedestrians or vehicles.

- Maintained at mature height and spread. (Refer to Part I Pruning, for clear sight window and vertical clear zone pruning requirements.)
- The central leader shall not be cut, and all pruning cuts shall be made with a sharp instrument flush with the 'collar' of the branch.
- Remove suckering growth from base and clear trunk areas monthly.

Perennial Peanut and Dwarf Confederate Jasmine:

- Trimmed to maintain a consistent height of 3" to 4", full to ground.
- In no case should the plant bed be reduced below 2" height.

Myers Asparagus, Neoregelia Fireball, and Giant Lilyturf Liriope:

- Trimmed only to remove dead growth.
- Maintain the natural size and growth habit of each species.

2. Groundcover horizontal growth shall be maintained to prevent foliage from growing beyond the limits of the planting areas shown on the plan. Maintain plantings with a 2" setback from the foliage to the edge of curb, pavement, sidewalk and/or other hardscape improvements.
3. Evaluate plant material on a monthly basis for pests, diseases, drought stress or general decline. If required, follow the integrated pest management program established by the Agency to ensure healthy plants.
4. Joints and cracks in concrete sidewalks, concrete curbs, expansion joints, catch basins, gutter areas, etc. shall be inspected on a monthly basis to keep those areas free of weeds.
5. Inspect the irrigation system performance on a monthly basis to ensure the system is providing 100% coverage. Ensure that system does not have sections of low pressure, bubbler and drip tube valves are clean and clear of debris and any damaged irrigation components (i.e., bubblers, drip tube, valve boxes, etc.) are repaired or replaced.

REFERENCES (4-27-20)

This reference list is provided as a courtesy. The list may not contain the most current websites. The most current references must be accessed for up-to-date information.

Accessible Sidewalk (ADA) <http://www.access-board.gov/guidelines-and-standards/streets-sidewalks>

Americans with Disabilities Act (ADA) (ADAAG) http://www.ada.gov/2010ADAstandards_index.htm

American National Standard Institute, *ANSI A300, (Part 1) for Tree Care Operations – Trees, Shrub, and Other Woody Plant Maintenance – Standard Practices (Pruning)*, available for purchase
<http://webstore.ansi.org>

Florida Department of Agriculture and Consumer Services, Division of Plant Industry, *Florida Grades and Standards for Nursery Plants 2015* <http://www.freshfromflorida.com/Divisions-Offices/Plant-Industry/Bureaus-and-Services/Bureau-of-Plant-and-Apiary-Inspection>

Florida Department of Community Affairs (DCA), *Florida Board of Building Codes & Standards, 2017 Florida Building Code, Chapter 11 Florida Accessibility Code for Building Construction Part A*
[http://www.floridabuilding.org/fbc/workgroups/Accessibility Code Workgroup/Documentation/CHAPTER 11 w florida specifics.htm](http://www.floridabuilding.org/fbc/workgroups/Accessibility%20Code%20Workgroup/Documentation/CHAPTER_11_w_florida_specifics.htm)

Florida Department of Transportation, *Program Management, Maintenance Specifications Workbook Supplemental Specifications, Section 580 Landscape Installation*
<http://www.fdot.gov/programmanagement/Maintenance/2019Jan/default.shtm>

Florida Department of Transportation, *FDOT Standard Plans for Design, Construction, Maintenance and Utility Operations on the State Highway System, Index 580-001 Landscape Installation*
<http://www.fdot.gov/design/standardplans/current/IDx/580-001.pdf>

Florida Department of Transportation, *FDOT Design Manual for Design, Construction, Maintenance and Utility Operations on the State Highway System, Chapter 212.11 Clear Sight Triangles*
<http://www.fdot.gov/roadway/FDM/current/2018FDM212Intersections.pdf>

Florida Department of Transportation, *FDOT Design Manual for Design, Construction, Maintenance and Utility Operations on the State Highway System, Chapter 215.2.3 Clear Zone Criteria and 215.2.4 Lateral Offset, Table 215.2.1 Clear Zone Width Requirements, Table 215.2.2 Lateral Offset Criteria (for Trees)*
<http://www.fdot.gov/roadway/FDM/current/2018FDM215RoadsideSafety.pdf>

Florida Department of Transportation, *FDOT Standard Plans for Design, Construction, Maintenance and Utility Operations on the State Highway System, Index Series 102-600 Traffic Control through Work Zones* <http://www.fdot.gov/design/standardplans/current/IDx/102-600.pdf>

Department of Transportation, Landscape Architecture Website www.MyFloridaBeautiful.com

Florida Department of Transportation, *Maintenance Rating Program Handbook*
<http://www.dot.state.fl.us/statemaintenanceoffice/MaintRatingProgram.shtm>

Florida Department of Transportation Outdoor Advertising Database
<http://www2.dot.state.fl.us/rightofway/>

Florida Exotic Pest Plant Council Invasive Plant Lists <http://www.fleppc.org/list/list.htm>

Florida Irrigation Society <http://www.fisstate.org>

Florida Power and Light (FPL), *Plant the Right Tree in the Right Place*
http://www.fpl.com/residential/trees/right_tree_right_place.shtml

SECTION: 86010000
PERMIT: 2023-L-491-00005
COUNTY: Broward
STATE RD: 5

EXHIBIT D

RESOLUTION

This Exhibit forms an integral part of the DISTRICT FOUR (4) LANDSCAPE MAINTENANCE MEMORANDUM OF AGREEMENT between the Florida Department of Transportation and the AGENCY.

Please see attached

(To be provided by City)



COMMISSION AGENDA ITEM
DOCUMENT ROUTING FORM

2L

Today's Date: 4/25/24

DOCUMENT TITLE: RESOLUTION APPROVING A LANDSCAPE MAINTENANCE MEMORANDUM OF AGREEMENT FOR STATE ROAD 5 (US 1/FEDERAL HIGHWAY) WITH FDOT AND AN ASSUMPTION OF LIABILITY AND HOLD HARMLESS AGREEMENT WITH PAWACQCO HOLDINGS 5 LLC

COMM. MTG. DATE: 4/16/24 CAM #: 24-0352 ITEM #: CR-5 CAM attached: YES NO

Routing Origin: CAO Router Name/Ext: Jolene C./5035 Action Summary attached: YES NO

CIP FUNDED: YES NO

Capital Investment / Community Improvement Projects defined as having a life of at least 10 years and a cost of at least \$50,000 and shall mean improvements to real property (land, buildings, or fixtures) that add value and/or extend useful life, including major repairs such as roof replacement, etc. Term "Real Property" include: land, real estate, realty, or real.

1) City Attorney's Office: Documents to be signed/routed? YES NO # of originals attached: 2

Is attached Granicus document Final? YES NO Approved as to Form: YES NO

Date to CCO: 4/25/24 Kimberly Cunningham Mosley
Attorney's Name

Initials

2) City Clerk's Office: # of originals: 2 Routed to: Donna V./Amber C./CMO Date: 04/25/24

3) City Manager's Office: CMO LOG #: APR 58 Document received from: 004/26/24

Assigned to: GREG CHAVARRIA
ANTHONY FAJARDO SUSAN GRANT
GREG CHAVARRIA as CRA Executive Director

APPROVED FOR G. CHAVARRIA'S SIGNATURE N/A FOR G. CHAVARRIA TO SIGN

PER ACM: PER ACM: A. Fajardo (Initial/Date)
PER ACM: S. Grant (Initial/Date)

PENDING APPROVAL (See comments below)

Comments/Questions: _____

Forward 2 originals to Mayor CCO Date: 4/29 + 5/1

4) Mayor/CRA Chairman: Please sign as indicated. Forward 2 originals to CCO for attestation/City seal (as applicable) Date: _____

5) City Clerk: Scan original and forwards 2 originals to: Jolene Chism/CAO/Suite 1605/x.5035

Attach certified Reso # _____ YES NO

Original Route form to Jolene C.