



## Event # 191-4

**Name:** GTL WWTP Deepwell Injection Well Cleaning

**Description:** The City of Fort Lauderdale, Florida (City) is seeking bids from qualified bidders, hereinafter referred to as the Contractor, to provide building/construction services for the City's Public Works Department, in accordance with the terms, conditions, and specifications contained in this Invitation To Bid (ITB).

This project is located at the George T. Lohmeyer Wastewater Treatment Plant (GTL WWTP), 1000 SE 21 Street, Fort Lauderdale, Florida, 33316 in the City of Fort Lauderdale. The work to be accomplished under this solicitation includes, but is not limited to, furnishing all labor, materials and equipment to perform mechanical integrity testing (MIT) of five (5) existing Class I injection wells.

The Injection Wells have a 24-inch outside diameter (OD), 0.500-inch wall thickness injection casing set to total depths of 2,800 to 2,820 feet below land surface (BLS) and were constructed with a nominal 22-inch diameter open borehole extending from the bottom of the casing to approximately 3,305 to 4,010 feet BLS. Also, this project includes the replacement of some piping and painting and required appurtenances at each injection well.

**Buyer:** MARTINEZ, ERICK

**Status:** Pending Award

**Event Type:** IFB

**Currency:** USD

**Sealed Bid:** Yes

**Respond To All Lines:** Yes

**Q & A Allowed:** Yes

**Number Of Amendments:** 4

**Display Bid Tabulation:** Display When Event Closed For Bidding Or Canceled

## Event Dates

**Preview:**

**Q & A Open:** 11/01/2023 11:01:00 AM

**Open:** 11/01/2023 11:00:00 AM

**Q & A Close:** 12/08/2023 05:00:00 PM

**Close:** 12/29/2023 02:00:00 PM

**Dispute Close:**

## Questions

Question	Response Type	Attachment
Did you fill out and attach all required documents?	Yes No	Event 191 Required Forms.pdf
Did you submit proof of all required licenses/certifications per Special Conditions, Section 7?	Yes No	

# Event # 191-4: GTL WWTP Deepwell Injection Well Cleaning

---

## Meetings

Meeting	Description	Location	Date	Required
Pre-Bid Meeting/Site visit	A pre-bid meeting and site visit will be held on Wednesday, December 6, 2023, at 10:00am, local time.	George T. Lohmeyer Regional Wastewater Treatment Plant	12/06/2023 10:00:00 AM	No

## Attachments

Name	Attachment
Event 191 Solicitation	Event 191 - GTL Deepwell Testing.pdf
Addendum 1	Addendum 1 - Event 191.pdf
Addendum 2	Addendum 2 - Event 191.pdf

## Contacts

Name	Email Address
ERICK MARTINEZ	emartinez@fortlauderdale.gov

## Commodity Codes

Commodity Code	Description
909-61	Maintenance and Repair, Non-Residential Building

## Line Details

### Line 1: KILL THE WELL

---

# Event # 191-4: GTL WWTP Deepwell Injection Well Cleaning

---

**Description:** Furnish all materials, labor and equipment for suppressing the well differential back pressure in each of the Floridian Aquifer injection well, as required for all phases of the mechanical integrity testing.

**Item:** KILL THE WELL KILL THE WELL

**Commodity Code:** 909-61 Maintenance and Repair, Non-Residential Building

**Manufacturer Code:** MFC **Division:** DIV

**Quantity:** 5.0000 **Unit of Measure:** EA

**Requested Delivery Date:** 01/31/2024

**Require Response:** Yes

**Price Breaks Allowed:** No

**Allow Alternate Responses:** No

**Add On Charges Allowed:** No

## Line 2: Brush the Casing

---

**Description:** Furnishing all materials, labor and equipment for cleaning the interior casing of each of the Floridian Aquifer injection wells for its entire length for duration and frequency according to plans/specs.

**Item:** BRUSH THE CASING Brush the Casing

**Commodity Code:** 909-61 Maintenance and Repair, Non-Residential Building

**Manufacturer Code:** MFC **Division:** DIV

**Quantity:** 5.0000 **Unit of Measure:** EA

**Requested Delivery Date:** 01/31/2024

**Require Response:** Yes

**Price Breaks Allowed:** No

**Allow Alternate Responses:** No

**Add On Charges Allowed:** No

### Line 3: Pressure Test the Casing

---

**Description:** Furnish all materials, labor and equipment to pressure test the well casing interior of the injection well, for its entire length, including packer mechanical integrity test.

**Item:** PRESSURE TEST THE CASING    Pressure Test the Casing

**Commodity Code:** 909-61    Maintenance and Repair, Non-Residential Building

**Manufacturer Code:** MFC

**Division:** DIV

**Quantity:** 5.0000

**Unit of Measure:** EA

**Requested Delivery Date:** 01/31/2024

**Require Response:** Yes

**Price Breaks Allowed:** No

**Allow Alternate Responses:** No

**Add On Charges Allowed:** No

### Line 4: RADIOACTIVE TRACER SURVEY

---

**Description:** Furnish all materials, labor and equipment for performing a temperature log and radioactive tracer survey at each injection well.

**Item:** RADIOACTIVE TRACER SURVEY    RADIOACTIVE TRACER SURVEY

**Commodity Code:** 909-61    Maintenance and Repair, Non-Residential Building

**Manufacturer Code:** MFC

**Division:** DIV

**Quantity:** 5.0000

**Unit of Measure:** EA

**Requested Delivery Date:** 01/31/2024

**Require Response:** Yes

**Price Breaks Allowed:** No

**Allow Alternate Responses:** No

**Add On Charges Allowed:** No

## Line 5: Video Survey

---

**Description:** Furnish all materials, labor and equipment for performing a closed-circuit television survey of the Floridian Aquifer injection well interior casing for its full length and the open borehole to its full depth pre-brushing and post-brushing.

**Item:** VIDEO SURVEY Video Survey

**Commodity Code:** 909-61 Maintenance and Repair, Non-Residential Building

**Manufacturer Code:** MFC

**Division:** DIV

**Quantity:** 10.0000

**Unit of Measure:** EA

**Requested Delivery Date:** 01/31/2024

**Require Response:** Yes

**Price Breaks Allowed:** No

**Allow Alternate Responses:** No

**Add On Charges Allowed:** No

## Line 6: Painting

---

**Description:** Furnish all materials, labor, tools, ladders, scaffolding, required for painting all pipes, fittings, valves, surge tanks, and other appurtenances for five deep injection wells.

**Item:** PAINTING Painting

**Commodity Code:** 909-61 Maintenance and Repair, Non-Residential Building

**Manufacturer Code:** MFC

**Division:** DIV

**Quantity:** 1.0000

**Unit of Measure:** LS

**Requested Delivery Date:** 01/31/2024

**Require Response:** Yes

**Price Breaks Allowed:** No

**Allow Alternate Responses:** No

**Add On Charges Allowed:** No

### Line 7: Pipe Replacement

---

**Description:** Furnish all labor, material, and equipment to replace the piping and complete other repairs as necessary per the figures.

**Item:** PIPE REPLACEMENT Pipe Replacement

**Commodity Code:** 909-61 Maintenance and Repair, Non-Residential Building

**Manufacturer Code:** MFC

**Division:** DIV

**Quantity:** 1.0000 **Unit of Measure:** LS

**Requested Delivery Date:** 01/31/2024

**Require Response:** Yes

**Price Breaks Allowed:** No

**Allow Alternate Responses:** No

**Add On Charges Allowed:** No

### Line 8: Mobilization/Demobilization

---

**Description:** Mobilization includes required field coordination and project management, submittals, RFIs, insurance, site cleanup, sanitary facilities, bonds, video, labor associated with permit acquisition, staging area, testing, construction trailer and demobilization; not to exceed 5% of the base bid. 50% paid when contractor is onsite; 50% at final completion.

**Item:** MOBILIZATION/DEMOBILIZATION Mobilization/Demobilization

**Commodity Code:** 909-61 Maintenance and Repair, Non-Residential Building

**Manufacturer Code:** MFC

**Division:** DIV

**Quantity:** 1.0000 **Unit of Measure:** LS

**Requested Delivery Date:** 01/31/2024

**Require Response:** Yes

**Price Breaks Allowed:** No

**Allow Alternate Responses:** No

**Add On Charges Allowed:** No

**CITY OF FORT LAUDERDALE**  
**CONTRACT AND SPECIFICATIONS PACKAGE**

---

**BID/EVENT NO. 191**

**PROJECT NO. P12798**

**George T. Lohmeyer WWTP**  
**Deep Injection Well**  
**Cleaning**



**Erick Martinez**  
**Senior Procurement Specialist**  
Telephone: (954) 828-4019 E-mail: [emartinez@fortlauderdale.gov](mailto:emartinez@fortlauderdale.gov)

**TABLE OF CONTENTS**

<b><u>Description</u></b>	<b><u>Pages</u></b>
<b>I. BID INFORMATION</b>	
Invitation to Bid .....	IB-1
Instruction to Bidders .....	ITB-1
General Conditions .....	GC-1
Special Conditions .....	SC1
<b>II. CONSTRUCTION AGREEMENT (SAMPLE).....</b>	<b>C-1</b>
<b>III. TECHNICAL SPECIFICATIONS</b>	
011101 Summary of Work.....	TS-1
012000 Measurement and Payment.....	TS-18
099100 Painting .....	TS-24
332113 Mechanical Integrity Testing .....	TS-28
Drawings.....	TS-36

**Note:** The following documents are available electronically for completion and **must** be returned with your bid along with your bid security, proof of insurance, and proof of required licenses/certifications.

- Plans Request Form
- Construction Bid Certification Page
- CITB Questionnaire Sheet
- CITB Specific References
- Non-Collusion Statement
- Non-Discrimination Certification Form
- E-Verify Statement
- Contract Payment Method



## **INVITATION TO BID**

Sealed bids will be received electronically until **2:00 p.m.**, local time, on **December 4, 2023**, and opened online immediately thereafter for **BID/EVENT NO., 191, PROJECT NO., P12798, George T. Lohmeyer WWTP Deep Injection Well Cleaning.**

All openings will be held on the City's online strategic sourcing platform. Once the Procurement Specialist opens the solicitation, the bid tabulations may be viewed immediately on a computer, laptop, cell phone, or any other device with Wi-Fi access. In the event of any conflict or discrepancy between bid price(s) submitted by bidder electronically into the City's online strategic sourcing platform Unit Price field(s), any other forms or attachments (whether part of the City's solicitation documents or documents created and uploaded by the bidder, or another section/field of the System, the online unit price(s) **inputted** electronically into the System by the bidder shall govern.

Anyone requesting assistance or having further inquiry in this matter must contact the Procurement Specialist indicated in the solicitation, via the Question and Answer (Q&A) forum on the City's online strategic sourcing platform before the Last Day for Questions indicated in the Solicitation.

This project is located at the George T. Lohmeyer Wastewater Treatment Plant (GTL WWTP), 1000 SE 21 Street, Fort Lauderdale, Florida, 33316 in the City of Fort Lauderdale. The work to be accomplished under this solicitation includes, but is not limited to, furnishing all labor, materials and equipment to perform mechanical integrity testing (MIT) of five (5) existing Class I injection wells.

The Injection Wells have a 24-inch outside diameter (OD), 0.500-inch wall thickness injection casing set to total depths of 2,800 to 2,820 feet below land surface (BLS) and were constructed with a nominal 22-inch diameter open borehole extending from the bottom of the casing to approximately 3,305 to 4,010 feet BLS. Also, this project includes the replacement of some piping and painting and required appurtenances at each injection well.

### **Drawing Plans:**

The City of Fort Lauderdale's George T. Lohmeyer Wastewater Treatment Plant is a secured facility and is exempt from the Public Records Law, pursuant to FL Statute Chapter 119.071. Interested parties must log on to the City's online strategic sourcing platform to access the City of Fort Lauderdale Plan & Specification Request Form AND must follow instructions contained therein.

Access to the site visit is only available to pre-approved plan holders originating from the City of Fort Lauderdale Plans Request Form. Non-approved attendees will not be allowed to participate in the site visit. To avoid any issues, Plans Custodians should bring proof of approval to the site visit.

**Licensing Requirements:** Geophysical Contractor holding a valid State of Florida Water Well Contractor License issued by the South Florida Water Management District is required for this Project.

**NOTE: Payment on this contract will be made by Visa or MasterCard.**

**Pre-Bid Meeting/Site visit:** A pre-bid meeting and site visit will be held on Thursday, November 16, 2023 at 10:00am, local time, at:

**George T. Lohmeyer Regional Wastewater Treatment Plant**  
1765 SE 18th St  
Fort Lauderdale, FL 33316

While attendance is not mandatory, it is strongly suggested that all contractors attend the pre-bid conference. It will be the sole responsibility of the bidder to inspect the City's location and become familiar with the scope of the City's requirements and systems prior to submitting a bid. No variation in price or conditions shall be permitted based upon a claim of ignorance. Submission of a bid will be considered evidence that the bidder has familiarized himself with the nature and extent of the work, equipment, materials, and labor required.

**Bid Security:** A certified check, cashier's check, bank officer's check or bid bond for **FIVE (5%) percent** of the bid amount, made payable to the City of Fort Lauderdale, Florida, shall accompany each offer.

**Bid Bonds:**

Bidders can submit bid bonds three different ways:

- 1) Bidders may submit bid bonds **electronically** directly through the City's online strategic sourcing platform using **Surety 2000**.
- 2) Bidders may **upload** their original executed bid bond on the City's online strategic sourcing platform to accompany their electronic bids, and **mail** the original, signed and sealed hard copy to the Finance Department, Procurement Services Division, 1 East Broward Blvd, Suite 444, Fort Lauderdale FL, 33301, **within five (5) business days** after bid opening, with the company name, bid number and title clearly indicated on the envelope.
- 3) Bidders can **mail** their bid bond to the Finance Department, Procurement Services Division, 1 East Broward Blvd, Suite 444, Fort Lauderdale FL, 33301, **before time of bid opening**, with the company name, bid number and title clearly indicated on the envelope. **NOTE: Bond must be received in Procurement and time stamped before bid opening.**

It will be the sole responsibility of the bidder to ensure that its bid is submitted prior to the bid opening date and time listed. **PAPER BID SUBMITTALS WILL NOT BE ACCEPTED. BIDS MUST BE SUBMITTED ELECTRONICALLY VIA THE CITY'S ONLINE STRATEGIC SOURCING PLATFORM.**

**Certified Checks, Cashier's Checks and Bank Drafts:**

These **CANNOT** be submitted via the City's online strategic sourcing platform, nor are their images allowed to be uploaded and submitted with your electronic bid. These forms of securities, as well as hard copy bid bonds, must be received on or before the Invitation to Bid (ITB) opening date and time, at the Finance Department, Procurement Services Division, 521 NE 4<sup>th</sup> Avenue, Fort Lauderdale, Florida 33301-1016, with the bid number and title clearly indicated on the envelope.

It is the bidder's sole responsibility to ensure that its bid bond or other bid security is received by the Procurement Services Division before the time of bid opening. Failure to adhere to this requirement may be grounds to consider the bid as non-responsive.

The City of Fort Lauderdale reserves the right to waive any informality in any or all bids and to reject any or all bids.

For information concerning technical specifications, please utilize the Q&A platform provided on the City's online strategic sourcing platform. Questions of a material nature must be received prior to the cut-off date specified in the solicitation. Material changes, if any, to the scope of services or bidding procedures, will only be transmitted by written addendum. **Bidders please note:** No part of your bid can be submitted via FAX. No variation in price or conditions shall be permitted based upon a claim of

ignorance. Submission of a bid will be considered evidence that the bidder has familiarized himself with the nature and extent of the work, equipment, materials, and labor required. The entire bid response must be submitted in accordance with all specifications contained in this solicitation.

Information on bid results and projects currently out to bid can be obtained on the City's website – <https://www.fortlauderdale.gov/government/departments-a-h/finance/procurement-services>  
For general inquiries, please call (954) 828-5933.

**-BALANCE OF PAGE INTENTIONALLY LEFT BLANK-**

## **INSTRUCTIONS TO BIDDERS**

The following instructions are given for the purpose of guiding bidders in properly preparing their bids or proposals. These directions have equal force and weight with the specifications, and strict compliance is required with all of these provisions.

**QUALIFICATIONS OF BIDDERS** – No bid will be accepted from, nor will any contract be awarded to, any person who is in arrears to the City of Fort Lauderdale, upon any debt or contract, or who has defaulted, as surety or otherwise, upon any obligation to the City, or who is deemed irresponsible or unreliable by the City Commission of Fort Lauderdale.

**CONCERNING SUB-CONTRACTORS, SUPPLIERS, AND OTHERS** - The amount of work that is sublet by the Bidder shall be limited by the condition that the Bidder shall, with his own organization, perform at least forty percent (40%) of the total dollar amount of the Work to be performed under the Agreement.

**PERSONAL INVESTIGATION** - Bidders shall satisfy themselves by personal investigation, and by such other means as they may think necessary or desirable, as to the conditions affecting the proposed work and the cost. No information derived from maps, plans, specifications, or from the Engineer or City staff shall relieve the Contractor from any risk or from fulfilling all terms of the contract.

**INCONSISTENCIES** – Any inconsistency between different provisions of the plans, specifications, bid or contract, or any point requiring explanation must be inquired by the bidder, in writing, at least ten (10) days prior to the time set for opening bids. After bids are opened, the bidders shall abide by the decision of the Engineer as to such interpretation.

**ADDENDA AND INTERPRETATIONS** - No interpretations of the meaning of the plans, specifications or other contract documents will be made orally to any bidder. Prospective bidders must request such interpretation in writing as instructed in the bid package. To be considered, such request must be received by the Questions and Answers deadline as indicated in the City's online strategic sourcing platform. Material changes, if any, to the scope of services or bidding procedures will only be transmitted by written addendum. **It is the bidder's responsibility to verify if addenda have been issued in the City's online strategic sourcing platform.** Failure of any bidder to receive any such addenda or interpretation shall not relieve any bidder from any obligation under its bid as submitted. All addenda so issued shall become a part of the contract document. **Bidder** shall verify in the City's online strategic sourcing platform that it has all addenda before submitting a bid.

**LEGAL CONDITIONS** - Bidders are notified to familiarize themselves with the provisions of the laws of the State of Florida relating to hours of labor on municipal work, and with the provisions of the laws of the State of Florida and the Charter and the ordinances of the City of Fort Lauderdale.

**PUBLIC ENTITY CRIMES** - A person or affiliate who has been placed on the convicted vendor list following a conviction for a public entity crime may not submit a bid on a contract to provide any goods or services to a public entity, may not submit a bid on a contract with a public entity for the construction or repair of a public building or public work, may not submit bids on leases of real property to a public entity, may not be awarded or perform work as a contractor, supplier, subcontractor, or consultant under a contract with any public entity, and may not transact business with any public entity in excess of the threshold amount provided in Section 287.017, Florida Statutes, for Category Two for a period of thirty-six (36) months from the date of being placed on the convicted vendor list.

**FORMS OF BIDS** - Each bid and its accompanying statements **MUST BE SUBMITTED ELECTRONICALLY, IN GOOD ORDER WITH ALL BLANKS COMPLETED,** and must show the name of the bidder and a statement as to its contents. In the event of any conflict or discrepancy between bid

price(s) submitted by bidder electronically into the City's online strategic sourcing platform Unit Price field(s), any other forms or attachments (whether part of the City's solicitation documents or documents created and uploaded by the bidder, or another section/field of the System, the online unit price(s) **inputted** electronically into the System by the bidder shall govern.

The bid must be signed by one duly authorized to do so, and in case signed by a deputy or subordinate, the principal's properly written authority to such deputy or subordinate must accompany the bid. No bid will be accepted, for any reason whatsoever, which is not submitted to the City as stated above, within the specified time.

**INSURANCE** - Contractor shall provide and shall require all of its sub-contractors to provide, pay for, and maintain in force at all times during the term of the Agreement, such insurance, including Property Insurance (Builder's Risk), Commercial General Liability Insurance, Business Automobile Liability Insurance, Workers' Compensation Insurance, Employer's Liability Insurance, and Umbrella/Excess Liability, as stated below. Such policy or policies shall be issued by companies authorized to do business in the State of Florida and having agents upon whom service of process may be made in the State of Florida.

**BID BOND** - A certified check, cashier's check or bank officer's check made payable to the City of Fort Lauderdale, or a bid bond in favor of the City of Fort Lauderdale shall accompany each bid as evidence of the good faith and responsibility of the bidder. The amount of the check or bond shall be retained by the City as liquidated damages in the event the bidder whose bid is accepted refuses to or fails to enter into a contract for the execution of the work solicited in this Invitation to Bid.

The bid bond or check shall be a guarantee that the successful bidder will promptly execute a contract satisfactory to the City for the work solicited in this Invitation to Bid and furnish good and sufficient bonds.

Following the full execution of a contract for the work solicited in this Invitation to Bid and the successful bidder's provision of good and sufficient bonds, in the event bid security was provided by check, the amount of the bid security accompanying the successful bidder's bid will be refunded to the successful bidder, or in the event bid security was provided by a bond, the bond accompanying the successful bidder's bid will be returned to the successful bidder. In the event the successful bidder fails to enter into, execute, and deliver a contract and furnish the required bonds within ten (10) days after the City provides notice to the successful bidder to deliver the executed contract and the required bonds, the bid bond shall immediately be payable to the City of Fort Lauderdale, or in the case of a check, the City shall retain the amount of the check, as liquidated damages. The City's retention of such amount shall not be construed as a penalty or forfeiture.

**FILLING IN BIDS** - All prices must be electronically submitted in the bid pages, and bids must fully cover all items for which prices are asked and no other. Where more than one person is interested, it is required that all persons interested or their legal representative make all verification and subscribe to the bid. In the event of any conflict or discrepancy between bid price(s) submitted by bidder electronically into the City's online strategic sourcing platform Unit Price field(s), any other forms or attachments (whether part of the City's solicitation documents or documents created and uploaded by the bidder, or another section/field of the System, the online unit price(s) **inputted** electronically into the System by the bidder shall govern.

**PRICES QUOTED:** Deduct any discount offered and quote firm net unit prices. In the case of a discrepancy in computing the amount of the bid, the unit price quoted will govern. All prices quoted shall be F.O.B. destination, freight prepaid (Bidder pays and bears freight charges, Bidder owns goods in transit and files any claims), unless otherwise stated in Special Conditions. Each item must be bid

separately. No attempt shall be made to tie any item or items contained in the ITB with any other business with the City.

**BIDS FIRM FOR ACCEPTANCE:** Bidder warrants, by virtue of bidding, that his bid and the prices quoted in his bid will be firm for acceptance by the City for a period of one hundred and twenty (120) days from the date of bid opening unless otherwise stated in the ITB. The City shall award contract within this time period or shall request to the recommended awarded vendor an extension to hold pricing, until products/services have been awarded.

**ADDITIONAL ITEMS OR SERVICES:** The City may require additional items or services of a similar nature, but not specifically listed in the contract. The Contractor agrees to provide such items or services and shall provide the City prices on such additional items or services. If the price(s) offered are not acceptable to the City, and the situation cannot be resolved to the satisfaction of the City, the City reserves the right to procure those items or services from other vendors, or to cancel the contract upon giving the Contractor thirty (30) days written notice.

**DELETION OR MODIFICATION OF SERVICES:** The City reserves the right to delete any portion of the Contract at any time without cause, and if such right is exercised by the City, the total fee shall be reduced in the same ratio as the estimated cost of the work deleted bears to the estimated cost of the work originally planned. If work has already been accomplished on the portion of the Contract to be deleted, the Contractor shall be paid for the deleted portion on the basis of the estimated percentage of completion of such portion.

If the Contractor and the City agree on modifications or revisions to the task elements, after the City has approved work to begin on a particular task or project, and a budget has been established for that task or project, the Contractor will submit a revised cost to the City for approval prior to proceeding with the work.

**TERMINATION FOR UNAPPROPRIATED FUNDS:** The obligation of the City for payment to a Contractor is limited to the availability of funds appropriated in a current fiscal period, and continuation of the contract into a subsequent fiscal period is subject to appropriation of funds, unless otherwise authorized by law.

**CAUSES FOR REJECTION** - No bid will be canvassed, considered or accepted which, in the opinion of the City is informal or unbalanced, or contains inadequate or unreasonable prices for any items. Each item must carry its own proportion of the cost as nearly as is practicable. Any alteration, erasure, interlineation, or failure to specify bids for all items called for in the schedule shall render the bid informal.

**REJECTION OF BIDS** - The City reserves the right to reject any bid if the evidence submitted by the bidder, or if the investigation of such bidder, fails to satisfy the City that such bidder is properly qualified to carry out the obligations and to complete the work contemplated. Any or all bids will be rejected, if there is reason to believe that collusion exists among bidders. A bid will be considered irregular and may be rejected, if it shows serious omissions, alterations in form, additions not called for, conditions or unauthorized alternates, or irregularities of any kind. The City reserves the right to reject any or all bids and to waive such technical errors as may be deemed best for the interests of the City.

**BID PROTEST PROCEDURE:** Any bidder who is not recommended for award of a contract and who alleges a failure by the City to follow the City's procurement ordinance or any applicable law may protest to the Procurement Division – Deputy Director of Finance, by delivering a letter of protest within five (5) days after a Notice of Intent to award is posted on the City's website at the following link: <https://www.fortlauderdale.gov/government/departments-a-h/finance/procurement-services/notices-of-intent-to-award>

The complete protest ordinance may be found on the City's website at the following link:  
[https://library.municode.com/fl/fort\\_lauderdale/codes/code\\_of\\_ordinances?nodeId=COOR\\_CH2AD\\_A  
RTVFI\\_DIV2PR\\_S2-182DIREPRAWINAW](https://library.municode.com/fl/fort_lauderdale/codes/code_of_ordinances?nodeId=COOR_CH2AD_ARTVFI_DIV2PR_S2-182DIREPRAWINAW)

**WITHDRAWALS** - Any bidder may, without prejudice to himself, withdraw its bid at any time prior to the expiration of the time during which bids may be submitted. Such request for withdrawal must be in writing and signed in the same manner and by the same person who signed the bid. After expiration of the period for receiving bids, no bids can be withdrawn, modified, or explained.

**CONTRACT** - The bidder to whom award is made shall execute a written contract to do the work and maintain the same in good repair until final acceptance by the proper authorities and shall furnish good and sufficient bonds as specified within ten (10) days after receiving such contract for execution. If the bidder to whom the first award is made fails to enter into a contract as provided, the award may be annulled and the contract let to the next lowest bidder who is responsive and responsible, and that bidder shall fulfill every stipulation and obligation as if such bidder were the original party to whom award was made.

The contract shall provide that the Contractor agrees to correct any defective or faulty work or material, which may appear within one (1) year after completion of the work and receipt of final payment.

**ENFORCEMENT OF SPECIFICATIONS** - Copies of the specifications will be placed in the hands of all the assistants to the Engineer and Inspectors employed on the Work, who shall enforce each and every requirement of the contract. Such assistants shall have no authority to vary from such requirements.

**DRAWING PLANS** - In order to obtain plans for the site, log into the City's online strategic sourcing platform, complete a City of Fort Lauderdale Plans Request Form, and submit it to the City in accordance with instructions contained therein.

Access to the site visit (if any) is only available to pre-approved plan-holders originating from the City of Fort Lauderdale Plans Request Form. Non-approved attendees will not be allowed to participate in the site visit. To avoid any issues, Plans Custodians should bring proof of approval to the site visit.

Pursuant to Subsection 119.071(3)(b), Florida Statutes (2022), building plans, blueprints, schematic drawings, and diagrams, including draft, preliminary, and final formats, which depict the internal layout and structural elements of the site (collectively "Plans") are exempt from public inspection and copying except to a licensed architect, engineer, or contractor who is performing work on or related to the site.

**The entities and persons receiving the Plans shall maintain the exempt status of the Plans.**

Each bidder who is not awarded the contract for construction of the project and each potential bidder who obtains the Plans ("potential bidder") agrees, at such person's or entity's expense, to return tangible Plans and any copies thereof to the City, destroy any electronic Plans obtained from the City, and certify the destruction of electronic Plans to the City in writing within fourteen days following the City Commission's award of the contract to the successful bidder. The failure by an unsuccessful bidder or potential bidder to return tangible Plans and any copies thereof to the City and destroy any electronic Plans obtained from the City and certify the destruction of electronic Plans to the City in writing within fourteen days following the City Commission's award of the contract to the successful bidder shall constitute grounds for suspension of the unsuccessful bidder's or potential bidder's right to be included on a vendor database pursuant to Section 2-183, Code of Ordinances of the City of Fort Lauderdale, Florida, and for the City to pursue any remedy at law or in equity, in which case such unsuccessful bidder or potential bidder agrees to pay the City's attorney fees and costs. The failure to maintain the exempt status of the Plans by a bidder who is not awarded the contract or by a potential bidder, shall constitute grounds for suspension of the bidder's or potential bidder's right to be included on a vendor

database pursuant to Section 2-183, Code of Ordinances of the City of Fort Lauderdale, Florida, and for the City to pursue any remedy at law or in equity, in which case such bidder or potential bidder agrees to pay the City's attorney fees and costs.

Any disclosure of the Plans by the successful bidder to any person or entity other than the City or a licensed architect, engineer, or contractor who is performing work on or related to the project shall constitute a breach of the ensuing agreement by the successful bidder and grounds for the City immediately to terminate the agreement, suspend the successful bidder's right to be included on a vendor database pursuant to Section 2-183, Code of Ordinances of the City of Fort Lauderdale, Florida, and pursue any remedy at law or in equity, in which case the successful bidder agrees to pay the City's attorney fees and costs. This paragraph shall survive the expiration or termination of the ensuing agreement between the City and the successful bidder.

**SURETY BOND** – The Contractor shall execute and record in the public records of Broward County, Florida, a payment and performance bond in an amount at least equal to the Contract Price with a surety insurer authorized to do business in the State of Florida as surety, ("Bond"), in accordance with Section 255.05, Florida Statutes (2022), as may be amended or revised, as security for the faithful performance and payment of all of the Contractor's obligations under the Contract Documents.

The successful bidder shall furnish a performance and payment bond in compliance with Section 255.05, Florida Statutes (2022), written by a Corporate Surety company, holding a Certificate of Authority from the Secretary of the Treasury of the United States as acceptable sureties on federal bonds, in an amount equal to the total amount payable by the terms of the contract, executed and issued by a Resident Agent licensed by and having an office in the State of Florida, representing such Corporate Surety, conditioned for the due and faithful performance of the work, and providing in addition to all other conditions, that if the Contractor, or his or its subcontractors, fail to duly pay for any labor, materials, or other supplies used or consumed by such Contractor, or his or its subcontractor or subcontractors, in performance of the work contracted to be done, the Surety will pay the same in the amount not exceeding the sum provided in such bonds, together with interest at the rate of fifteen percent (15%) per annum, and that they shall indemnify and hold harmless the City of Fort Lauderdale to the extent of any and all payments in connection with carrying out of the contract, which the City may be required to make under the law.

The Contractor is required at all times to have a valid surety bond in force covering the work being performed. A failure to have such bond in force at any time shall constitute a default on the part of the Contractor. A bond written by a surety, which becomes disqualified to do business in the State of Florida, shall automatically constitute a failure on the part of the Contractor to meet the above requirements.

Such bond shall continue in effect for one (1) year after completion and acceptance of the work with liability equal to at least twenty-five percent (25%) of contract price, or an additional bond shall be conditioned that the Contractor will correct any defective or faulty work or material which appear within one (1) year after completion of the contract, upon notification by the City, except in contracts which are concerned solely with demolition work, in which cases twenty-five percent (25%) liability will not be applicable.

**AUDIT OF CONTRACTOR'S RECORDS** - Upon execution of the Contract, the City reserves the right to conduct any necessary audit of the Contractor's records. Such an audit, or audits, may be conducted by the City or its representatives at any time prior to final payment, or thereafter, for a period up to three (3) years. The City may also require submittal of the records from either the Contractor, the Subcontractor, or both. For the purpose of this Section, records shall include all books of account, supporting documents and papers deemed necessary by the City to assure compliance with the contract provisions.



Failure of the Contractor or Subcontractor to comply with these requirements may result in disqualification or suspension from bidding for future contracts or disapproval as a Subcontractor at the option of the City.

The Contractor shall assure that each of its Subcontractors will provide access to its records pertaining to the project upon request by the City.

PERIODIC ESTIMATE FOR PARTIAL PAYMENT - After the Contractor has submitted a periodic estimate for partial payment, approved and certified by the Public Works Department, the City shall make payment in the manner provided in the Contract Documents and in accordance with Florida's Prompt Payment Act, Section 218, Florida Statutes (2022).

RESERVATION FOR AWARD AND REJECTION OF BIDS - The City reserves the right to accept or reject any or all bids, part of bids, and to waive minor irregularities or variations to specifications contained in bids, and minor irregularities in the bidding process. The City also reserves the right to award the contract on a split order basis, lump sum basis, individual item basis, or such combination as shall best serve the interest of the City. The City reserves the right to make an award to the responsive and responsible bidder whose product or service meets the terms, conditions, and specifications of the ITB and whose bid is considered to best serve the City's interest. In determining the responsiveness of the offer and the responsibility of the Bidder, the following shall be considered when applicable: the ability, capacity and skill of the Bidder to perform as required; whether the Bidder can perform promptly, or within the time specified, without delay or interference; the character, integrity, reputation, judgment, experience and efficiency of the Bidder; the quality of past performance by the Bidder; the previous and existing compliance by the Bidder with related laws and ordinances; the sufficiency of the Bidder's financial resources; the availability, quality and adaptability of the Bidder's supplies or services to the required use; the ability of the Bidder to provide future maintenance, service or parts; the number and scope of conditions attached to the bid.

LOCAL BUSINESS PREFERENCE – Not applicable.

DISADVANTAGED BUSINESS ENTERPRISE PREFERENCE – Not applicable.

DEBARRED OR SUSPENDED BIDDERS OR PROPOSERS - The bidder or proposer certifies, by submission of a response to this solicitation, that neither it nor its principals and subcontractors are presently debarred or suspended by any Federal department or agency.

LOBBYING ACTIVITIES - **ALL CONTRACTORS PLEASE NOTE:** Any contractor submitting a response to this solicitation must comply, if applicable, with City of Fort Lauderdale Ordinance No. C-11-42 & Resolution No. 07-101, Lobbying Activities. Copies of Ordinance No., C-11-42, and Resolution No. 07-101, may be obtained from the City Clerk's Office on the 7th Floor of City Hall, 100 N. Andrews Avenue, Fort Lauderdale, Florida 33301. The Ordinance may also be viewed on the City's website at <https://www.fortlauderdale.gov/home/showdocument?id=6036>.

**-BALANCE OF PAGE INTENTIONALLY LEFT BLANK-**

## GENERAL CONDITIONS

**Unless otherwise modified in the Project's Special Conditions, the following General Conditions shall be part of the Contract:**

**GC - 01 - DEFINITIONS** - The following words and expressions, or pronouns used in their stead, shall wherever they appear in the Contract and the Contract Documents, be construed as follows:

"Addendum" or "Addenda" - shall mean the additional Contract provisions issued in writing, by the Engineer, prior to the receipt of bids.

"Bid" – shall mean the offer or bid of the Bidder submitted on the prescribed form setting forth the prices for the Work to be performed.

"Bidder" – shall mean any person, firm, company, corporation or entity submitting a bid for the Work.

"Bonds" –shall mean bid, performance and payment bonds and other instruments of security, furnished by Contractor and his surety in accordance with the Contract Documents.

"City" – shall mean the City of Fort Lauderdale, Florida, a Florida municipal corporation. In the event the City exercises its regulatory authority as a government body, the exercise of such regulatory authority and the enforcement of any rules, regulations, codes, laws and ordinances shall be deemed to have occurred pursuant to City's authority as a governmental body and shall not be attributable in any manner to the City as a party to this Contract.

"Consultant" – shall mean a person, firm, company, corporation or other entity employed by the City to perform the professional services for the project.

"Contractor" – shall mean the successful Bidder who has been employed by the City to perform the construction and related services for the project.

"Contract Work" - shall mean everything expressed or implied to be required to be furnished and furnished by the Contractor by any one or more of the parts of the Contract Documents referred to in the Contract hereof. In the case of any inconsistency in or between any parts of this Contract, the Project Manager shall determine which shall prevail.

"Design Documents" – shall mean the construction plans and specifications included as part of a Bid Solicitation prepared either by the City or by the Consultant under a separate Agreement with the City.

"Engineer" - shall include the terms "professional engineer" and "licensed engineer" and means a person who is licensed to engage in the practice of engineering under Florida Statute, Chapter 471. An Engineer may be a City employee or a consultant hired by the City.

"Extra Work" - shall mean work other than that required by the Contract.

"Inspector" – shall mean an authorized representative of the City assigned to make necessary inspections of materials furnished by Contractor and of the Work performed by Contractor.

"Notice" - shall mean written notice sent by certified United States mail, return receipt requested, or sent by commercial express carrier with acknowledgement of delivery, or via fax or email, or by hand delivery with a request for a written receipt of acknowledgment of delivery and shall be served upon the Contractor either personally or to its place of business listed in the Bid.

"Owner" - shall mean the City of Fort Lauderdale.

"Project Manager" - shall mean a professional designated by the City to manage the Project under the supervision and direction of the Public Works Director or designee.

"Public Works Director" – shall mean the Public Works Director of the City of Fort Lauderdale.

"Site" - shall mean the area upon or in which the Contractor's operations are carried out and such other areas adjacent thereto as may be designated as such by the Project Manager.

"Sub-contractor" - shall mean any person, firm, company, corporation or other entity, other than employees of the Contractor, who or which contracts with the contractor, to furnish, or actually furnishes labor and materials, or labor and equipment, or labor, materials and equipment at the site.

"Surety" - shall mean any corporation or entity that executes, as Surety, the Contractor's performance and payment bond securing the performance of this Contract.

**GC - 02 - SITE INVESTIGATION AND REPRESENTATION** - The Contractor acknowledges that it has satisfied itself as to the nature and location of the Work under the Contract Documents, the general and local conditions of the Site, particularly those bearing upon availability of transportation, disposal, handling and storage of materials, availability of labor, water, electric power, and roads, field conditions, the type of equipment and facilities needed preliminary to and during the prosecution of the Work and all other matters which can in any way affect the Work or the cost thereof under the Contract Documents.

The Contractor acknowledges that it has conducted extensive tests, examinations and investigations and represents and warrants a thorough familiarization with the nature and extent of the Contract Documents, the Work, locality, soil conditions, moisture conditions and all year-round local weather and climate conditions (past and present), and, in reliance on such tests, examination and investigations conducted by Contractor and the Contractor's experts, has determined that no conditions exist that would in any manner affect the Bid Price and that the project can be completed for the Bid Price submitted.

Any failure by the Contractor to acquaint itself with all the Site conditions shall not relieve Contractor from responsibility for properly estimating the difficulty or cost thereof under the Contract Documents.

**GC - 03 - SUBSTITUTIONS** - If the Contractor desires to use materials and/or products of manufacturer's names different from those specified in the Contract Documents, the Bidder requesting the substitution shall make written application as described herein. The burden of proving the equality of the proposed substitution rests on the Contractor making the request. To be acceptable, the proposed substitution shall meet or exceed all expressed requirements of the Contract Documents and shall be submitted upon the Contractor's letterhead. The following requirements shall be met in order for the substitution to be considered:

1. Requests for substitution shall be accompanied by such technical data, as the party making the request desires to submit. The Project Manager will consider reports from

reputable independent testing laboratories, verified experience records from previous users and other written information valid in the circumstances; and

2. Requests for substitution shall completely and clearly indicate in what respects the materials and/or products differ from those indicated in the Contract Documents; and
3. Requests for substitution shall be accompanied by the manufacturer's printed recommendations clearly describing the installation, use and care, as applicable, of the proposed substitutions; and
4. Requests for substitution shall be accompanied by a complete schedule of changes in the Contract Documents, if any, which must be made to permit the use of the proposed substitution.

If a proposed substitution is approved by the Project Manager, an addendum will be issued to prospective bidders not less than three (3) working days prior to the date set for opening of bids. Unless substitutions are received and approved as described above, the successful Bidder shall be responsible for furnishing materials and products in strict accordance with the Contract Documents.

**GC- 04 – CONSTRUCTION RESOURCES** – Contractor shall provide all labor and equipment necessary to complete the installation within a timely manner. Contractor shall provide details as to manpower and equipment to be dedicated to the project in its Work Plan. Contractor is responsible for making arrangements, obtaining and purchasing construction water services if required to complete the work.

**GC - 05 - CONTROL OF THE WORK** - The Project Manager shall have full control and direction of the Work in all respects. The Project Manager and/or his authorized designee(s) shall, at all times, have the right to inspect the Work and materials. The Contractor shall furnish all reasonable facilities for obtaining such information, as the Project Manager may desire respecting the quality of the Work and materials and the manner of conducting the Work. Should the Contractor be permitted to perform night Work, or to vary the period which work is ordinarily carried on in the daytime, he shall give ample notice to the Project Manager so that proper and adequate inspection may be provided. Such Work shall be done only under such regulations as are furnished in writing by the Project Manager, and no extra compensation shall be allowed to the Contractor therefore. In the event of night work, the Contractor shall furnish such light, satisfactory to the Project Manager, as will ensure proper inspection. Nothing herein contained shall relieve the Contractor from compliance with any and all City ordinances relating to noise or Work during prohibited hours.

**GC - 06 - SUB-CONTRACTOR** - The Contractor shall not sublet, in whole or any part of the Work without the written consent and approval of the Project Manager. Within ten (10) days after official notification of starting date, the Contractor must submit in writing, to the Project Manager, a list of all Sub-contractors. No Work shall be done by any sub-contractor until such Sub-contractor has been officially approved by the Project Manager. A sub-contractor not appearing on the original list will not be approved without written request submitted to the Project Manager and approved by the Public Works Director. In all cases, the Contractor shall give his personal attention to the Work of the Sub-contractors and the Sub-contractor is liable to be discharged by the Contractor, at the direction of the Project Manager, for neglect of duty, incompetence or misconduct.

Acceptance of any sub-contractor, other person, or organization by the Project Manager shall not constitute a waiver of any right of Project Manager to reject defective Work or Work not in conformance with the Contract Documents.

Contractor shall be fully responsible for all acts and omissions of its Sub-contractors and of persons and organizations directly or indirectly employed by them and of persons and organizations for whose acts any of them may be liable to the same extent that he is responsible for the acts and omissions of persons directly employed by him. Nothing in the Contract Documents shall create any contractual relationship between City and any sub-contractor or other person or organization having a direct contract with Contractor, nor shall it create any obligation on the part of City to pay or to see to the payment of any moneys due to any sub-contractor or other person, or organization, except as may otherwise be required by law.

**GC - 07 - QUANTITIES** - Contractor recognizes and agrees that the quantities shown on plans and Bid/Price Schedule are estimates only and may vary during actual construction. No change shall be made involving any departure from the general scheme of the Work and that no such change involving a material change in cost, either to the City or Contractor, shall be made, except upon written permission of the City. However, the Project Manager shall have the right to make minor alternations in the line, grade, plan, form or materials of the Work herein contemplated any time before the completion of the same. That if such alterations shall diminish the quantity of the Work to be done, such alterations shall not constitute a claim for damages or anticipated profits. That if such alterations increase the amount of the Work to be done, such increase shall be paid for according to the quantity actually performed and at the unit price or prices stipulated therefore in the Contract. The City shall, in all cases of dispute, determine the amount or quantity of the several kinds of Work which are to be paid for under this Contract, and shall decide all questions relative to the execution of the same, and such estimates and decisions shall be final and binding.

Any Work not herein specified, which might be fairly implied as included in the Contract, of which the City shall judge, shall be done by the Contractor without extra charge. However, such cost increases shall be authorized either by the Public Works Director or designee, or the City Commission based upon the purchasing threshold amounts provided for in Chapter 2 of the City of Fort Lauderdale's Code of Ordinances.

**GC - 08 - NO ORAL CHANGES** - Except to the extent expressly set forth in the Contract, no change in, or modification, termination or discharge of the Contract in any form whatsoever, shall be valid or enforceable unless it is in writing and signed by the parties charged, therewith or their duly authorized representative.

**GC - 09 - PERMITS AND PROTECTION OF PUBLIC** – Permits on file with the City and/or those permits to be obtained by the Contractor, shall be considered directive in nature, and will be considered a part of this Contract. A copy of all permits shall be given to the City and become part of the Contract Documents. Terms of permits shall be met prior to acceptance of the Work and release of the final payment.

Contractor shall secure all permits and licenses required for completing the Project. Contractor will obtain the necessary State, County, and City construction/work permits if required.

The Contractor shall comply with all applicable Codes, Standards, Specifications, etc. related to all aspects of the Project.

Where there are telephones, light or power poles, water mains, conduits, pipes or drains or other construction, either public or private, in or on the streets or alleys, the Work shall be so conducted that no interruption or delay will be caused in the operation or use of the same. Proper written notice shall be given to all affected parties prior to proceeding with the Work.

The Contractor shall not be permitted to interfere with public travel and convenience by grading or tearing up streets indiscriminately, but the Work of constructing the various items in this contract shall proceed in an orderly, systematic and progressive manner.

**GC - 10 - DISEASE REGULATIONS** - The Contractor shall enforce all sanitary regulations and take all precautions against infectious diseases as the Project Manager may deem necessary. Should any infectious or contagious diseases occur among his employees, he shall arrange for the immediate removal of the employee from the Site and isolation of all persons connected with the Work.

**GC - 11 - CONTRACTOR TO CHECK PLANS, SPECIFICATIONS, AND DATA** - The Contractor shall verify all dimensions, quantities, and details shown on the plans, supplementary drawings, schedules, and shall notify the Project Manager of all errors, omissions, conflicts and discrepancies found therein within three (3) working days of discovery. Failure to discover or correct errors, conflicts, or discrepancies shall not relieve the Contractor of full responsibility for unsatisfactory Work, faulty construction, or improper operation resulting therefrom nor from rectifying such condition at its own expense.

**GC - 12 - MATERIALS AND WORKMANSHIP** - All material shall be new and the workmanship shall, in every respect, be in conformity with approved modern practice and with prevailing standards of performance and quality. In the event of a dispute, the Project Manager's decision shall be final. Wherever the Plans, Specifications, Contract Documents, or the directions of the Project Manager are unclear as to what is permissible and/or fail to note the quality of any Work, that interpretation will be made by the Project Manager, which is in accordance with approved modern practice, to meet the particular requirements of the Contract.

**GC - 13 - SAFEGUARDING MARKS** - The Contractor shall safeguard all points, stakes, grade marks, monuments, and benchmarks made or established on the Work, bear the cost of re-establishing same if disturbed, or bear the entire expense of rectifying Work improperly installed due to not maintaining or protecting or for removing without authorization, such established points, stakes and marks. The Contractor shall safeguard all existing and known property corners, monuments and marks not related to the Work and, if required, shall bear the cost of having them re-established by a licensed Professional surveyor registered in the State of Florida if disturbed or destroyed during the course of construction.

**GC - 14 - RESTROOM FACILITIES** - Contractor shall provide portable toilet facilities for employee's use at a location within the Work site to be determined by the City.

**GC - 15 - PROGRESS MEETINGS** - Weekly Status meetings will be conducted with representatives from the City and the Contractor. Contractor shall budget time to participate in such meetings. A well-run Project should result in short meetings.

**GC - 16 - ISSUE RESOLUTION** - Should Contractor become engaged in a dispute with a resident or a City employee, the Contractor shall report the situation to the Project Manager immediately. It shall be mandatory that the City participate in any dispute resolution. Failure of Contractor personnel to notify the City shall obligate Contractor to replace the offending employee immediately if requested by the City.

**GC - 17 - CITY SECURITY-CONTRACTOR AND SUBCONTRACTOR EMPLOYEE INFORMATION** - Prior to commencing work, Contractor shall provide to the City a list of all personnel and subcontractors on site. The list will include the name, address, birth date and driver's license number for all personnel. All personnel and subcontractors on site will have on their person a company

photo ID during all stages of the construction. Contractor shall provide standard required personal information per current City procedures.

**GC - 18 - POST-CONSTRUCTION SURVEY** - The Contractor shall provide as-built survey, sealed and signed by a registered surveyor in the State of Florida, as a condition of final payment.

**GC - 19 - KEY PERSONNEL** - Contractor shall provide as part of the Work Plan, resumes for all key project personnel providing supervision and project management functions. Resumes shall include work history and years of experience performing this type of work.

**GC - 20 - EXISTING UTILITY SERVICE** - All existing utility service shall be maintained with a minimum of interruption at the expense of the Contractor.

**GC - 21 - JOB DESCRIPTION SIGNS** – Contractor, at Contractor’s expense, shall furnish, erect, and maintain suitable weatherproof signs on jobs over \$100,000 containing the following information:

1. City Seal (in colors)
2. Project or Improvement Number
3. Job Description
4. Estimated Cost
5. Completion Date

Minimum size of sign shall be four feet high, eight feet wide and shall be suitably anchored. The entire sign shall be painted and present a pleasing appearance. Exact location of signs will be determined in the field. Two (2) signs will be required, one at each end of the job. All costs of this work shall be included in other parts of the work.

**GC - 22 - FLORIDA EAST COAST RIGHT-OF-WAY** - Whenever a City contractor is constructing within the Florida East Coast Railway Company's Right-of-Way, it will be mandatory that the contractor carry bodily injury and property damage insurance in amounts satisfactory to the Florida East Coast Company. This insurance requirement shall be verified by the contractor with the Florida East Coast Company prior to commencing work, and maintained during the life of the Contract.

**GC - 23 - ACCIDENTS** - The Contractor shall provide such equipment and facilities as are necessary and/or required, in the case of accidents, for first aide services to be provided to a person who may be injured during the project duration. The Contractor shall also comply with the OSHA requirements as defined in the United States Labor Code 29 CFR 1926.50.

In addition, the Contractor must report immediately to the Project Manager every accident to persons or damage to property, and shall furnish in writing full information, including testimony of witnesses regarding any and all accidents.

**GC - 24 - SAFETY PRECAUTIONS** - Contractor must adhere to the applicable environmental protection guidelines for the duration of a project. If hazardous waste materials are used, detected or generated at any time, the Project Manager must be immediately notified of each and every occurrence. The Contractor shall comply with all codes, ordinances, rules, orders and other legal requirements of public authorities (including OSHA, EPA, DERM, the City, Broward County, State of Florida, and Florida Building Code), which bear on the performance of the Work.

The Contractor shall take the responsibility to ensure that all Work is performed using adequate safeguards, including but not limited to: proper safe rigging, safety nets, fencing, scaffolding, barricades, chain link fencing, railings, barricades, steel plates, safety lights, and ladders that are

necessary for the protection of its employees, as well as the public and City employees. All riggings and scaffolding shall be constructed with good sound materials, of adequate dimensions for their intended use, and substantially braced, tied or secured to ensure absolute safety for those required to use it, as well as those in the vicinity. All riggings, scaffolding, platforms, equipment guards, trenching, shoring, ladders and similar actions or equipment shall be OSHA approved, as applicable, and in accordance with all Federal, State and local regulations.

**GC - 25 - DUST PREVENTION** - The Contractor shall, by means of a water spray, or temporary asphalt pavement, take all necessary precautions to prevent or abate a dust nuisance arising from dry weather or Work in an incomplete stage. All costs of this Work shall be included in the cost of other parts of the Work.

Should the Contractor fail to abate a dust nuisance the Project Manager may stop the Work until the issue is resolved to the City's satisfaction.

**GC - 26 - SITE CLEANUP AND RESTORATION** – The Contractor shall remove all debris and unused or discarded materials from the work site daily. Contractor shall clean the work site to remove all directional drilling "Driller's Mud" materials. No "Driller's Mud" residue shall be allowed to remain in the soil or on the surface of the land or vegetation. All debris and drilling materials must be disposed of offsite at an approved location.

The Contractor shall promptly restore all areas disturbed that are outside the Project limits in equal or better condition at no additional cost to the City.

**GC - 27 - COURTEOUS BEHAVIOR AND RESPECT FOR RESIDENTS AND PROPERTY** – The Contractor and its employees, associates and sub-contractors shall maintain courteous behavior at all times and not engage in yelling, loud music, or other such activities. Contractor's employees shall not leave trash or other discarded items at the Work Site, especially on any private property. In the event complaints arise, Contractor shall immediately remove such offending employees from the project if requested to do so by the Project Manager. Contractor's employees shall not trespass on any private property unless necessary to complete the work but with prior permission from the owner.

Contractor shall notify and obtain permission from the residents 24 hours in advance when planning to work within the resident's property. In addition, Contractor shall notify the resident prior to entering their property to perform work or inspect/investigate the work site. Contractor shall not block residents' driveways unnecessarily. Contractor shall not park equipment on landscaped areas when the vehicle is not needed for the current construction activities. Contractor shall be responsible for repair and/or replacement of all damaged landscaping within 48 hours including repairing vehicle wheel impressions, irrigation systems, lighting systems, structures, or any other items of resident's property. Contractor shall not destroy, damage, remove, or otherwise negatively impact any landscaping within or outside the right-of-way without prior approval from the Project Manager.

**GC - 28 - PLACING BARRICADES AND WARNING LIGHTS** - The Contractor shall furnish and place, at Contractor's own expense, all barricades, warning lights, automatic blinker lights and such devices necessary to properly protect the work and vehicular and pedestrian traffic. Should the Contractor fail to erect or maintain such barricades, warning lights, etc., the Project Manager may, after 24 hours' notice to the Contractor, proceed to have such barricades and warning lights placed and maintained by City or other forces and all costs incurred thereof charged to the Contractor and may be retained by the City from any monies due, or to become due, to the Contractor.

**GC - 29 - TRAFFIC CONTROL** - The Contractor shall coordinate all Work and obtain, through the City's Transportation and Mobility Department, Broward County, Florida Department of



Transportation, as applicable, any permits required to detour traffic or close any street before starting to work in the road.

All traffic control devices, flashing lights, signs and barricades shall be maintained in working condition at all times and conform to Manual of Uniform Traffic Control Devices (MUTCD), latest edition.

**GC - 30 - COORDINATION** - The Contractor shall notify all utilities, transportation department, etc., in writing, with a copy to the Project Manager before construction is started and shall coordinate its Work with them. The Contractor shall cooperate with the owners of any underground or overhead utility lines in their removal, construction and rearrangement operations in order that services rendered by these parties will not be unnecessarily interrupted.

The Contractor shall arrange its Work and dispose of its materials so as to not interfere with the operation of other contractors engaged upon adjacent work, and to join its Work to that of others in a proper manner, and to perform its Work in the proper sequence in relation to that of other contractors as may be directed by the Project Manager.

Each Contractor shall be responsible for any damage done by it or its agents to the work performed by another contractor.

**GC - 31 - WATER** - Bulk water used for construction, flushing pipelines, and testing shall be obtained from fire hydrants. Contractor shall make payment for hydrant meter at Treasury Billing Office, 1st Floor, City Hall, 100 N. Andrews Avenue. With the paid receipt, contractor can pick up hydrant meter at the utility location office. No connection shall be made to a fire hydrant without a meter connected.

**GC - 32 - PROHIBITION AGAINST CONTRACTING WITH SCRUTINIZED COMPANIES** - Subject to *Odebrecht Construction, Inc., v. Prasad*, 876 F.Supp.2d 1305 (S.D. Fla. 2012), *affirmed*, *Odebrecht Construction, Inc., v. Secretary, Florida Department of Transportation*, 715 F.3d 1268 (11th Cir. 2013), with regard to the "Cuba Amendment," the Contractor certifies that it is not on the Scrutinized Companies with Activities in Sudan List or the Scrutinized Companies with Activities in the Iran Petroleum Energy Sector List, and that it does not have business operations in Cuba or Syria, as provided in Section 287.135, Florida Statutes (2022), as may be amended or revised. The Contractor certifies that it is not on the Scrutinized Companies that Boycott Israel List created pursuant to Section 215.4725, Florida Statutes (2022), as may be amended or revised, and that it is not engaged in a boycott of Israel. The City may terminate this Agreement at the City's option if the Contractor is found to have submitted a false certification as provided under subsection (5) of Section 287.135, Florida Statutes (2022), as may be amended or revised, or been placed on the Scrutinized Companies with Activities in Sudan List or the Scrutinized Companies with Activities in the Iran Petroleum Energy Sector List or the Scrutinized Companies that Boycott Israel List created pursuant to Section 215.4725, Florida Statutes (2022), as may be amended or revised, or is engaged in a boycott of Israel or has been engaged in business operations in Cuba or Syria, as defined in Section 287.135, Florida Statutes (2022), as may be amended or revised.

By submitting a bid or response, the company, principals, or owners certify that it is not listed on the Scrutinized Companies with Activities in Sudan List or listed on the Scrutinized Companies with Activities in the Iran Petroleum Energy Sector List or is engaged in business operations in Cuba or Syria.

**GC - 33 - USE OF FLORIDA LUMBER TIMBER AND OTHER FOREST PRODUCTS** - In accordance with Florida Statute 255.20 (3), the City specifies that lumber, timber, and other forest products used for this Project shall be produced and manufactured in the State of Florida if such products are

available and their price, fitness, and quality are equal. This requirement does not apply to plywood specified for monolithic concrete forms, if the structural or service requirements for timber for a particular job cannot be supplied by native species, or if the construction is financed in whole or in part from federal funds with the requirement that there be no restrictions as to species or place of manufacture.

The Bidder affirms by submitting a bid response to this solicitation that they will comply with section 255.20 (3) Florida Statutes.

**GC - 34 - PUBLIC RECORDS/TRADE SECRETS/COPYRIGHT:** The Proposer's response to the Solicitation is a public record pursuant to Florida law, which is subject to disclosure by the City under the State of Florida Public Records Law, Florida Statutes Chapter 119.07 ("Public Records Law"). The City shall permit public access to all documents, papers, letters or other material submitted in connection with this Solicitation and the Contract to be executed for this Solicitation, subject to the provisions of Chapter 119.07 of the Florida Statutes.

Any language contained in the Bidder's response to the Solicitation purporting to require confidentiality of any portion of the Bidder's response to the Solicitation, except to the extent that certain information is in the City's opinion a Trade Secret pursuant to Florida law, shall be void. If a Bidder submits any documents or other information to the City which the Bidder claims is Trade Secret information and exempt from Florida Statutes Chapter 119.07 ("Public Records Laws"), the Bidder shall clearly designate that it is a Trade Secret and that it is asserting that the document or information is exempt. The Bidder must specifically identify the exemption being claimed under Florida Statutes 119.07. The City shall be the final arbiter of whether any information contained in the Bidder's response to the Solicitation constitutes a Trade Secret. The City's determination of whether an exemption applies shall be final, and the bidder agrees to defend, indemnify, and hold harmless the City and the City's officers, employees, and agent, against any loss or damages incurred by any person or entity as a result of the City's treatment of records as public records. In addition, the bidder agrees to defend, indemnify, and hold harmless the City and the City's officers, employees, and agents, against any loss or damages incurred by any person or entity as a result of the City's treatment of records as exempt from disclosure or confidential. Bids purporting to be subject to copyright protection in full or in part will be rejected. The bidder authorizes the City to publish, copy, and reproduce any and all documents submitted to the City bearing copyright symbols or otherwise purporting to be subject to copyright protection.

EXCEPT FOR CLEARLY MARKED PORTIONS THAT ARE BONA FIDE TRADE SECRETS PURSUANT TO FLORIDA LAW, DO NOT MARK YOUR RESPONSE TO THE SOLICITATION AS PROPRIETARY OR CONFIDENTIAL. DO NOT MARK YOUR RESPONSE TO THE SOLICITATION OR ANY PART THEREOF AS COPYRIGHTED.

**IF THE CONTRACTOR HAS QUESTIONS REGARDING THE APPLICATION OF CHAPTER 119, FLORIDA STATUTES (2022), TO THE CONTRACTOR'S DUTY TO PROVIDE PUBLIC RECORDS RELATING TO THIS AGREEMENT, CONTACT THE CUSTODIAN OF PUBLIC RECORDS AT:**

**Telephone Number:** (954) 828-5002

**Mailing Address:** City Clerk's Office  
100 N. Andrews Avenue  
Fort Lauderdale, Florida 33301-1016

**E-mail:** [prcontract@fortlauderdale.gov](mailto:prcontract@fortlauderdale.gov)

Contractor shall:

1. Keep and maintain public records required by the City in order to perform the service.
2. Upon request from the City's custodian of public records, provide the City with a copy of the requested records or allow the records to be inspected or copied within a reasonable time at a cost that does not exceed the cost provided in Chapter 119, Florida Statutes (2022), as may be amended or revised, or as otherwise provided by law.
3. Ensure that public records that are exempt or confidential and exempt from public records disclosure requirements are not disclosed except as authorized by law for the duration of the contract term and following completion of this Agreement if the Contractor does not transfer the records to the City.
4. Upon completion of the Agreement, transfer, at no cost, to the City all public records in possession of the Contractor or keep and maintain public records required by the City to perform the service. If the Contractor transfers all public records to the City upon completion of this Agreement, the Contractor shall destroy any duplicate public records that are exempt or confidential and exempt from public records disclosure requirements. If the Contractor keeps and maintains public records upon completion of this Agreement, the Contractor shall meet all applicable requirements for retaining public records. All records stored electronically must be provided to the City, upon request from the City's custodian of public records, in a format that is compatible with the information technology systems of the City.

**-BALANCE OF PAGE INTENTIONALLY LEFT BLANK-**

## SPECIAL CONDITIONS

### 01. PURPOSE

The City of Fort Lauderdale, Florida (City) is seeking bids from qualified bidders, hereinafter referred to as the Contractor, to provide building/construction services for the City's Public Works Department, in accordance with the terms, conditions, and specifications contained in this Invitation To Bid (ITB).

This project is located at the George T. Lohmeyer Wastewater Treatment Plant (GTL WWTP), 1000 SE 21 Street, Fort Lauderdale, Florida, 33316 in the City of Fort Lauderdale. The work to be accomplished under this solicitation includes, but is not limited to, furnishing all labor, materials and equipment to perform mechanical integrity testing (MIT) of five (5) existing Class I injection wells.

The Injection Wells have a 24-inch outside diameter (OD), 0.500-inch wall thickness injection casing set to total depths of 2,800 to 2,820 feet below land surface (BLS) and were constructed with a nominal 22-inch diameter open borehole extending from the bottom of the casing to approximately 3,305 to 4,010 feet BLS. Also, this project includes the replacement of some piping and painting, and required appurtenances at each injection well.

### 02. TRANSACTION FEES

The City uses the City's online strategic sourcing platform INFOR ([www.INFOR.com](http://www.INFOR.com)) to distribute and receive bids and proposals. There is no charge to vendors/contractors to register and participate in the solicitation process, nor will any fees be charged to the awarded contractor.

### 03. SUBMISSION OF BIDS

It is the sole responsibility of the Contractor to ensure that its bid is submitted electronically through the City's online strategic sourcing platform, [www.INFOR.com](http://www.INFOR.com), and that any bid security reaches the City of Fort Lauderdale, Procurement Services Division, 521 NE 4th Avenue, Fort Lauderdale, Florida 33301-1016, in a sealed envelope marked on the outside with the ITB solicitation number and Contractor's name, no later than the time and date specified in this solicitation. **PAPER BID SUBMITTALS WILL NOT BE ACCEPTED. PLEASE SUBMIT YOUR BID RESPONSE ELECTRONICALLY.** In the event of any conflict or discrepancy between bid price(s) submitted by bidder electronically into the City's online strategic sourcing platform Unit Price field(s), any other forms or attachments (whether part of the City's solicitation documents or documents created and uploaded by the bidder, or another section/field of the System, the online unit price(s) **inputted** electronically into the System by the bidder shall govern.

### 04. INFORMATION OR CLARIFICATION

For information concerning procedures for responding to this solicitation, contact Erick Martinez, **Senior Procurement Specialist**, at (954) 828-4019 or email at [emartinez@fortlauderdale.gov](mailto:emartinez@fortlauderdale.gov). Such contact shall be for clarification purposes only.

### 05. CONTRACT TIME

5.1 The Contractor recognizes that TIME IS OF THE ESSENCE. The Work shall commence within seven (7) calendar days of the date of the Notice to Proceed.

- 5.2 The Work shall be Substantially Completed within one hundred (100) calendar days after the date when the Contract Time commences to run as provided in the Notice to Proceed.
- 5.3 The Work shall be finally completed on the Final Completion Date and ready for final payment in accordance with this Agreement within one hundred twenty (120) calendar days after the Substantial Completion date.

**06. BID SECURITY**

A certified check, cashier's check, bank officer's check or bid bond for **FIVE (5%) percent** of the bid amount, made payable to the City of Fort Lauderdale, shall accompany each offer.

**07. REQUIRED LICENSES/CERTIFICATIONS**

Contractor must possess the following licenses/certifications to be considered for award:

Geophysical Contractor holding a valid State of Florida Water Well Contractor License issued by the South Florida Water Management District is required for this Project.

**Note: Contractor must have proper licensing and shall submit evidence of same with its bid response.**

**08. SPECIFIC EXPERIENCE REQUIRED**

The following expertise is required to be considered for this Contract. Specific references attesting to this expertise must be submitted with the bid response.

The contractor shall have previous construction experience in construction/repairs of wells of at least 5 years and shall have tested not less than 5 wells of similar type and capacity. Bidder shall submit proof of construction experience for a minimum of three (3) projects of similar scope and scale (or larger) and shall, for each project listed, identify location; dates of construction; project name and overall scope; scope of work that was self-performed by Contractor; and client's name, address, telephone number and e-mail address.

**NOTE: REFERENCES SHALL NOT INCLUDE ONLY CITY OF FORT LAUDERDALE EMPLOYEES OR WORK PERFORMED FOR THE CITY. THE CITY IS ALSO INTERESTED IN WORK EXPERIENCE AND REFERENCES FROM ENTITIES OTHER THAN THE CITY OF FORT LAUDERDALE.**

***By signing this bid solicitation, contractor is affirming that this expertise will be provided for this Contract at no additional charge.***

**09. BID ALLOWANCE**

**Allowance for permits:** Payments will be made to the contractor based on the actual cost of permits upon submission of paid permit receipts. The City shall not pay for other costs related to obtaining or securing permits.

The amount indicated is intended to be sufficient to cover the entire Project. If the City's permit fees exceed the allowance indicated, the City will reimburse the contractor the actual amount of the City's permit fees required for project completion.

<b>Allowance</b>	<b>Amount</b>
Additional Equipment Rental Allowance	\$20,000
Additional Labor Allowance	\$10,000
Additional Material Allowance	\$10,000
Crane Rental Allowance	\$20,000
FPL, AT&T Allowance	\$20,000
Permit Fees & Testing Allowance	\$100,000
Owner's Contingency	\$20,000
	<b>\$200,000</b>

**10. INSURANCE REQUIREMENTS** (See Article 10, Bonds and Insurance, of the Contract for details)

As a condition precedent to the effectiveness of this Agreement, during the term of this Agreement and during any renewal or extension term of this Agreement, Contractor, at its sole expense, shall provide insurance of such types and with such terms and limits as noted below. Providing proof of and maintaining adequate insurance coverage are material obligations of Contractor. Contractor shall provide the City a certificate of insurance evidencing such coverage. Contractor's insurance coverage shall be primary insurance for all applicable policies, in respect to the City's interests. The limits of coverage under each policy maintained by Contractor shall not be interpreted as limiting Contractor's liability and obligations under this Agreement. All insurance policies shall be through insurers authorized or eligible to write policies in the State of Florida and possess an A.M. Best rating of A-, VII or better, subject to approval by the City's Risk Manager.

The coverages, limits, and/or endorsements required herein protect the interests of the City, and these coverages, limits, and/or endorsements shall in no way be relied upon by Contractor for assessing the extent or determining appropriate types and limits of coverage to protect Contractor against any loss exposures, whether as a result of this Agreement or otherwise. The requirements contained herein, as well as the City's review or acknowledgement, are not intended to and shall not in any manner limit or qualify the liabilities and obligations assumed by Contractor under this Agreement.

The following insurance policies and coverages are required:

Commercial General Liability

Coverage must be afforded under a Commercial General Liability policy with limits not less than:

- \$1,000,000 each occurrence and \$2,000,000 aggregate for Bodily Injury, Property Damage, and Personal and Advertising Injury
- \$1,000,000 each occurrence and \$2,000,000 aggregate for Products and Completed Operations

Policy must include coverage for contractual liability and independent contractors.

The City, a Florida municipality, its officials, employees, and volunteers are to be covered as an additional insured with a CG 20 26 04 13 Additional Insured – Designated Person or Organization Endorsement or similar endorsement providing equal or broader Additional Insured Coverage with respect to liability arising out of activities performed by or on behalf of Contractor. The coverage shall contain no special limitation on the scope of protection afforded to the City, its officials, employees, and volunteers.

#### Crane and Rigging Liability

Coverage must be afforded for any crane operations under the Commercial General or Business Automobile Liability policy as necessary, in line with the limits of the associated policy.

#### Business Automobile Liability

Coverage must be afforded for all Owned, Hired, Scheduled, and Non-Owned vehicles for Bodily Injury and Property Damage in an amount not less than \$1,000,000 combined single limit each accident.

If Contractor does not own vehicles, Contractor shall maintain coverage for Hired and Non-Owned Auto Liability, which may be satisfied by way of endorsement to the Commercial General Liability policy or separate Business Auto Liability policy.

#### Workers' Compensation and Employer's Liability

Coverage must be afforded per Chapter 440, Florida Statutes. Any person or entity performing work for or on behalf of the City must provide Workers' Compensation insurance. Exceptions and exemptions will be allowed by the City's Risk Manager, if they are in accordance with Florida Statute.

Contractor waives, and Contractor shall ensure that Contractor's insurance carrier waives, all subrogation rights against the City, its officials, employees, and volunteers for all losses or damages. The City requires the policy to be endorsed with WC 00 03 13 Waiver of our Right to Recover from Others or equivalent.

Contractor must be in compliance with all applicable State and Federal workers' compensation laws, including the U.S. Longshore and Harbor Workers' Compensation Act and the Jones Act, if applicable.

#### Insurance Certificate Requirements

- a. Contractor shall provide the City with valid Certificates of Insurance (binders are unacceptable) no later than ten (10) days prior to the start of work contemplated in this Agreement.
- b. Contractor shall provide to the City a Certificate of Insurance having a thirty (30) day notice of cancellation; ten (10) days' notice if cancellation is for nonpayment of premium.
- c. In the event that the insurer is unable to accommodate the cancellation notice requirement, it shall be the responsibility of Contractor to provide the proper notice. Such notification will be in writing by registered mail, return receipt requested, and addressed to the certificate holder.
- d. In the event the Agreement term or any surviving obligation of Contractor following expiration or early termination of the Agreement goes beyond the expiration date of the insurance policy, Contractor shall provide the City with an updated Certificate of Insurance no later than ten (10) days prior to the expiration of the insurance currently

in effect. The City reserves the right to suspend the Agreement until this requirement is met.

- e. The Certificate of Insurance shall indicate whether coverage is provided under a claims-made or occurrence form. If any coverage is provided on a claims-made form, the Certificate of Insurance must show a retroactive date, which shall be the effective date of the initial contract or prior.
- f. The City shall be covered as an Additional Insured on all liability policies, with the exception of Workers' Compensation.
- g. The City shall be granted a Waiver of Subrogation on Contractor's Workers' Compensation insurance policy.
- h. The title of the Agreement, Bid/Contract number, event dates, or other identifying reference must be listed on the Certificate of Insurance.

The Certificate Holder should read as follows:

City of Fort Lauderdale  
100 N. Andrews Avenue  
Fort Lauderdale, FL 33301

Contractor has the sole responsibility for all insurance premiums and shall be fully and solely responsible for any costs or expenses as a result of a coverage deductible, co-insurance penalty, or self-insured retention; including any loss not covered because of the application of such deductible, co-insurance penalty, self-insured retention, or coverage exclusion or limitation. Any costs for adding the City as an Additional Insured shall be at Contractor's expense.

If Contractor's primary insurance policy/policies do not meet the minimum requirements as set forth in this Agreement, Contractor may provide evidence of an Umbrella/Excess insurance policy to comply with this requirement.

Contractor's insurance coverage shall be primary insurance in respect to the City's interests, a Florida municipality, its officials, employees, and volunteers. Any insurance or self-insurance maintained by the City shall be non-contributory.

Any exclusion or provision in any insurance policy maintained by Contractor that excludes coverage required in this Agreement shall be deemed unacceptable and shall be considered breach of contract.

All required insurance policies must be maintained until the Agreement work has been accepted by the City, or until this Agreement is terminated, whichever is later. Any lapse in coverage may be considered breach of contract. In addition, Contractor must provide to the City confirmation of coverage renewal via an updated certificate of insurance should any policies expire prior to the expiration of this Agreement. The City reserves the right to review, at any time, coverage forms and limits of Contractor's insurance policies.

Contractor shall provide notice of any and all claims, accidents, and any other occurrences associated with this Agreement to Contractor's insurance company or companies and the City's Risk Management office as soon as practical.

It is Contractor's responsibility to ensure that any and all of Contractor's independent contractors and subcontractors comply with these insurance requirements. All coverages for independent contractors and subcontractors shall be subject to all of the applicable requirements stated



herein. Any and all deficiencies are the responsibility of Contractor. The City reserves the right to adjust insurance limits from time to time at its discretion with notice to Contractor.

**NOTE: CITY PROJECT NUMBER, PROJECT NAME AND BID NUMBER MUST APPEAR ON EACH CERTIFICATE, AND THE CITY OF FORT LAUDERDALE MUST BE NAMED ON THE CERTIFICATE AS AN “ADDITIONAL INSURED” ON REQUIRED LIABILITY POLICIES.**

A Sample Insurance Certificate shall be included with the bid to demonstrate the firm’s ability to comply with insurance requirements. Provide a previous certificate or other evidence listing the insurance companies’ names for all required coverage, and the dollar amounts of the coverage.

11. **PERFORMANCE AND PAYMENT BOND:** 100%

12. **CITY PROJECT MANAGER**

The Project Manager is hereby designated by the City as Justin Murray, P.E. whose address is 1765 SE 18th Street, Administration Building Main Floor, Fort Lauderdale, FL 33316, telephone number: (954) 828-4122, and e-mail address is [jmurray@fortlauderdale.gov](mailto:jmurray@fortlauderdale.gov). The Project Manager will assume all duties and responsibilities and will have the rights and authorities assigned to the Project Manager in the Contract Documents in connection with completion of the Work in accordance with this Agreement.

13. **LIQUIDATED DAMAGES** (See Article 16, Liquidated Damages, of the Contract for details)

Upon failure of the Contractor to complete the Work within the time specified for completion, the Contractor shall pay to the City the sum of **One Thousand Dollars (\$1,000.00)** for each and every calendar day that the completion of the Work is delayed beyond the time specified in this Agreement for completion, as fixed and agreed liquidated damages and not as a penalty, so long as the delay is caused by the Contractor. (See Article 16, Liquidated Damages Clause, of the Contract)

14. **PAYMENT** (See Article 7, Payment, of the Contract for other details)

The City shall make payment to the Contractor through utilization of the City’s P-Card Program. The City has implemented a Purchasing Card (P-Card) Program utilizing both the VISA and MASTERCARD networks. Purchases from this contract will be made utilizing the City’s Purchasing Card. Contractor will receive payment from the purchasing card in the same manner as other credit card purchases. Accordingly, Contractor must presently have the ability to accept these credit cards or take whatever steps necessary to implement the ability before the start of the contract term, or contract award by the City. All costs associated with the Contractor’s participation in this purchasing program shall be borne by the Contractor. The City reserves the right to revise this program as necessary.

Payment Card Industry (PCI) Compliance

Contractor agrees to comply with all applicable state, federal and international laws, as well as industry best practices, governing the collection, access, use, disclosure, safeguarding and destruction of Protected Information.

Contractor and/or any subcontractor that handles credit card data must be, and remain, PCI compliant under the current standards and will provide documentation confirming compliance upon request by the City of Fort Lauderdale, failure to produce documentation could result in termination of the contract.

**15. WORK SCHEDULE (including overtime hours):**

Regular work hours: **8:00 am to 5:00 pm, Monday through Friday.**

City Inspector Hours: **8:00 am to 4:30 pm, Monday through Friday.**

Any inspection requested by the contractor outside those hours will be considered overtime to be paid by the Contractor.

**16. INSPECTION OVERTIME COST: \$100/hr.**

CITY OF FORT LAUDERDALE  
CONSTRUCTION AGREEMENT

THIS Agreement made and entered into this \_\_\_\_\_ day of \_\_\_\_\_, 20\_\_\_\_, by and between the City of Fort Lauderdale, a Florida municipal corporation ("City") and \_\_\_\_\_, a Florida company/corporation ("Contractor"), ("Party" or collectively "Parties");

WHEREAS, the City desires to retain a contractor for the Project as expressed in its Event/Invitation to Bid No. 191, Project Number P12798, which was opened on \_\_\_\_\_; and

WHEREAS, the Contractor has expressed its willingness and capability to perform the necessary work to accomplish the Project;

NOW, THEREFORE, the City and the Contractor, in consideration of the mutual covenants and conditions contained herein and for other good and valuable consideration, the receipt and sufficiency is hereby acknowledged, agree as follows:

**ARTICLE 1 – DEFINITIONS**

Whenever used in this Agreement or in other Contract Documents, the following terms have the meanings indicated which are applicable to both the singular and plural forms:

- 1.1 Agreement – This written Agreement between the City and the Contractor covering the work to be performed including other Contract Documents that are attached to or incorporated in the Agreement.
- 1.2 Application for Payment – The form accepted by the City which is to be used by the Contractor in requesting progress or final payment and which is to include such supporting documentation as is required by the Contract Documents.
- 1.3 Approve – The word approve is defined to mean review of the material, equipment or methods for general compliance with design concepts and with the information given in the Contract Documents. It does not imply a responsibility on the part of the City to verify in every detail conformance with plans and specifications.
- 1.4 Bid – The offer or Bid of the Contractor submitted on the prescribed form setting forth the total prices for the Work to be performed.
- 1.5 Bid Documents – Advertisement for Invitation to Bids, the Instructions to Bidders, the Bid Form (with supplemental affidavits and sample agreements), the Contract Forms, General Conditions, the Supplementary Conditions, the Specifications, and the Plans, which documents all become an integral part of the Contract Documents.
- 1.6 Certificate of Substantial Completion - Certificate provided by the City certifying that all Work, excluding the punch list items, has been completed, inspected, and accepted by the City.

- 1.7 Change Order - A written document executed by both Parties ordering a change in the Contract Price or Contract Time or a material change in the Work.
- 1.8 City – The City of Fort Lauderdale, Florida, including but not limited to its employees, agents, officials, representatives, contractors, subcontractors, volunteers, successors and assigns, with whom the Contractor has entered into the Agreement and for whom the Work is to be provided.
- 1.9 Contract Documents – The Contract Documents shall consist of this Agreement, Exhibits to this Agreement, Public Construction Bond, Performance Bond, Payment Bond and Certificates of Insurance, Notice of Award and Notice to Proceed, General Conditions, Special Conditions, Technical Specifications, Plans/Drawings, Addenda, Bid Form and supplement Affidavits and Agreements, all applicable provisions of State and Federal Law and any modification, including Change Orders or written amendments duly delivered after execution of Agreement, Invitation to Bid, Instructions to Bidders and Bid Bond, Contractor’s response to the City’s Invitation to Bid, Schedule of Completion, Schedule of Values, all amendments, modifications and supplements, work directive changes issued on or after the Effective Date of the Agreement, as well as any additional documents that are required to be submitted under the Agreement.

Permits on file with the City and/or those permits to be obtained shall be considered directive in nature and will be considered a part of this Agreement. A copy of all permits shall be given to the City for inclusion in the Contract Documents. Terms of permits shall be met prior to acceptance of the Work and release of the final payment.

- 1.10 Contract Price – The amount established in the bid submittal and award by the City’s City Commission, as may be amended by Change Order.
- 1.11 Contract Time – The number of calendar days stated in the Agreement for the completion of the Work. The dates on which the work shall be started and shall be completed as stated in the Notice to Proceed.
- 1.12 Contractor – The person, firm, company, or corporation with whom the City has entered into the Agreement, including but not limited to its employees, agents, representatives, contractors, subcontractors, their subcontractors and their other successors and assigns.
- 1.13 Day – A calendar day of twenty-four (24) hours ending at midnight.
- 1.14 Defective – When modifying the word “Work” refers to work that is unsatisfactory, faulty, or deficient, or does not conform to the Contract Documents or does not meet the requirements of any inspection, test or approval referred to in the Contract Documents, or has been damaged prior to the Project Manager’s recommendation of final payment.
- 1.15 Effective Date of the Agreement – The effective date of the Agreement shall be the date the City Commission approves the work.

- 1.16 Final Completion Date – The date the Work is completed, including completion of the final punch list, and delivered along with those items specified in the Contract Documents and is accepted by the City.
- 1.17 Hazardous Materials (HAZMAT) - Any solid, liquid, or gaseous material that is toxic, flammable, radioactive, corrosive, chemically reactive, or unstable upon prolonged storage in quantities that could pose a threat to life, property, or the environment defined in Section 101(14) of Comprehensive Environmental Response, Compensation and Liability Act of 1980 and in 40 CFR 300.6. Also defined by 49 CFR 171.8 as a substance or material designated by the Secretary of Transportation to be capable of posing an unreasonable risk to health, safety, and property when transported in commerce and which has been so designated.
- 1.18 Hazardous Substance - As defined by Section 101(14) of the Comprehensive Environmental Response, Compensation and Liability Act; any substance designated pursuant to Section 311(b) (2) (A) of the Clean Water Act; any element, compound, mixture, solution or substance designated pursuant to Section 102 identified under or listed pursuant to Section 3001 of the Solid Waste Disposal Act {but not including any waste listed under Section 307[a] of the Clean Water Act}; any hazardous air pollutant listed under Section 112 of the Clean Air Act; and any imminently hazardous chemical substance or mixture pursuant to Section 7 of the Toxic Substances Control Act. The term does not include petroleum, including crude oil or any fraction thereof, which is not otherwise specifically listed or designated as a hazardous substance in the first sentence of this paragraph, and the term does not include natural gas, natural gas liquids, liquefied natural gas, or synthetic gas usable for fuel (or mixtures of natural gas and such synthetic gas).
- 1.19 Hazardous Waste - Those solid wastes designated by OSHA in accordance with 40 CFR 261 due to the properties of ignitability, corrosivity, reactivity, or toxicity. Any material that is subject to the Hazardous Waste Manifest requirements of the EPA specified in 40 CFR Part 262.
- 1.20 Holidays - Those designated non-workdays as established by the City Commission of the City of Fort Lauderdale.
- 1.21 Inspection – The term “inspection” and the act of inspecting as used in this Agreement is defined to mean the examination of construction to ensure that it conforms to the design concept expressed in the plans and specifications. This term shall not be construed to mean supervision, superintending and/or overseeing.
- 1.22 Notice of Award - The written notice by City to the Contractor stating that upon compliance by the Contractor with the condition’s precedent enumerated therein, within the time specified that the City will sign and deliver this Agreement.
- 1.23 Notice to Proceed – A written notice to Contractor authorizing the commencement of the activities identified in the notice or as described in the Contract Documents.

- 1.24 Plans - The official graphic representations of this Project that are a part of the Contract Documents.
- 1.25 Premises (otherwise known as Site or Work Site) – means the land, buildings, facilities, etc. upon which the Work is to be performed.
- 1.26 Project – The construction project described in the Contract Documents, including the Work described therein.
- 1.27 Project Manager - The employee of the City, or other designated individual who is herein referred to as the Project Manager, will assume all duties and responsibilities and will have the rights and authorities assigned to the Project Manager in the Contract Documents in connection with completion of the Work in accordance with this Agreement. The Project Manager, or designee, shall be the authorized agent for the City unless otherwise specified.
- 1.28 Punch List - The City's list of Work yet to be done or be corrected by the Contractor, before the Final Completion date can be determined by the City.
- 1.29 Record Documents - A complete set of all specifications, drawings, addenda, modifications, shop drawings, submittals and samples annotated to show all changes made during the construction process.
- 1.30 Record Drawings or "As-Builts" - A set of drawings which show significant changes in the work made during construction and which are usually based on drawings marked up in the field and other data furnished by the Contractor. These documents will be signed and sealed by a Professional Engineer, or a Professional Land Surveyor licensed in the State of Florida and employed by the Contractor at no cost to the City.
- 1.31 Substantially Completed Date – A date when written notice is provided by the City to the Contractor stating that the Work is substantially completed. If, at the time of inspection, it is determined the project is substantially completed, the City will also issue a letter of Substantial Completion along with a punch list of incomplete or deficient items to be completed prior to requesting a Final Completion inspection.
- 1.32 Work – The construction and services required by the Contract Documents, whether completed or partially completed, and includes all labor, materials, equipment, and services provided or to be provided by Contractor to fulfill Contractor's obligations. The Work may constitute the whole or a part of the Project.

## **ARTICLE 2 – SCOPE OF WORK**

- 2.1 The Contractor shall complete all Work as specified or indicated in the Contract Documents. The Project for which the Work under the Contract Documents may be the whole or only part is generally described as follows:

George T. Lohmeyer WWTP Deep Injection Well Cleaning  
Event ITB #191 PROJECT # P12798

- 2.2 All Work for the Project shall be constructed in accordance with the approved plans and Specifications. The Work generally involves:

### PROJECT DESCRIPTION

This project is located at the George T. Lohmeyer Wastewater Treatment Plant (GTL WWTP), 1000 SE 21 Street, Fort Lauderdale, Florida, 33316 in the City of Fort Lauderdale. The work to be accomplished under this solicitation includes, but is not limited to, furnishing all labor, materials and equipment to perform mechanical integrity testing (MIT) of five (5) existing Class I injection wells.

The Injection Wells have a 24-inch outside diameter (OD), 0.500-inch wall thickness injection casing set to total depths of 2,800 to 2,820 feet below land surface (BLS) and were constructed with a nominal 22-inch diameter open borehole extending from the bottom of the casing to approximately 3,305 to 4,010 feet BLS. Also, this project includes the replacement of some piping, painting and required appurtenances at each injection well.

- 2.3 Within ten (10) days of the execution of this Agreement, the Contractor shall submit a Construction Schedule, Schedule of Values and a listing of all personnel employed. The general sequence of the Work shall be submitted by the Contractor and approved by the City before any work commences. The City reserves the right to issue construction directives necessary to facilitate the Work or to minimize any conflict with operations.

### ARTICLE 3 – PROJECT MANAGER

- 3.1 The Project Manager is hereby designated by the City as Justin Murray, P.E., whose address is 1765 SE 18th Street, Administration Building Main Floor, Fort Lauderdale, FL 33316, telephone number: (954) 828-4122, and email address is [jmurray@fortlauderdale.gov](mailto:jmurray@fortlauderdale.gov). The Project Manager will assume all duties and responsibilities and will have the rights and authorities assigned to the Project Manager in the Contract Documents in connection with completion of the Work in accordance with this Agreement.

### ARTICLE 4 – CONTRACT DOCUMENTS

The Contract Documents, which comprise the entire Agreement between the City and Contractor, are incorporated herein and attached to this Agreement, and consist of the following:

- 4.1 This Agreement.
- 4.2 Exhibits to this Agreement: (Plans sheets [ ] to [ ] inclusive).
- 4.3 Public Construction Bond, Performance Bond, Payment Bond and Certificates of Insurance.
- 4.4 Notice of Award and Notice to Proceed.
- 4.5 General Conditions and Special Conditions.

- 4.6 Technical Specifications.
- 4.7 Plans/Drawings.
- 4.8 Addenda number \_\_\_\_\_ through \_\_\_\_\_, inclusive.
- 4.9 Bid Form and supplement Affidavits and Agreements.
- 4.10 All applicable provisions of State and Federal Law.
- 4.11 Invitation to Bid No. 191, Instructions to Bidders, and Bid Bond.
- 4.12 Contractor's response to the City's Invitation to Bid No. 191, dated \_\_\_\_\_.
- 4.13 Schedule of Completion.
- 4.14 All amendments, modifications and supplements, change orders and work directive changes, issued on or after the Effective Date of the Agreement.
- 4.15 Any additional documents that are required to be submitted under the Agreement.
- 4.16 Permits on file with the City and or those permits to be obtained shall be considered directive in nature and will be considered a part of this Agreement.

In the event of any conflict between the documents or any ambiguity or missing specification or instruction, the following priority is established:

- a. Approved change orders, addenda or amendments.
- b. Specifications and Drawings.
- c. Special Conditions.
- d. General Conditions.
- e. This Agreement dated \_\_\_\_\_, and any attachments.
- f. Invitation to Bid No. 191, and the specifications prepared by the City.
- g. Contractor's response to the City's Invitation to Bid No. 191, dated \_\_\_\_\_.
- h. Schedule of Values.
- i. Schedule of Completion.

If during the performance of the Work, Contractor finds a conflict, error or discrepancy in the Contract Documents, Contractor shall so report to the Project Manager, in writing, within five



(5) calendar days, and before proceeding with the Work affected shall obtain a written interpretation or clarification from the City.

Any Work that may reasonably be inferred from the specifications or plans as being required to produce the intended result shall be supplied whether or not it is specifically called for. When words which have a well-known technical or trade meaning are used to describe Work, materials, or equipment, such works shall be interpreted in accordance with such meaning. Reference to standard specifications, manuals or codes of any technical society, organization or associations, or to the code of any governmental authority whether such reference be specific or implied, shall mean the latest standard specification, manual or code in effect as of the Effective Date of this Agreement, except as may be otherwise specifically stated. However, no provision of any referenced standard specification, manual or code (whether or not specifically incorporated by reference in the Contract Documents) shall change the duties and responsibilities of the City, the Contractor, or any of their agents or employees from those set forth in the Contract Documents.

#### **ARTICLE 5 – CONTRACT TIME**

- 5.1 The Contractor recognizes that **TIME IS OF THE ESSENCE**. The Work shall commence within seven (7) calendar days of the date of the Notice to Proceed.
- 5.2 The Work shall be Substantially Completed within one hundred (100) calendar days after the date when the Contract Time commences to run as provided in the Notice to Proceed.
- 5.3 The Work shall be finally completed on the Final Completion Date and ready for final payment in accordance with this Agreement within one hundred twenty (120) calendar days after the Substantial Completion date.

#### **ARTICLE 6 – CONTRACT PRICE**

- 6.1 City shall pay Contractor for performance of the Work in accordance with Article 7, subject to additions and deletions by Change Order, as provided for in this Agreement.
- 6.2 The Parties expressly agree that the Contract Price, which shall not exceed the amount of \$ [REDACTED], constitutes the total maximum compensation payable to Contractor for performing the Work, plus any Work done pursuant to a Change Order. The Contract Price is in accordance with the line items unit prices listed in the Bid. Line items are based on a unit price cost multiplied by a defined quantity. Any additional duties, responsibilities and obligations assigned to or undertaken by Contractor shall be at Contractor's expense without change to the Contract Price.
- 6.3 The Contract Price constitutes the compensation payable to Contractor for performing the Work plus any Work done pursuant to a Change Order. All duties, responsibilities and obligations assigned to or undertaken by Contractor shall be at Contractor's expense without change in the Contract Price.

#### **ARTICLE 7 – PAYMENT**

- 7.1 Contractor shall submit Applications for Payment in accordance with the Contract Documents. Applications for Payment will be processed by City as provided for in the General Conditions.
- 7.2 Progress Payments. City shall make progress payments on account of the Contract Price on the basis of Contractor's monthly Applications for Payment, which shall be submitted by the Contractor between the first (1<sup>st</sup>) and the tenth (10<sup>th</sup>) day after the end of each calendar month for which payment is requested. All progress payments will be made on the basis of the progress of the Work completed.
- 7.3 Prior to Final Completion, progress payments will be made in an amount equal to ninety-five percent (95%) of the value of Work completed less in each case the aggregate of payments previously made.
- 7.4 Final Payment. Upon final completion of the Work in accordance with the General Conditions, as may be supplemented, the City shall pay Contractor an amount sufficient to increase total payments to one hundred percent (100%) of the Contract Price. However, not less than five percent (5%) of the Contract Price shall be retained until Record Drawings (as-builts), specifications, addenda, modifications, and shop drawings, including all manufacturers' instructional and parts manuals are delivered to and accepted by the City.
- 7.5 City may withhold, in whole or in part, payment to such extent as may be necessary to protect itself from loss on account of:
  - 7.5.1 Defective work not remedied.
  - 7.5.2 Claims filed or reasonable evidence indicating probable filing of claims by other parties against Contractor or City because of Contractor's performance.
  - 7.5.3 Failure of Contractor to make payments properly to subcontractors or for material or labor.
  - 7.5.4 Damage to another contractor not remedied.
  - 7.5.5 Liquidated damages and costs incurred by Consultant for extended construction administration, if applicable.
  - 7.5.6 Failure of Contractor to provide any and all documents required by the Contract Documents.

When the above grounds are removed or resolved satisfactory to the Project Manager, payment shall be made in whole or in part.

- 7.6 The City shall make payment to the Contractor in accordance with the Florida Prompt Payment Act, Section 218.70, Florida Statutes (2022), as amended or revised, provided, however, complete and error free pay application is submitted.
- 7.7 The City shall make payment to the Contractor through utilization of the City's Purchasing Card (P-Card) Program. The City has implemented a P-Card Program utilizing the MASTERCARD and VISA networks. Purchases from this contract will be made utilizing the City's P-Card. Contractor will receive payment from the purchasing

card in the same manner as other credit card purchases. Accordingly, Contractor must presently have the ability to accept these credit cards or take whatever steps necessary to implement the ability before the start of the contract term, or contract award by the City. All costs associated with the Contractor's participation in this purchasing program shall be borne by the Contractor. The City reserves the right to revise this program as necessary.

#### 7.8 Payment Card Industry (PCI) Compliance

Contractor agrees to comply with all applicable state, federal and international laws, as well as industry best practices, governing the collection, access, use, disclosure, safeguarding and destruction of Protected Information.

Contractor and/or any subcontractor that handles credit card data must be, and remain, PCI compliant under the current standards and will provide documentation confirming compliance upon request by the City of Fort Lauderdale. Failure to produce documentation could result in termination of the contract.

### **ARTICLE 8 – CONTRACTOR'S REPRESENTATIONS**

In order to induce the City to enter into this Agreement, Contractor makes the following representations upon which the City has relied:

- 8.1 Contractor is qualified in the field of public construction and in particular to perform the Work and services set forth in this Agreement.
- 8.2 Contractor has visited the Work Site, has conducted extensive tests, examinations and investigations and represents and warrants a thorough familiarization with the nature and extent of the Contract Documents, the Work, locality, soil conditions, water table condition, moisture conditions and all year-round local weather and climate conditions (past and present), and examination and investigations conducted by Contractor and the Contractor's experts, has determined that no conditions exist that would in any manner affect the Bid Price and that the project can be completed for the Bid Price submitted within the Contract Time as defined in this Agreement.

Furthermore, Contractor warrants and confirms that it is totally familiar with, understands and obligates Contractor to comply with all federal, state and local laws, ordinances, rules, regulations and all market conditions that affect or may affect the cost and price of materials and labor needed to fulfill all provisions of this Agreement or that in any manner may affect cost, progress or performance of the Work.

- 8.3 The Contractor has satisfied itself as to the nature and location of the Work under the Contract Documents, the general and local conditions of the Project, particularly those bearing upon availability of transportation, disposal, handling and storage of materials, availability of labor, water, electric power, and roads, the conformation and conditions at the ground based on City provided reports, the type of equipment and facilities needed

preliminary to and during the prosecution of the Work and all other matters which can in any way affect the Work or the cost thereof under the Contract Documents.

- 8.4 The Contractor has also studied on its own, investigations and tests of subsurface and latent physical conditions at the site or otherwise affecting cost, progress or performance of the Works, and finds and has further determined that no conditions exist that would in any manner affect the Bid Price and that the Project can be completed for the Bid Price submitted.
- 8.5 Contractor has made or caused to be made, examinations, investigations, tests and studies of such reports and related data in addition to those referred to in Paragraphs 8.2, 8.3 and 8.4 above as it deems necessary for the performance of the Work at the Contract Prices, within the Contract Time and in accordance with the other terms and conditions of the Contract Documents; and no additional examinations, investigations, tests, reports or similar data are, or will be, required by Contractor for such purposes.
- 8.6 Contractor has correlated the results of all such observations, examinations, investigations, tests, reports and data with the terms and conditions of the Contract Documents.
- 8.7 Contractor has given City written notice of all conflicts, errors or discrepancies that it has discovered in the Contract Documents and the written resolution by City is acceptable to the Contractor.
- 8.8 Labor
- 8.8.1 The Contractor shall provide competent, suitable qualified personnel to survey and lay out the Work and perform construction as required by the Contract Documents. The Contractor shall at all times maintain good discipline and order at the site.
- 8.8.2 The Contractor shall, at all times, have a competent superintendent, capable of reading and thoroughly understanding the drawings and specifications, as the Contractor's agent on the Work, who shall, as the Contractor's agent, supervise, direct and otherwise conduct the Work.
- 8.8.3 The Contractor shall designate the superintendent on the job to the City, in writing, immediately after receipt of the Notice to Proceed. The Contractor understands and agrees that the superintendent's physical presence on the job site is indispensable to the successful completion of the Work. If the superintendent is frequently absent from the job site, the Project Manager may deliver written notice to the Contractor to stop work or terminate the Agreement in accordance with Article 17.
- 8.8.4 Where required and necessary, the Contractor shall, at all times, have a certified "competent person" assigned to the job site. The Contractor shall assign personnel to the job site that have successfully completed training programs related to trench safety, confined space work, and maintenance of traffic (MOT). Personnel certified by the International Municipal Signal Associations with Florida

Department of Transportation qualifications are required relative to MOT. Any other certifications that may be required by applicable permitting agencies for the Work shall also be complied with by the Contractor. Failure to pursue the Work with the properly certified supervisory staff may result in notice to stop work or terminate the Agreement in accordance with Article 17.

8.9 Materials:

8.9.1 The Contractor shall furnish all materials, equipment, labor, transportation, construction equipment and machinery, tools, appliances, fuel, power, light, heat, telephone, water and sanitary facilities and all other facilities and incidentals necessary for the execution, testing, initial operation and completion of Work.

8.9.2 All materials and equipment shall be of good quality and new, except as otherwise provided in the Contract Documents. Suppliers shall be selected and paid by the Contractor; the City reserves the right to approve all suppliers and materials.

8.10 Work Hours: Except in connection with the safety or protection of persons, or the Work, or property at the site or adjacent thereto, and except as otherwise indicated in the Supplementary Conditions, all work at the site shall be performed during regular working hours between 8 a.m. and 5:00 p.m., Monday through Friday.

Unless approved by the City in advance, the Contractor will not perform work on Saturday, Sunday or any legal holiday (designated by the City of Fort Lauderdale) without the Project Manager's written consent at least seventy-two (72) hours in advance of starting such work. For any overtime inspection required by City personnel, the Contractor shall pay for the additional charges to the City with respect to such overtime work. Such additional charges shall be a subsidiary obligation of the Contractor and no extra payment shall be made to the Contractor for overtime work. **It shall be noted that the City's Inspector work hours are from 8:00 a.m. to 4:30 p.m., Monday through Friday, and any work requiring inspection oversight being performed outside of this timeframe shall be paid for by the Contractor as Inspector overtime at a rate of \$100.00 per hour.** The cost to the Contractor to reimburse the City for overtime inspection is established at direct-labor and overtime costs for each person or inspector required. Incidental overtime costs for engineering, testing and other related services will also be charged to the Contractor at the actual rate accrued.

8.11 Patent Fee and Royalties: The Contractor shall pay all license fees and royalties and assume all costs incident to the use in the performance of the Work or the incorporation in the Work, or any invention, design, process, product or device which is the subject of patent rights or copyrights held by others. The Contractor hereby expressly binds itself to indemnify and hold harmless the City from all such claims and fees and from any and all suits and action of every name and description that may be brought against City on account of any such claims, fees, royalties, or costs for any such invention or patent, and from any and all suits or actions that may be brought against said City for the infringement of any and all patents or patent rights claimed by any person, firm corporation or other entity.

- 8.12 Permits: The Contractor shall obtain and pay for all permits and licenses. There shall be no allowance for Contractor markup, overhead or profit for permits and licenses.

The Contractor shall pay all government charges which are applicable at the time of opening of bids. It shall be the responsibility of the Contractor to secure and pay for all necessary licenses and permits of a temporary nature necessary for the prosecution of Work.

- 8.13 Law and Regulations: The Contractor shall give all notices and comply with all laws, ordinances, rules and regulations applicable to the Work. If the Contractor observes that the specifications or plans are in conflict, the Contractor shall give the Project Manager prompt written notice thereof within five (5) calendar days, and any necessary changes shall be adjusted by any appropriate modifications. If the Contractor performs any work knowing or having reason to know that it is contrary to such laws, ordinances, rules, standards, specifications and regulations, and without such notice to the Project Manager, the Contractor shall bear all costs arising therefrom.

- 8.14 Taxes: The Contractor shall pay all sales, consumer, use and other similar taxes required to be paid by him in accordance with the laws of the City of Fort Lauderdale, County of Broward, and the State of Florida.

- 8.15 Contractor Use of Premises: The Contractor shall confine construction equipment, the storage of materials and equipment and the operations of workmen to areas permitted by law, ordinances, permits and/or the requirements of the Contract Documents, and shall not unreasonably encumber the premises with construction equipment or other materials or equipment.

The Contractor shall not enter upon private property for any purpose without first securing the permission of the property owner in writing and furnishing the Project Manager with a copy of said permission. This requirement will be strictly enforced, particularly with regard to such vacant properties as may be utilized for storage or staging by the Contractor.

The Contractor shall conduct its work in such a manner as to avoid damage to adjacent private or public property. Any damage to existing structures of work of any kind, including permanent reference markers or property corner markers, or the interruption of a utility service, shall be repaired or restored promptly at no expense to the City or property owner.

The Contractor will preserve and protect all existing vegetation such as trees, shrubs and grass on or adjacent to the site which do not reasonably interfere with the construction, as determined by the Project Manager. The Contractor will be responsible for repairing or replacing any trees, shrubs, lawns and landscaping that may be damaged due to careless operation of equipment, stockpiling of materials, tracking of grass by equipment or other construction activity. The Contractor will be liable for or will be required to replace or restore at no expense to the City all properties and areas not protected or preserved as required herein that may be destroyed or damaged.

During the progress of the Work, the Contractor shall keep the premises free from accumulation of waste materials, rubbish and debris resulting from the Work. At the completion of the Work, the Contractor shall remove all waste materials, rubbish and debris from and about the premises as well as all tools, appliances, construction equipment and machinery, and surplus materials and shall leave the site clean and ready for occupancy by the City. The Contractor shall restore to their original condition those portions of the site not designated for alteration by the Contract Documents at no cost to the City.

8.16 Project Coordination: The Contractor shall provide for the complete coordination of the construction effort. This shall include, but not necessarily be limited to, coordination of the following:

- 8.16.1 Flow of material and equipment from suppliers.
- 8.16.2 The interrelated work with affected utility companies.
- 8.16.3 The interrelated work with the City where tie-ins to existing facilities are required.
- 8.16.4 The effort of independent testing agencies.
- 8.16.5 Notice to affected property owners as may be directed by the Project Manager.
- 8.16.6 Coordination with and scheduling of all required inspections from all permitting agencies.

8.17 Project Record Documents and Final As-Builts (Record Drawings): Contractor shall be responsible for maintaining up-to-date redline as-built drawings, on site, at all times during construction. All as-built information shall be surveyed and verified by a professional land surveyor registered in the State of Florida. Contractor shall provide the City with a minimum of three (3) sets of signed and sealed record drawings (Final As-Builts) and a CD of the electronic drawings files created in AutoCad 2014 or later. All costs associated with survey work required for construction layout and as-built preparation shall be the responsibility of the Contractor.

8.18 Safety and Protection:

8.18.1 The Contractor shall be responsible for initiating, maintaining and supervising all safety precautions and programs in connection with the Work. The Contractor shall take all necessary precautions for the safety of, and shall provide the necessary protection to prevent damage, injury or loss to:

- 8.18.1.1 All employees working on the project and other persons who may be affected thereby.
- 8.18.1.2 All the Work and all materials or equipment to be incorporated therein, whether in storage on or off the site.
- 8.18.1.3 Other property at the site or adjacent thereto, including trees, shrubs, lawns, walks, pavements, roadways, structures and utilities not designated for removal, relocation or replacement in the course of construction.

8.18.2 The Contractor shall comply with all applicable laws, ordinances, rules, regulations and orders of any public body having jurisdiction for the safety of persons or property or to protect them from damage, injury or loss; and shall erect and maintain all necessary safeguards for such safety and protection. The Contractor shall notify owners of adjacent property and utilities when execution of the Work may affect them at least seventy-two (72) hours in advance (unless otherwise required). All damage, injury or loss to any property caused, directly or indirectly, in whole or in part by the Contractor, any subcontractor or anyone directly or indirectly employed by any of them or anyone for whose acts any of them may be liable, shall be remedied by the Contractor. The Contractor's duties

and responsibilities for safety and protection of the Work shall continue until such time as all the Work is completed and accepted by the City.

- 8.19 Emergencies: In emergencies affecting the safety or protection of persons or the Work or property at the site or adjacent thereto, the Contractor, without special instruction or authorization from the City, is obligated to act to prevent threatened damage, injury or loss. The Contractor shall give the Project Manager prompt written notice of any significant changes in the Work or deviations from the Contract Documents caused thereby.
- 8.20 Risk of Loss: The risk of loss, injury or destruction shall be on the Contractor until acceptance of the Work by the City. Title to the Work shall pass to the City upon acceptance of the Work by the City.
- 8.21 Environmental: The Contractor has fully inspected the Premises and agrees, except as to the presence of any asbestos, to accept the Premises in an "as is" physical condition, without representation or warranty by the City of any kind, including, without limitation, any and all existing environmental claims or obligations that may arise from the presence of any "contamination" on, in or about the Premises. Further, Contractor and all entities claiming by, through or under the Contractor, releases and discharges the City from any claim, demand, or cause of action arising out of or relating to the Contractor's use, handling, storage, release, discharge, treatment, removal, transport, decontamination, cleanup, disposal and/or presence of any hazardous substances including asbestos on, under, from or about the Premises. The Contractor shall have no liability for any pre-existing claims or "contamination" on the Premises.

The Contractor shall not use, handle, store, discharge, treat, remove, transport, or dispose of Hazardous Substances including asbestos at, in, upon, under, to or from the Premises until receipt of instructions from the City. At such time, a City approved Change Order, which shall not include any profit, shall authorize the Contractor to perform such services.

The Contractor shall immediately deliver to the Project Manager complete copies of all notices, demands, or other communications received by the Contractor from any governmental or quasi-governmental authority or any insurance company or board of fire underwriters or like or similar entities regarding in any way alleged violations or potential violations of any Environmental Law or otherwise asserting the existence or potential existence of any condition or activity on the Premises which is or could be dangerous to life, limb, property, or the environment.



For other and additional consideration, the Contractor hereby agrees, at its sole cost and expense, to indemnify and protect, defend, and hold harmless the City and its respective employees, agents, officials, officers, representatives, contractors and subcontractors, successors, and assigns (hereafter the "City") from and against any and all claims, demands, losses, damages, costs, expenses, including but not limited to mitigation, restoration, and natural restoration expenses, liabilities, assessments, fines, penalties charges, administrative and judicial proceedings and orders, judgments, causes of action, in law or in equity, remedial action requirements and/or enforcement actions of any kind (including, without limitation, attorneys' fees and costs) directly or indirectly arising out of or attributable to, in whole or in part, the Contractor's use, handling, storage, release, threatened release, discharge, treatment, removal, transport, decontamination, cleanup, disposal and/or presence of a Hazardous Substance (excluding asbestos) on, under, from, to or about the Premises or any other activity carried on or undertaken on or off the Premises by the Contractor or its employees, agents or subcontractors, in connection with the use, handling, storage, release, threatened release, discharge, treatment, mitigation, natural resource restoration, removal, transport, decontamination, cleanup, disposal and/or presence of any Hazardous Substance including asbestos located, transported, or present on, undue, from, to, or about the Premises. This indemnity is intended to be operable under 42 U.S.C. Section 9607, as amended or revised, and any successor section.

The scope of the indemnity obligations includes, but is not limited to: (a) all consequential damages; (b) the cost of any required or necessary repair, cleanup, or detoxification of the applicable real estate and the preparation and implementation of any closure, remedial or other required plan, including without limitation; (i) the costs of removal or remedial action incurred by the United States government or the State of Florida or response costs incurred by any other person, or damages from injury to destruction of, or loss of, natural resources, including the cost of assessing such injury, destruction, or loss, incurred pursuant to the Comprehensive Environmental Response, Compensation and Liability Act, as amended; (ii) the clean-up costs, fines, damages, or penalties incurred pursuant to any applicable provisions of Florida law; and (iii) the cost and expenses of abatement, correction or cleanup, fines, damages, response costs, or penalties which arise from the provisions of any other statute, law, regulation, code ordinance, or legal requirement state or federal; and (c) liability for personal injury or property damage arising under any statutory or common law tort theory, including damages assessed for the maintenance of a public private nuisance, response costs, or for the carrying on of an abnormally dangerous activity.

8.22 No Extended Damages: For other and additional good and valuable consideration the receipt and sufficiency of which is hereby acknowledged, the Contractor covenants and agrees that in the event of any delay of construction or for any other reason or allegation or claim, and notwithstanding the reason of the delay, reason, claim or allegation or who caused them or the construction delay or whether they were caused by the City, that there will be no entitlement to Contractor to or for any direct or indirect financial damages or losses for extended corporate overhead impact, extended project overhead impacts, project support services, mobilization or demobilization or by whatever other label or legal concept or theory and types of names or labels or basis such claims may have, or any business damages or losses of whatever type or nature, and Contractor hereby

waives any right to make any such claim or claims. This provision will have application and effect when construction delays are anticipated and agreed upon by both the City and the Contractor.

- 8.23 No Liens: If any subcontractor, supplier, laborer, or materialmen of Contractor or any other person directly or indirectly acting for or through Contractor files or attempts to file a mechanic's or construction lien against the real property on which the Work is performed or any part or against any personal property or improvements or claim against any monies due or to become due from the City to Contractor or from Contractor to a subcontractor, for or on account of any work, labor, services, material, equipment, or other items furnished in connection with the Work or any Change Order, Contractor agrees to satisfy, remove, or discharge such lien or claim at its own expense by bond, payment, or otherwise within twenty (20) days of the filing or from receipt of written notice from the City.

Additionally, until such time as such lien or claim is satisfied, removed or discharged by Contractor, all monies due to Contractor, or that become due to Contractor before the lien or claim is satisfied, removed or otherwise discharged, shall be held by City as security for the satisfaction, removal and discharge of such lien and any expense that may be incurred while obtaining such. If Contractor shall fail to do so, City shall have the right, in addition to all other rights and remedies provided by this Agreement or by law, to satisfy, remove, or discharge such lien or claim by whatever means City chooses at the entire and sole cost and expense of Contractor which costs and expenses shall, without limitation, include attorney's fees, litigation costs, fees and expenses and all court costs and assessments.

- 8.24 Weather Emergencies: Upon issuance of a hurricane watch by the National Weather Service, the Contractor shall submit to the City a plan to secure the work area in the event a hurricane warning is issued. The plan shall detail how the Contractor will secure the Premises, equipment and materials in a manner as to prevent damage to the Work and prevent materials and equipment from becoming a hazard to persons and property on and around the Premises. The plan shall include a time schedule required to accomplish the hurricane preparations and a list of emergency contacts that will be available, and in the City before, during and immediately after the storm.

Upon issuance of a hurricane warning by the National Weather Service, if the Contractor has not already done so, the Contractor shall implement its hurricane preparedness plan. Cost of development and implementation of the hurricane preparedness plan shall be considered as incidental to construction. Cost of any clean up and rework required after the storm will be considered normal construction risk within Florida and shall not entitle the Contractor to any additional compensation. Contractor shall be entitled to request an extension in time for completion of the Work, in accordance with the provisions of Article 15 of this Agreement, equal to the time it is shut down for implementation of the preparedness plan, the duration of the storm and a reasonable period to restore the Premises.

- 8.25 Force Majeure: No Party shall hold the other responsible for damages or for delays in performance caused by force majeure, acts of God, or other acts or circumstances beyond the control of the other Party or that could not have been reasonably foreseen

and prevented. For this purpose, such acts or circumstances shall include, but not be limited to weather conditions affecting performance, floods, epidemics, pandemics, war, act of Governmental Authority, state of emergency, riots, strikes, lockouts, or other industrial disturbances, or protest demonstrations. Should such acts or circumstances occur, the Parties shall use their best efforts to overcome the difficulties arising therefrom and to resume the Work as soon as reasonably possible with the normal pursuit of the Work.

Inclement weather, continuous rain for less than three (3) days or the acts or omissions of subcontractors, third-party contractors, materialmen, suppliers, or their subcontractors, shall not be considered acts of force majeure.

No Party shall be liable for its failure to carry out its obligations under the Agreement during a period when such Party is rendered unable by force majeure to carry out its obligation, but the obligation of the Party or Parties relying on such force majeure shall be suspended only during the continuance of the inability and for no longer period than the unexpected or uncontrollable event.

The Contractor further agrees and stipulates, that its right to excuse its failure to perform by reason of force majeure shall be conditioned upon giving written notice of its assertion that a Force Majeure delay has commenced within ninety-six (96) hours after such an occurrence. The Contractor shall use its reasonable efforts to minimize such delays. The Contractor shall promptly provide an estimate of the anticipated additional time required to complete the Project.

- 8.26 Participation by Disadvantaged Business Enterprises in Department of Transportation Financial Assisted Contracts: The recipient shall not discriminate on the basis of race, color, national origin, or sex in the award and performance of any DOT-assisted contract or in the administration of its DBE program or the requirements of 49 CFR Part 26. The recipient shall take all necessary and reasonable steps under 49 CFR Part 26 to ensure nondiscrimination in the award and administration of DOT-assisted contracts. The recipient's DBE program, as required by 49 CFR Part 26 and as approved by DOT, is incorporated by reference in this Agreement. Implementation of this program is a legal obligation and failure to carry out its terms shall be treated as a violation of this Agreement. Upon notification to the recipient of its failure to carry out its approved program, the Department may impose sanctions as provided for under Part 26 and may, in appropriate cases, refer the matter for enforcement under 18 U.S.C. 1001 and/or the Program Fraud Civil Remedies Act of 1986 (31 U.S.C. 3801 *et seq.*).

Additionally, the Contractor assures that it, the sub-recipient or its subcontractors shall not discriminate on the basis of race, color, national origin, or sex in the performance of this Agreement. The Contractor shall carry out applicable requirements of 49 CFR Part 26 in the award and administration of DOT-assisted contracts. Failure by the Contractor to carry out these requirements is a material breach of this Agreement, which may result in the termination of this Agreement or such other remedy as the recipient deems appropriate. This additional language must be included in each subcontract the prime Contractor signs with a subcontractor.

## **ARTICLE 9 – CITY'S RESPONSIBILITIES**

- 9.1 The City shall furnish the data required of the City under the Contract Documents promptly and shall make payments to the Contractor promptly after they are due as provided in Article 7.
- 9.2 The City shall provide public rights-of-way and easement, where available, for the installation of conduits, transformers pads and related appurtenances only.
- 9.3 Technical Clarifications and Interpretations:
- 9.3.1 The City shall issue, with reasonable promptness, such written clarifications or interpretations of the Contract Documents as it may determine necessary, which shall be consistent with or reasonably inferable from the overall intent of the Contract Documents. Should the Contractor fail to request interpretation of questionable items in the Contract Documents, the City shall not entertain any excuse for failure to execute the Work in a satisfactory manner.
- 9.3.2 The City shall interpret and decide matters concerning performance under the requirements of the Contract Documents, and shall make decisions on all claims, disputes or other matters in question. Written notice of each claim, dispute or other matter will be delivered by claimant to the other Party but in no event later than five (5) days after the occurrence of event and written supporting data will be submitted to the other Party within five (5) days after such occurrence. All written decisions of the City on any claim or dispute will be final and binding.
- 9.4 The Contractor shall perform all Work to the reasonable satisfaction of the City in accordance with the Contract Documents. In cases of disagreement or ambiguity, the City shall decide all questions, difficulties, and disputes of whatever nature, which may arise under or by reason of this Agreement or the quality, amount and value of the Work, and the City's decisions on all claims, questions and determination are final.
- 9.5 Cancellation for Unappropriated Funds: The obligation of the City for payment to a Contractor is limited to the availability of funds appropriated in a current fiscal period, and continuation of the Agreement into a subsequent fiscal period is subject to appropriation of funds, unless otherwise authorized by law.

## **ARTICLE 10 – BONDS AND INSURANCE**

- 10.1 Public Construction and Other Bonds: The Contractor shall furnish Public Construction or Performance and Payment Bonds ("Bond"), each in an amount at least equal to the Contract Price as security for the faithful performance and payment of all the Contractor's obligations under the Contract Documents. These Bonds shall remain in effect until at least one (1) year after the date of final payment, except as otherwise provided by law. All Bonds shall be furnished and provided by the surety and shall be in substantially the same form as prescribed by the Contract Documents and be executed by such sureties as (i) are licensed to conduct business in the State of Florida, and (ii) are named in the current list of Companies Holding Certificates of Authority as Acceptable Sureties on Federal Bonds and as Acceptable Reinsuring Companies as published in Circular 570 (amended) by the Audit Staff Bureau of Accounts, U.S.

Treasury Department and (iii) otherwise meet the requirements set forth herein that apply to sureties. All Bonds signed by an agent must be accompanied by a certified copy of the authority to act.

10.1.1 Performance Bond: The Contractor shall execute and record in the public records of Broward County, Florida, a payment and performance bond in an amount at least equal to the Contract Price with a surety insurer authorized to do business in the State of Florida as surety, ("Bond"), in accordance with Section 255.05, Florida Statutes (2022), as may be amended or revised, as security for the faithful performance and payment of all of the Contractor's obligations under the Contract Documents.

A Corporate Surety Bond legally issued, meeting the approval of, and running to the City in an amount not less than the Contract Price of such improvements, conditioned that the Contractor shall maintain and make all repairs to the improvements constructed by the Contractor at their own expense and free of charge to the City, for the period of one (1) year after the date of acceptance of the Work within such period by reason of any imperfection of the material used or by reason of any defective workmanship, or any improper, imperfect or defective preparation of the base upon which any such improvement shall be laid.

10.2 Disqualification of Surety: If the Surety on any Bond furnished by the Contractor is declared bankrupt or becomes insolvent or its right to do business is terminated in the State of Florida or it ceases to meet the requirements of clauses (i) and (ii) of Paragraph 10.1, the Contractor shall within five (5) days thereafter substitute another Bond and Surety, both of which shall be acceptable to the City.

### 10.3 Insurance

As a condition precedent to the effectiveness of this Agreement, during the term of this Agreement and during any renewal or extension term of this Agreement, Contractor, at its sole expense, shall provide insurance of such types and with such terms and limits as noted below. Providing proof of and maintaining adequate insurance coverage are material obligations of Contractor. Contractor shall provide the City a certificate of insurance evidencing such coverage. Contractor's insurance coverage shall be primary insurance for all applicable policies, in respect to the City's interests. The limits of coverage under each policy maintained by Contractor shall not be interpreted as limiting Contractor's liability and obligations under this Agreement. All insurance policies shall be through insurers authorized or eligible to write policies in the State of Florida and possess an A.M. Best rating of A-, VII or better, subject to approval by the City's Risk Manager.

The coverages, limits, and/or endorsements required herein protect the interests of the City, and these coverages, limits, and/or endorsements shall in no way be relied upon by Contractor for assessing the extent or determining appropriate types and limits of coverage to protect Contractor against any loss exposures, whether as a result of this Agreement or otherwise. The requirements contained herein, as well as the City's review or acknowledgement, are not intended to and shall not in any manner limit or qualify the liabilities and obligations assumed by Contractor under this Agreement.

The following insurance policies and coverages are required:

### Commercial General Liability

Coverage must be afforded under a Commercial General Liability policy with limits not less than:

- \$1,000,000 each occurrence and \$2,000,000 aggregate for Bodily Injury, Property Damage, and Personal and Advertising Injury
- \$1,000,000 each occurrence and \$2,000,000 aggregate for Products and Completed Operations

Policy must include coverage for contractual liability and independent contractors.

The City, a Florida municipality, its officials, employees, and volunteers are to be covered as an additional insured with a CG 20 26 04 13 Additional Insured – Designated Person or Organization Endorsement or similar endorsement providing equal or broader Additional Insured Coverage with respect to liability arising out of activities performed by or on behalf of Contractor. The coverage shall contain no special limitation on the scope of protection afforded to the City, its officials, employees, and volunteers.

### Crane and Rigging Liability

Coverage must be afforded for any crane operations under the Commercial General or Business Automobile Liability policy as necessary, in line with the limits of the associated policy.

### Business Automobile Liability

Coverage must be afforded for all Owned, Hired, Scheduled, and Non-Owned vehicles for Bodily Injury and Property Damage in an amount not less than \$1,000,000 combined single limit each accident.

If Contractor does not own vehicles, Contractor shall maintain coverage for Hired and Non-Owned Auto Liability, which may be satisfied by way of endorsement to the Commercial General Liability policy or separate Business Auto Liability policy.

### Workers' Compensation and Employer's Liability

Coverage must be afforded per Chapter 440, Florida Statutes. Any person or entity performing work for or on behalf of the City must provide Workers' Compensation insurance. Exceptions and exemptions will be allowed by the City's Risk Manager, if they are in accordance with Florida Statute.

Contractor waives, and Contractor shall ensure that Contractor's insurance carrier waives, all subrogation rights against the City, its officials, employees, and volunteers for all losses or damages. The City requires the policy to be endorsed with WC 00 03 13 Waiver of our Right to Recover from Others or equivalent.

Contractor must be in compliance with all applicable State and Federal workers' compensation laws, including the U.S. Longshore and Harbor Workers' Compensation Act and the Jones Act, if applicable.

### Insurance Certificate Requirements

- a. Contractor shall provide the City with valid Certificates of Insurance (binders are unacceptable) no later than ten (10) days prior to the start of work contemplated in this Agreement.
- b. Contractor shall provide to the City a Certificate of Insurance having a thirty (30) day notice of cancellation; ten (10) days' notice if cancellation is for nonpayment of premium.

- c. In the event that the insurer is unable to accommodate the cancellation notice requirement, it shall be the responsibility of Contractor to provide the proper notice. Such notification will be in writing by registered mail, return receipt requested, and addressed to the certificate holder.
- d. In the event the Agreement term or any surviving obligation of Contractor following expiration or early termination of the Agreement goes beyond the expiration date of the insurance policy, Contractor shall provide the City with an updated Certificate of Insurance no later than ten (10) days prior to the expiration of the insurance currently in effect. The City reserves the right to suspend the Agreement until this requirement is met.
- e. The Certificate of Insurance shall indicate whether coverage is provided under a claims-made or occurrence form. If any coverage is provided on a claims-made form, the Certificate of Insurance must show a retroactive date, which shall be the effective date of the initial contract or prior.
- f. The City shall be covered as an Additional Insured on all liability policies, with the exception of Workers' Compensation.
- g. The City shall be granted a Waiver of Subrogation on Contractor's Workers' Compensation insurance policy.
- h. The title of the Agreement, Bid/Contract number, event dates, or other identifying reference must be listed on the Certificate of Insurance.

The Certificate Holder should read as follows:

City of Fort Lauderdale  
100 N. Andrews Avenue  
Fort Lauderdale, FL 33301

Contractor has the sole responsibility for all insurance premiums and shall be fully and solely responsible for any costs or expenses as a result of a coverage deductible, co-insurance penalty, or self-insured retention; including any loss not covered because of the application of such deductible, co-insurance penalty, self-insured retention, or coverage exclusion or limitation. Any costs for adding the City as an Additional Insured shall be at Contractor's expense.

If Contractor's primary insurance policy/policies do not meet the minimum requirements as set forth in this Agreement, Contractor may provide evidence of an Umbrella/Excess insurance policy to comply with this requirement.

Contractor's insurance coverage shall be primary insurance in respect to the City's interests, a Florida municipality, its officials, employees, and volunteers. Any insurance or self-insurance maintained by the City shall be non-contributory.

Any exclusion or provision in any insurance policy maintained by Contractor that excludes coverage required in this Agreement shall be deemed unacceptable and shall be considered breach of contract.

All required insurance policies must be maintained until the Agreement work has been accepted by the City, or until this Agreement is terminated, whichever is later. Any lapse in coverage may be considered breach of contract. In addition, Contractor must provide to the City confirmation of coverage renewal via an updated certificate of insurance should any policies expire prior to the expiration of this Agreement. The City reserves the right to review, at any time, coverage forms and limits of Contractor's insurance policies.

Contractor shall provide notice of any and all claims, accidents, and any other occurrences associated with this Agreement to Contractor's insurance company or companies and the City's Risk Management office as soon as practical.

It is Contractor's responsibility to ensure that any and all of Contractor's independent contractors and subcontractors comply with these insurance requirements. All coverages for independent contractors and subcontractors shall be subject to all of the applicable requirements stated herein. Any and all deficiencies are the responsibility of Contractor. The City reserves the right to adjust insurance limits from time to time at its discretion with notice to Contractor.

**NOTE: CITY PROJECT NUMBER, PROJECT NAME AND BID NUMBER MUST APPEAR ON EACH CERTIFICATE, AND THE CITY OF FORT LAUDERDALE MUST BE NAMED ON THE CERTIFICATE AS AN "ADDITIONAL INSURED" ON REQUIRED LIABILITY POLICIES.**

**A Sample Insurance Certificate shall be included with the bid to demonstrate the firm's ability to comply with insurance requirements. Provide a previous certificate or other evidence listing the insurance companies' names for all required coverage, and the dollar amounts of the coverage.**

#### **ARTICLE 11- WARRANTY AND GUARANTEE, TESTS AND INSPECTIONS, CORRECTION, REMOVAL OR ACCEPTANCE OF DEFECTIVE WORK**

- 11.1 Warranty: The Contractor warrants and guarantees to the City that all Work will be in accordance with the Contract Documents and will not be defective. Prompt notice of all defects shall be given to the Contractor. All defective work, whether or not in place, may be rejected, corrected or accepted as provided in this Article.
- 11.1.1 Warranty of Title: The Contractor warrants to the City that it possesses good, clear and marketable title to all equipment and materials provided and that there are no pending liens, claims or encumbrances against the equipment and materials.
- 11.1.2 Warranty of Specifications: The Contractor warrants that all equipment, materials and workmanship furnished, whether furnished by the Contractor, its subcontractors or suppliers, will comply with the specifications, drawings and other descriptions supplied or adopted and that all services will be performed in a workmanlike manner.
- 11.1.3 Warranty of Merchantability: The Contractor warrants that any and all equipment to be supplied pursuant to this Agreement is merchantable, free from defects, whether patent or latent in material or workmanship, and fit for the ordinary purposes for which it is intended.
- 11.2 Tests and Inspections: Contractor shall retain the services of an independent, certified, testing lab to perform all testing as required by the specifications, contract drawings, and any applicable permitting agency. Contractor shall provide evidence of certification to the City before the work and testing is done. Testing results shall be submitted to the Project Manager for review and approval at the time the results are provided to the



Contractor. The Contractor shall give the Project Manager and City Inspector a minimum of twenty-four (24) hours' advanced notice of readiness of the Work for all required inspections, tests, or approvals and shall notify all applicable permitting agencies in a timely manner based on requirements set forth in the permit documents.

11.2.1 Neither observations by the Project Manager nor inspections, tests or approvals by others shall relieve the Contractor from its obligations to perform the Work in accordance with the Contract Documents.

11.3 Uncovering Work: If any work that is to be inspected, tested or approved is covered without approval or consent of the Project Manager, it must, if requested by the Project Manager, be uncovered for observation and/or testing. Such uncovering and replacement shall be at the Contractor's sole expense unless the Contractor has given the Project Manager timely notice of the Contractor's intention to cover such Work and the Project Manager has not acted with reasonable promptness in response to such notice.

11.3.1 If the Project Manager considers it necessary or advisable that Work covered in accordance with Paragraphs 11.2.1 be observed by the City or inspected or tested by others, the Contractor at the City's request, shall uncover, expose or otherwise make available for observation, inspection or testing as the Project Manager may require, that portion of the Work in question, furnishing all necessary labor, material and equipment. If it is found that such Work is defective, the Contractor shall bear all the expenses of such uncovering, exposure, observation, inspection and testing and of satisfactory reconstruction, including compensation for additional professional services, and an appropriate deductive Change Order shall be issued. If, however, such work is not found to be defective, the Contractor shall be allowed an increase in the Contract Price or an extension of the Contract Time, or both, directly attributable to such uncovering, exposure, observation, inspection testing and reconstruction if it makes a claim therefore as provided in Articles 14 and 15.

11.4 City May Stop the Work: If the Work is defective, or the Contractor fails to supply sufficient skilled supervisory personnel or workmen or suitable materials or equipment or the work area is deemed unsafe, the City may order the Contractor to stop the Work, or any portion thereof, until the cause for such order has been eliminated; however, this right of the City to stop the Work shall not give rise to any duty on the part of the City to exercise this right for the benefit of the Contractor or any other Party. The City will not award any increase in Contract Price or Contract Time if the Work is stopped due to the circumstances described herein.

11.5 Correction or Removal of Defective Work Before Final Payment: If required by the Project Manager, the Contractor shall promptly, without cost to the City and as specified by the Project Manager, either correct any defective Work, whether or not fabricated, installed or completed, or if the Work has been rejected by the City remove it from the site and replace it with non-defective Work.

11.6 One Year Correction Period After Final Payment: If within one (1) year after the date of final acceptance, or such longer period of time as may be prescribed by law or by the terms of any applicable special guarantee required by the Contract Documents, any work is found

to be defective, the Contractor shall promptly, without cost to the City and in accordance with the City's written instructions, either correct such defective Work, or, if it has been rejected by the City, remove it from the site and replace it with non-defective Work.

If the Contractor does not promptly comply with the terms of such instructions or in an emergency where delay would cause serious risk of loss or damage, the City may have the defective Work corrected or the rejected Work removed and replaced, and all direct and indirect costs for such removal and replacement, including compensation for additional professional services, shall be paid by the Contractor.

- 11.7 Acceptance of Defective Work, Deductions: If, instead of requiring correction or removal and replacement of defective Work, the City, at the City's sole option, prefers to accept it, the City may do so. In such a case, if acceptance occurs prior to the Project Manager's recommendation of final payments, a Change Order shall be issued incorporating the necessary revisions in the Contract's Documents, including appropriate reduction in the Contract Price; or if the acceptance occurs after such recommendation, an appropriate amount shall be paid by the Contractor to the City.
- 11.8 City May Correct Defective Work: If the Contractor fails within a reasonable time after written notice of the Project Manager to proceed to correct defective Work or to remove and replace rejected Work as required by the Project Manager in accordance with Paragraph 11.5, or if the Contractor fails to perform the Work in accordance with the Contract Documents, the City may, after seven (7) days' written notice to the Contractor, correct and remedy any such deficiency. In exercising its rights under this paragraph, the City shall proceed expeditiously. To the extent necessary to complete corrective and remedial action, the City may exclude the Contractor from all or part of the site, take possession of all or part of the Work, suspend the Contractor's services related thereto and take possession of the Contractor's tools, construction equipment and materials stored at the site or elsewhere. The Contractor shall allow the City's representative agents and employees such access to the site as may be necessary to enable the City to exercise its rights under this paragraph. All direct and indirect costs of the City in exercising such rights shall be charged against the Contractor in an amount verified by the Project Manager, and a Change Order shall be issued incorporating the necessary revisions in the Contract Documents and a reduction in the Contract Price. Such direct and indirect costs shall include, in particular but without limitation, compensation for additional professional services required and costs of repair and replacement of work of others destroyed or damaged by correction, removal or replacement of the Contractor's defective Work. The Contractor shall not be allowed an extension of the Contract Time because of any delay in performance of the Work attributable to the exercise by the City of the City's right hereunder.

## **ARTICLE 12 – INDEMNIFICATION**

- 12.1 Disclaimer of Liability: The City shall not at any time, be liable for injury or damage occurring to any person or property from any cause, whatsoever, arising out of Contractor's construction and fulfillment of this Agreement.

12.2 Indemnification: For other, additional good valuable consideration, the receipt and sufficiency of which is hereby acknowledged:

12.2.1 Contractor shall, at its sole cost and expense, indemnify and hold harmless the City, its representatives, employees and elected and appointed officials from or on account of all claims, damages, losses, liabilities and expenses, direct, indirect or consequential including but not limited to fees and charges of engineers, architects, attorneys, consultants and other professionals and court costs arising out of or in consequence of the performance of this Agreement at all trial and appellate levels. Indemnification shall specifically include but not be limited to claims, damages, losses, liabilities and expenses arising out of or from (a) the negligent or defective design of the project and Work of this Agreement; (b) any act, omission or default of the Contractor, its subcontractors, agents, suppliers, employees or laborers; (c) any and all bodily injuries, sickness, disease or death; (d) injury to or destruction of tangible property, including any resulting loss of use; (e) other such damages, liabilities, or losses received or sustained by any person or persons during or on account of any operations connected with the construction of this Project including the warranty period; (f) the use of any improper materials; (g) any construction defect including both patent and latent defects; (h) failure to timely complete the work; (i) the violation of any federal, state, county or City laws, ordinances or regulations by Contractor, its subcontractors, agents, servants, independent contractors or employees; (j) the breach or alleged breach by Contractor of any term of the Agreement, including the breach or alleged breach of any warranty or guarantee.

12.2.2 Contractor agrees to indemnify, defend, and hold harmless the City, its officers, agents and employees, from all damages, liabilities, losses, claims, fines and fees, and from any and all suits and actions of every name and description that may be brought against City, its officers, agents and employees, on account of any claims, fees, royalties, or costs for any invention or patent and/or for the infringement of any and all copyrights or patent rights claimed by any person, firm, or corporation.

12.2.3 Contractor shall pay all claims, losses, liens, settlements or judgments of any nature in connection with the foregoing indemnifications including, but not limited to, reasonable attorney's fees and costs for trials and appeals.

12.2.4 If any subcontractor, supplier, laborer, or materialmen of Contractor or any other person directly or indirectly acting for or through Contractor files or attempts to file a mechanic's or construction lien against the real property on which the work is performed or any part or against any personal property or improvements thereon or make a claim against any monies due or to become due from the City to Contractor or from Contractor to a subcontractor, for or on account of any work, labor, services, material, equipment, or other items furnished in connection with the Work or any change order, Contractor agrees to satisfy, remove, or discharge such lien or claim at its own expense by bond, payment, or otherwise within five (5) days of the filing or from receipt of written notice from the City.

Additionally, until such time as such lien or claim is satisfied, removed or discharged by Contractor, all monies due to Contractor, or that become due to Contractor before the lien or claim is satisfied, removed or otherwise discharged, shall be held by City as security for the satisfaction, removal and discharge of such lien and any expense that may be incurred while obtaining the discharge. If Contractor shall fail to do so, City shall have the right, in addition to all other rights and remedies provided by this Agreement or by law, to satisfy, remove, or discharge such lien or claim by whatever means City chooses at the entire and sole cost and expense of Contractor which costs and expenses shall, without limitation, include attorney's fees, litigation costs, fees and expenses and all court costs and assessments, and which shall be deducted from any amount owing to Contractor. In the event the amount due Contractor is less than the amount required to satisfy Contractor's obligation under this, or any other article, paragraph or section of this Agreement, the Contractor shall be liable for the deficiency due the City.

12.2.5 The Contractor and the City agree that Section 725.06(2), Florida Statutes (2022), as may be amended or revised, controls the extent and limits of the indemnification and hold harmless provisions of this Agreement, if any, and that the Parties waive any defects in the wording of this Article that runs afoul of said statutory section.

### **ARTICLE 13 – CHANGES IN THE WORK**

- 13.1 Without invalidating this Agreement, the City may, at any time or from time-to-time order additions, deletions or revisions in the Work through the issuance of Change Orders. Upon receipt of a fully executed Change Order, the Contractor shall proceed with the Work involved. All Work shall be executed under the applicable conditions of the Contract Documents. If any Change Order causes an increase or decrease in the Contract Price or an extension or shortening of the Contract Time, an equitable adjustment will be made as provided in Article 14 or Article 15 on the basis of a claim made by either Party.
- 13.2 The Project Manager may authorize minor changes in the Work not involving an adjustment in the Contract Price or the Contract Time, which are consistent with the overall intent of the Contract Documents. Such changes must be in writing and signed by the City and the Contractor.
- 13.3 If notice of any change affecting the general scope of the Work or change in the Contract Price is required by the provisions of any Bond to be given to the Surety, it will be the Contractor's responsibility to so notify the Surety, and the amount of each applicable Bond shall be adjusted accordingly. The Contractor shall furnish proof of such adjustment to the City.

### **ARTICLE 14 – CHANGE OF CONTRACT PRICE**

Change of Contract Price, approved by City, shall be computed as follows:

14.1 Cost of the Work: The term “Cost of the Work” means the sum of all direct costs necessarily incurred and paid by Contractor in the proper performance of the Work. Except as otherwise may be agreed to in writing by the City, these costs shall be in amounts no higher than those prevailing in the City and shall include only the following items and shall not include any of the costs itemized in Paragraph 14.3:

14.1.1 Payroll costs for employees in the direct employ of the Contractor in the performance of the Work under schedules of job classifications agreed upon by the City and the Contractor. Payroll costs for employees not employed full time on the Work shall be apportioned on the basis of their time spent on the Work.

Payroll costs shall include, but not be limited to, salaries and wages plus cost of fringe benefits which shall include social security contributions, unemployment, excise and payroll taxes, worker’s compensation, health and retirement benefits, bonuses, sick leave, vacation and applicable holiday pay.

14.1.2 Cost of all materials and equipment furnished and incorporated in the Work, including costs of transportation and storage, and required suppliers and field services. All cash discounts, rebates and refunds and all returns from sale of surplus materials and equipment shall accrue to the City, and the Contractor shall make provisions so that they may be obtained.

14.1.3 Supplemental costs including the following:

14.1.3.1 Cost, including transportation and maintenance of all materials, supplies, equipment, machinery, appliances, office and temporary facilities at the site and hand tools not owned by the workers, which are consumed in the performance of the Work.

14.1.3.2 Rentals of all construction equipment and machinery and the parts whether rented from the Contractor or others in accordance with rental agreements approved by the City, and the costs of transporting, loading, unloading, installation, dismantling and removal. The rental of any such equipment, machinery or parts shall cease when the use is no longer necessary for the Work.

14.1.3.3 Sales, consumer, use or similar taxes related to the Work and for which the Contractor is liable, imposed by laws and regulations.

14.1.3.4 Royalty payments and fees for permits and licenses.

14.1.3.5 The cost of utilities, fuel and sanitary facilities at the Work site.

14.1.3.6 Minor expenses such as telegrams, long distance telephone calls, telephone service at the site, expressage and similar petty cash items in connection with the Work.

14.1.3.7 Cost of premiums for additional bonds and insurance required because of changes in the Work.

- 14.2 The Contract Price may only be increased by an approved and fully executed Change Order when Work is modified in accordance with Article 13 and approved by the City in writing. Any claim for an increase in the Contract Price resulting from a Change Order shall be based on written notice delivered to the Project Manager within ten (10) days of the occurrence of the Change Order giving rise to the claim. Notice of the amount of the claim with supporting data shall be included in the Change Order and delivered within twenty (20) days of such occurrence unless Project Manager allows an additional period of time to ascertain accurate cost data. Any change in the Contract Price resulting from any such claim shall be incorporated in the Change Order. **IT IS EXPRESSLY AND SPECIFICALLY AGREED THAT ANY AND ALL CLAIMS FOR CHANGES TO THE CONTRACT PRICE SHALL BE WAIVED IF NOT SUBMITTED IN STRICT ACCORDANCE WITH THE REQUIREMENTS OF THIS SECTION.**
- 14.3 Not Included in the Cost of the Work: The term “Cost of the Work” shall not include any of the following:
- 14.3.1 Payroll costs and other compensation of the Contractor’s officers’ executives, principals (of partnership and sole proprietorships), general managers, engineers, architects, estimators, attorneys, auditor, accountants, purchasing and contracting agents, expeditors, timekeepers, clerks and other personnel employed by the Contractor whether at the site or in the Contractor’s principal or branch office for general administration of the work and not specifically included in the agreed upon schedule of job classifications referred to in Paragraph 14.1.1, all of which are to be considered administrative costs covered by the Contractor’s fee.
  - 14.3.2 Expenses of the Contractor’s principal and branch offices other than the Contractor’s office at the site.
  - 14.3.3 Any part of the Contractor’s capital expenses, including interest on the Contractor’s capital employed for the Work and charges against the Contractor for delinquent payments.
  - 14.3.4 Cost of premiums for all bonds and for all insurance whether or not the Contractor is required by the Contract Documents to purchase and maintain the same.
  - 14.3.5 Costs due to the negligence of the Contractor, any subcontractor, or anyone directly or indirectly employed by any of them or for whose acts any of them may be liable, including but not limited to, the correction of defective Work, disposal of materials or equipment wrongly supplied and making good any damage to property.
  - 14.3.6 Other overhead or general expense costs of any kind and the costs of any item not specifically and expressly included in Paragraph 14.1.
- 14.4 Basis of Compensation: The Contractor’s compensation, allowed to the Contractor for overhead and profit, shall be determined as follows:

14.4.1 A mutually acceptable negotiated fee:

14.4.1.1 For costs incurred under Paragraphs 14.1.1 and 14.1.2, the Contractor's fee shall not exceed five percent (5%).

14.4.1.2 No fee shall be payable on the basis of costs itemized under Paragraphs 14.1.3.1, 14.1.3.2, 14.1.3.3, 14.1.3.4, 14.1.3.5, 14.1.3.6, 14.1.3.7, 14.3.1, 14.3.2, 14.3.3, 14.3.4, 14.3.5 and 14.3.6.

14.4.1.3 The amount of credit to be allowed by the Contractor to the City for any such change which results in a net decrease plus a deduction in the Contractor's fee by an amount equal to five percent (5%) for the net decrease.

14.4.1.4 When both additions and credits are involved in any one change the combined overhead and profit shall be figured on the basis of net increase if any, however, not to exceed five percent (5%) of the agreed compensation. Profit will not be paid on any Work not performed.

14.5 Cost Breakdown Required: Whenever the cost of any Work is to be determined pursuant to this Article, the Contractor will submit in form acceptable to the City an itemized cost breakdown together with supporting documentation. Whenever a change in the Work is to be based upon mutual acceptance of a lump sum, whether the amount is an addition, credit, or no-charge-in-cost, the Contractor shall submit an estimate substantiated by a complete itemized breakdown:

14.5.1 The breakdown shall list quantities and unit prices for materials, labor, equipment and other items of cost.

14.5.2 Whenever a change involves the Contractor and one (1) or more subcontractors and the change is an increase in the agreed compensation, the overhead and profit percentage for the Contractor and each subcontractor shall be itemized separately.

## **ARTICLE 15 – CHANGE OF THE CONTRACT TIME**

15.1 The Contract Time may only be changed by an approved and fully executed Change Order. Any claim for an extension in the Contract Time shall be based on written notice delivered to the Project Manager within five (5) days of the occurrence of the event giving rise to the claim. Any change in the Contract Time resulting from any such claim shall be incorporated in a Change Order.

15.2 The Contract Time will be extended in an amount equal to time lost due to delays beyond the control of the Contractor if a claim is made therefore as provided in Paragraph 15.1. Such delays shall include but not be limited to, acts or neglect by the City, or to fires, floods, labor disputes, epidemics, abnormal weather conditions, pandemics, act of Governmental Authority, state of emergency, or acts of God.

- 15.3 All time limits stated in the Contract Documents are of the essence. The provisions of this Article 15 shall not exclude recovery for damages for delay by the Contractor.
- 15.4 Delays caused by or resulting from entities, contractors or subcontractors who are not affiliated with the Contractor (non-affiliated Contractors) shall not give rise to a claim by the Contractor for damages for increases in material and/or labor costs. Such entities, contractors and subcontractors include, but are not limited to, the City's contractors and subcontractors, Florida Power and Light Company, AT&T and Florida East Coast Railway, LLC.
- 15.5 Rights of Various Interests: Whenever work being done by City's forces or by other contractors is contiguous to or within the limits of work covered by this Agreement, the respective rights of the various interests involved shall be established by the Project Manager to secure the completion of the various portions of the Work in general harmony.

#### ARTICLE 16 – LIQUIDATED DAMAGES

- 16.1 Upon failure of the Contractor to complete the Work within the time specified for completion, the Contractor shall pay to the City the sum of **One Thousand Dollars (\$1,000.00)** for each and every calendar day that the completion of the Work is delayed beyond the time specified in this Agreement for completion, as fixed and agreed liquidated damages and not as a penalty, so long as the delay is caused by the Contractor. Should an act of God or the acts or omissions of the City, its agents or representatives, in derogation to the terms of this Agreement cause the delay, the Contractor shall not be responsible for the delay nor liquidated damages. Liquidated damages are fixed and agreed upon between the Parties, recognizing the impossibility of precisely ascertaining the amount of damages that will be sustained by the City as a consequence of such delay and both Parties desiring to obviate any question of dispute concerning the amount of damages and the cost and effect of the failure of the Contractor to complete the Work on time. Liquidated damages shall apply separately to each portion of the Work for which a time of completion is given. The City shall have the right to deduct from or retain any compensation which may be due or which may become due and payable to the Contractor the amount of liquidated damages, and if the amount retained by the City is insufficient to pay in full such liquidated damages, the Contractor shall pay all liquidated damages in full. The Contractor shall be responsible for reimbursing the City, in addition to liquidated damages or other damages for delay, for all costs of engineering, architectural fees, and inspection and other costs incurred in administering the construction of the Project beyond the completion date specified or beyond an approved extension of time granted to the Contractor whichever is later. Delays caused by or resulting from entities, contractors or subcontractors who are not affiliated with the Contractor shall not give rise to a claim by Contractor for damages for increase in material and/or labor costs. Such entities, contractors and subcontractors include, but are not limited to, the City's contractors and subcontractors, Florida Power and Light Company, AT&T, and Florida East Coast Railway, LLC.
- 16.2 No Extended Damages: For other and additional good and valuable consideration the receipt and sufficiency of which is hereby acknowledged, the Contractor covenants and agrees that in the event of any delay of construction or for any reason, allegation or claim, and notwithstanding the reason of the delay, reason, claim or allegation or who



caused them or the construction delay or whether they were caused by the City, that there will be no entitlement to Contractor to or for any direct or indirect financial damages or losses for extended corporate overhead impact, extended project overhead impacts, project support services, mobilization or demobilization or by whatever other label or legal concept or theory and types of names or labels or basis such claims may have, or any business damages or losses of whatever type or nature, and Contractor hereby waives any right to make any such claim or claims. This provision will have application and effect when construction delays are anticipated and agreed upon by both the City and the Contractor.

## **ARTICLE 17 – SUSPENSION OF WORK AND TERMINATION**

- 17.1 City May Suspend Work: The City may, at any time and without cause, suspend the Work or any portion of the Work for a period of not more than ninety (90) days by notice in writing to the Contractor which shall fix the date on which Work shall be resumed. The Contractor shall resume the Work on the date fixed. The Contractor will be allowed an increase in the Contract Price or an extension of the Contract Time, or both, directly attributable to any suspension, if the Contractor makes a claim as provided in Articles 14 and 15.
- 17.2 City's Right to Terminate Contract: The City may terminate this Agreement upon fifteen (15) calendar days' written notice upon the occurrence of any one or more of the following events:
- 17.2.1 If the Contractor makes a general assignment for the benefit of creditors.
  - 17.2.2 If a trustee, receiver, custodian or agent of the Contractor is appointed under applicable law or under Agreement, whose appointment or authority to take charge of property of the Contractor is for the purpose of enforcing a lien against such property or for the purpose of general administration of such property for the benefit of the Contractor's creditors.
  - 17.2.3 If Contractor fails to begin the Work within fifteen (15) calendar days after the date set forth in the Notice to Proceed, or fails to perform the Work with sufficient workers and equipment or with sufficient materials to ensure the prompt completion of the Work, or shall perform the Work unsuitably, or cause it to be rejected as defective and unsuitable, or shall discontinue the prosecution of the Work pursuant to the accepted schedule or if Contractor shall fail to perform any material term set forth in the Contract Documents, or from any other cause whatsoever shall not carry on the Work in an acceptable manner, Project Manager may give notice in writing to Contractor and its Surety of such delay, neglect or default, specifying the same.
  - 17.2.4 If the Contractor repeatedly fails to make prompt payments to subcontractors or for labor, material or equipment.
  - 17.2.5 If the Contractor repeatedly disregards proper safety procedures.
  - 17.2.6 If the Contractor disregards any local, state or federal laws or regulations.

- 17.2.7 If the Contactor otherwise violates any provisions of this Agreement.
- 17.3 If Contractor, within a period of ten (10) calendar days after such notice, shall not proceed in accordance therewith, the City may exclude the Contractor from the Work site and take the prosecution of the Work out of the hands of the Contractor, and take possession of the Work and all of the Contractor's tools, appliances, construction equipment and machinery at the site and use them without liability to the City for trespass or conversion, incorporate in the Work all materials and equipment stored at the site or for which the City has paid the Contractor but which are stored elsewhere, and finish the Work as the City may deem expedient. In this instance, the Contractor shall not be entitled to receive any further compensation until the Work is finished.
- 17.3.1 If after notice of termination of Contractor's notice to proceed, it is determined for any reason that Contractor was not in default, the rights and obligations of City and Contractor shall be the same as if the notice of termination had been issued pursuant to the Termination for Convenience clause as set forth below in Section 17.5.
- 17.3.2 Upon receipt of Notice of Termination pursuant to Sections 17.2 or 17.5, Contractor shall promptly discontinue all affected work unless the Notice of Termination directs otherwise and deliver or otherwise make available to City all data, drawings, specifications, reports, estimates, summaries and such other information as may have been required by the Contract Documents whether completed or in process.
- 17.4 If the Contractor commits a default due to its insolvency or bankruptcy, the following shall apply:
- 17.4.1 Should this Agreement be entered into and fully executed by the Parties, funds released and the Contractor (Debtor) files for bankruptcy, the following shall occur:
- 17.4.1.1 In the event the Contactor files a voluntary petition under 11 U.S.C. 301 or 302, or an order for relief is entered under 11 U.S.C. 303, the Contractor shall acknowledge the extent, validity, and priority of the lien recorded in favor of the City. The Contractor further agrees that in the event of this default, the City shall, at its option, be entitled to seek relief from the automatic stay pursuant to 11 U.S.C. 362. The City shall be entitled to relief from the automatic stay pursuant to 11 U.S.C. 362(d) (1) or (d) (2), and the Contactor agrees to waive the notice provisions in effect pursuant to 11 U.S.C. 362 and any applicable Local Rules of the United States Bankruptcy Court. The Contactor acknowledges that such waiver is done knowingly and voluntarily.
- 17.4.1.2 Alternatively, in the event the City does not seek stay relief, or if stay relief is denied, the City shall be entitled to monthly adequate protection payments within the meaning of 11 U.S.C. 361. The monthly adequate protection payments shall each be in an amount determined in accordance with the Note and Mortgage executed by the Contractor in favor of the City.

17.4.1.3 In the event the Contractor files for bankruptcy under Chapter 13 of Title 11, United States Code in addition to the foregoing provisions, the Contractor agrees to cure any amounts in arrears over a period not to exceed twenty-four (24) months from the date of the confirmation order, and such payments shall be made in addition to the regular monthly payments required by the Note and mortgage. Additionally, the Contractor shall agree that the City is over secured and, therefore, entitled to interest and attorney's fees pursuant to 11 U.S.C. 506(b). Such fees shall be allowed and payable as an administrative expense. Further, in the event the Contractor has less than five (5) years of payments remaining on the Note, the Contractor agrees that the treatment afforded to the claim of the City under any confirmed plan of reorganization shall provide that the remaining payments shall be satisfied in accordance with the Note, and that the remaining payments or claim shall not be extended or amortized over a longer period than the time remaining under the Note.

17.4.2 Should this Agreement be entered into and fully executed by the Parties, and the funds have not been forwarded to Contractor, the following shall occur:

17.4.2.1 In the event the Contractor files a voluntary petition pursuant to 11 U.S.C. 301 or 302, or an order for relief is entered under 11 U.S.C. 303., the Contractor acknowledges that the commencement of a bankruptcy proceeding constitutes an event of default under the terms of this Agreement. Further, the Contractor acknowledges that this Agreement constitutes an executory contract within the meaning of 11 U.S.C. 365. The Contractor acknowledges that this Agreement is not capable of being assumed pursuant to 11 U.S.C. 365(c)(2), unless the City expressly consents in writing to the assumption. In the event the City consents to the assumption, the Contractor agrees to file a motion to assume this Agreement within ten (10) days after receipt of written consent from the City, regardless of whether the bankruptcy proceeding is pending under Chapter 7, 11, or 13 of Title 11 of the United States Code. The Contractor further acknowledges that this Agreement is not capable of being assigned pursuant to 11 U.S.C. 365(b)(1).

17.5 Termination for Convenience: This Agreement may be terminated for convenience in writing by City upon thirty (30) days' written notice to Contractor (delivered by certified mail, return receipt requested) of intent to terminate and the date on which such termination becomes effective. In such case, Contractor shall be paid for all work executed and accepted by the City and costs reasonably incurred by Contractor relating to commitments which had become firm prior to the termination. No payment shall be made for profit for work/services which have not been performed or accepted.

17.6 Where the Contractor's service has been so terminated by the City, the termination shall not affect any rights of the City against the Contractor then existing or which may thereafter accrue. Any retention or payment of moneys due the Contractor by the City will not release the Contractor from liability.

- 17.7 The Contractor has no right, authority or ability to terminate the Work except for the wrongful withholding of any payments due the Contractor from the City.

## **ARTICLE 18 – DISPUTE RESOLUTION**

18.1 Resolution of Disputes: Questions, claims, difficulties and disputes of whatever nature which may arise relative to the technical interpretation of the Contract Documents and fulfillment of this Agreement as to the character, quality, amount and value of any work done and materials furnished, or proposed to be done or furnished under, or by reason of, the Contract Documents which cannot be resolved by mutual agreement of City Project Manager and Contractor shall be submitted to the City Manager or his designee and Contractor's representative for resolution. Prior to any litigation being commenced, for any disputes which remain unresolved, within sixty (60) days after final completion of the Work, the Parties shall participate in mediation to address all unresolved disputes to a mediator agreed upon by the Parties. Should any objection not be resolved in mediation, the Parties retain all their legal rights and remedies provided under the laws of Florida. Failure by a Party to comply in strict accordance with the requirements of this Article, then said Party specifically waives all of its rights provided hereunder, including its rights and remedies under the laws of Florida.

18.1.1 All non-technical administrative disputes (such as billing and payment) shall be determined by Contract Administrator.

18.1.2 During the pendency of any dispute and after a determination thereof, Contractor and Contract Administrator shall act in good faith to mitigate any potential damages including utilization of construction schedule changes and alternate means of construction. During the pendency of any dispute arising under this Agreement, other than termination herein, Contractor shall carry on the Work and adhere to the progress schedule. The Work shall not be delayed or postponed pending resolution of any disputes or disagreements.

18.1.3 For any disputes which remain unsolved, within sixty (60) calendar days after Final Completion of the Work, the Parties shall participate in mediation to address all unresolved disputes. A mediator shall be mutually agreed upon by the Parties. Should any objection not be resolved in mediation, the Parties retain all their legal rights and remedies under applicable law. If a Party objecting to a determination, fails to comply in strict accordance with the requirements of this Article, said Party specifically waives all of its rights provided hereunder, including its rights and remedies under applicable law.

## **ARTICLE 19 – NOTICES**

19.1 All notices required by any of the Contract Documents shall be in writing and shall be deemed delivered upon mailing by certified mail, return receipt requested to the following:

To the City:

Justin Murray, P.E.  
Project Manager  
City of Fort Lauderdale  
1765 SE 18<sup>th</sup> Street Administration Building Main Floor  
Fort Lauderdale, FL 33316  
Telephone: (954) 828-4122  
E-mail: [jmurray@fortlauderdale.gov](mailto:jmurray@fortlauderdale.gov)

with copies to:

City Manager and City Attorney  
City of Fort Lauderdale  
100 North Andrews Avenue  
Fort Lauderdale, Florida 33301-1016

To the Contractor:

\_\_\_\_\_  
\_\_\_\_\_  
\_\_\_\_\_  
Telephone: \_\_\_\_\_  
E-mail: \_\_\_\_\_

## ARTICLE 20 – LIMITATION OF LIABILITY

- 20.1 The City desires to enter into this Agreement only if in so doing the City can place a limit on the City's liability for any cause of action arising out of this Agreement, so that the City's liability for any breach never exceeds the sum of \$1,000. For other good and valuable consideration, the receipt and sufficiency of which is hereby acknowledged, the Contractor expresses its willingness to enter into this Agreement with the knowledge that the Contractor's recovery from the City to any action or claim arising from the Agreement is limited to a maximum amount of \$1,000, which amount shall be reduced by the amount actually paid by the City to the Contractor pursuant to this Agreement, for any action or claim arising out of this Agreement. Nothing contained in this paragraph or elsewhere in this Agreement is in any way intended either to be a waiver of the limitation placed upon the City's liability as set forth in Section 768.28, Florida Statutes (2022), as may be amended or revised, or to extend the City's liability beyond the limits established in said Section 768.28, Florida Statutes (2022), as may be amended or revised; and no claim or award against the City shall include attorney's fees, investigative costs, expert fees, suit costs or pre-judgment interest.
- 20.2 No Extended Damages: For other and additional good and valuable consideration the receipt and sufficiency of which is hereby acknowledged, the Contractor covenants and agrees that in the event of any delay of construction or for any reason, allegation or claim, and notwithstanding the reason of the delay, reason, claim or allegation or who caused them or the construction delay or whether they were caused by the City, that there will be no entitlement to Contractor to or for any direct or indirect financial damages or losses for extended corporate overhead impact, extended project overhead impacts, project support services, mobilization or demobilization or by whatever other label or

legal concept or theory and types of names or labels or basis such claims may have, or any business damages or losses of whatever type or nature, and Contractor hereby waives any right to make any such claim or claims. This provision will have application and effect when construction delays are anticipated and agreed upon by both the City and the Contractor.

## **ARTICLE 21 – GOVERNING LAW; WAIVER OF JURY TRIAL**

- 21.1 The Agreement shall be interpreted and construed in accordance with, and governed by, the laws of the state of Florida. The Parties agree that the exclusive venue for any lawsuit arising from, related to, or in connection with this Agreement shall be in the state courts of the Seventeenth Judicial Circuit in and for Broward County, Florida. If any claims arising from, related to, or in connection with this Agreement must be litigated in federal court, the Parties agree that the exclusive venue for any such lawsuit shall be in the United States District Court or United States Bankruptcy Court for the Southern District of Florida. **BY ENTERING INTO THIS AGREEMENT, THE PARTIES HEREBY EXPRESSLY WAIVE ANY AND ALL RIGHTS EITHER PARTY MIGHT HAVE TO A TRIAL BY JURY OF ANY ISSUES RELATED TO THIS AGREEMENT. IF A PARTY FAILS TO WITHDRAW A REQUEST FOR A JURY TRIAL IN A LAWSUIT ARISING OUT OF THIS AGREEMENT AFTER WRITTEN NOTICE BY THE OTHER PARTY OF VIOLATION OF THIS SECTION, THE PARTY MAKING THE REQUEST FOR JURY TRIAL SHALL BE LIABLE FOR THE REASONABLE ATTORNEYS' FEES AND COSTS OF THE OTHER PARTY IN CONTESTING THE REQUEST FOR JURY TRIAL, AND SUCH AMOUNTS SHALL BE AWARDED BY THE COURT IN ADJUDICATING THE MOTION.**

## **ARTICLE 22 – MISCELLANEOUS**

- 22.1 The duties and obligations imposed by this Agreement and the rights and remedies available to the Parties and, in particular but without limitation, the warranties, guaranties and obligations imposed upon the Contractor and all of the rights and remedies available to the City, are in addition to, and are not to be construed in any way as a limitation of, any rights and remedies available to any or all of them which are otherwise imposed or available by laws or regulations, by special warranty or guarantee or by other provisions of the Contract Documents, and the provisions of this Paragraph will be as effective as if repeated specifically in the Contract Documents, and the provisions of this Paragraph will survive final payment and termination or completion of this Agreement.
- 22.2 The Contractor shall not assign or transfer this Agreement or its rights, title or interests. The obligations undertaken by the Contractor pursuant to this Agreement shall not be delegated or assigned to any other person or firm. Violation of the terms of this Paragraph shall constitute a material breach of Agreement by the Contractor and the City any, at its discretion, cancel this Agreement and all rights, title and interest of the Contractor which shall immediately cease and terminate.
- 22.3 The Contractor and its employees, volunteers and agents shall be and remain as independent contractor and not agents or employees of the City with respect to all of the

acts and services performed by and under the terms of this Agreement. This Agreement shall not in any way be constructed to create a partnership, association or any other kind of joint undertaking or venture between the Parties.

- 22.4 The City reserves the right to audit the records of the Contractor relating in any way to the Work to be performed pursuant to this Agreement at any time during the performance and term of this Agreement and for a period of three (3) years after completion and acceptance by the City. If required by the City, the Contractor agrees to submit to an audit by an independent certified public accountant selected by the City. The Contractor shall allow the City to inspect, examine and review the records of the Contractor at any and all times during normal business hours during the term of this Agreement.
- 22.5 The remedies expressly provided in this Agreement to the City shall not be deemed to be exclusive but shall be cumulative and in addition to all other remedies in favor of the City now or later existing at law or in equity.
- 22.6 Should any part, term or provisions of this Agreement be decided by the courts to be invalid, illegal or in conflict with any state or federal law, the validity of the remaining portion or provision shall not be affected.
- 22.7 Prohibition Against Contracting With Scrutinized Companies: Subject to *Odebrecht Construction, Inc., v. Prasad*, 876 F.Supp.2d 1305 (S.D. Fla. 2012), *affirmed*, *Odebrecht Construction, Inc., v. Secretary, Florida Department of Transportation*, 715 F.3d 1268 (11th Cir. 2013), with regard to the “Cuba Amendment,” the Contractor certifies that it is not on the Scrutinized Companies with Activities in Sudan List or the Scrutinized Companies with Activities in the Iran Petroleum Energy Sector List, and that it does not have business operations in Cuba or Syria, as provided in Section 287.135, Florida Statutes (2022), as may be amended or revised. The Contractor certifies that it is not on the Scrutinized Companies that Boycott Israel List created pursuant to Section 215.4725, Florida Statutes (2022), as may be amended or revised, and that it is not engaged in a boycott of Israel. The City may terminate this Agreement at the City’s option if the Contractor is found to have submitted a false certification as provided under subsection (5) of Section 287.135, Florida Statutes (2022), as may be amended or revised, or been placed on the Scrutinized Companies with Activities in Sudan List or the Scrutinized Companies with Activities in the Iran Petroleum Energy Sector List or the Scrutinized Companies that Boycott Israel List created pursuant to Section 215.4725, Florida Statutes (2022), as may be amended or revised, or is engaged in a boycott of Israel or has been engaged in business operations in Cuba or Syria, as defined in Section 287.135, Florida Statutes (2022), as may be amended or revised.

By submitting a bid or response, the company, principals, or owners certify that it is not listed on the Scrutinized Companies with Activities in Sudan List or listed on the Scrutinized Companies with Activities in the Iran Petroleum Energy Sector List or is engaged in business operations in Cuba or Syria.

- 22.8 Public Entity Crimes: In accordance with the Public Crimes Act, Section 287.133, Florida Statutes (2022), as may be amended or revised, a person or affiliate who is a contractor, consultant or other provider, who has been placed on the convicted vendor list following a conviction for a public entity crime may not submit a bid on a contract to

provide any goods or services to the City, may not submit a bid on a contract with the City for the construction or repair of a public building or public work, may not submit bids on leases of real property to the City, may not be awarded or perform work as a contractor, supplier, subcontractor, or consultant under a contract with the City, and may not transact any business with the City in excess of the threshold amount provided in Section 287.017, Florida Statutes (2022), as may be amended or revised, for category two purchases for a period of thirty-six (36) months from the date of being placed on the convicted vendor list. Violation of this section by Contractor shall result in cancellation of the City purchase and may result in Contractor debarment.

22.9 Attorney Fees: If City or Contractor incurs any expense in enforcing the terms of this Agreement through litigation, the prevailing Party in that litigation shall be reimbursed for all such costs and expenses, including but not limited to court costs, and reasonable attorney fees incurred during litigation.

#### 22.10 Public Records

**IF THE CONTRACTOR HAS QUESTIONS REGARDING THE APPLICATION OF CHAPTER 119, FLORIDA STATUTES (2022), TO THE CONTRACTOR'S DUTY TO PROVIDE PUBLIC RECORDS RELATING TO THIS AGREEMENT, CONTACT THE CUSTODIAN OF PUBLIC RECORDS AT [PRRCONTRACT@FORTLAUDERDALE.GOV](mailto:PRRCONTRACT@FORTLAUDERDALE.GOV), 954-828-5002, CITY CLERK'S OFFICE, 100 N. ANDREWS AVENUE, FORT LAUDERDALE, FLORIDA 33301.**

Contractor shall:

1. Keep and maintain public records required by the City in order to perform the service.
2. Upon request from the City's custodian of public records, provide the City with a copy of the requested records or allow the records to be inspected or copied within a reasonable time at a cost that does not exceed the cost provided in Chapter 119, Florida Statutes (2022), as may be amended or revised, or as otherwise provided by law.
3. Ensure that public records that are exempt or confidential and exempt from public records disclosure requirements are not disclosed except as authorized by law for the duration of the contract term and following completion of this Agreement if the Contractor does not transfer the records to the City.
4. Upon completion of the Agreement, transfer, at no cost, to the City all public records in possession of the Contractor or keep and maintain public records required by the City to perform the service. If the Contractor transfers all public records to the City upon completion of this Agreement, the Contractor shall destroy any duplicate public records that are exempt or confidential and exempt from public records disclosure requirements. If the Contractor keeps and maintains public records upon completion of this Agreement, the Contractor shall meet all applicable requirements for retaining public records. All records stored electronically must be provided to the City, upon



request from the City's custodian of public records, in a format that is compatible with the information technology systems of the City.

#### 22.11 Non-Discrimination

The Contractor shall not discriminate against its employees based on the employee's race, color, religion, gender, gender identity, gender expression, marital status, sexual orientation, national origin, age, disability, or any other protected classification as defined by applicable law.

1. The Contractor certifies and represents that the Contractor offers the same health benefits to the domestic partners of its employees as are offered its employees' spouses or offers its employees the cash equivalent of such health benefits because it is unable to provide health benefits to its employees' domestic partners, and that the Contractor will comply with Section 2-187, Code of Ordinances of the City of Fort Lauderdale, Florida, as may be amended or revised, ("Section 2-187"), during the entire term of this Agreement.
2. The failure of the Contractor to comply with Section 2-187 shall be deemed to be a material breach of this Agreement, entitling the City to pursue any remedy stated below or any remedy provided under applicable law.
3. The City may terminate this Agreement if the Contractor fails to comply with Section 2-187.
4. The City may retain all monies due or to become due until the Contractor complies with Section 2-187.
5. The Contractor may be subject to debarment or suspension proceedings. Such proceedings will be consistent with the procedures in Section 2-183 of the Code of Ordinances of the City of Fort Lauderdale, Florida.

#### 22.12 E-Verify

As a condition precedent to the effectiveness of this Agreement, pursuant to Section 448.095, Florida Statutes (2023), as may be amended or revised, the Contractor and its subcontractors shall register with and use the E-Verify system to electronically verify the employment eligibility of newly hired employees.

1. The Contractor shall require each of its subcontractors, if any, to provide the Contractor with an affidavit stating that the subcontractor does not employ, contract with, or subcontract with an unauthorized alien. The Contractor shall maintain a copy of the subcontractor's affidavit for the duration of this Agreement and in accordance with the public records requirements of this Agreement.
2. The City, the Contractor, or any subcontractor who has a good faith belief that a person or entity with which it is contracting has knowingly violated Subsection 448.09(1), Florida Statutes (2023), as may be amended or revised, shall terminate the contract with the person or entity.

3. The City, upon good faith belief that a subcontractor knowingly violated the provisions of Subsection 448.095(5), Florida Statutes (2023), as may be amended or revised, but that the Contractor otherwise complied with Subsection 448.095(5), Florida Statutes (2023), as may be amended or revised, shall promptly notify Contractor and order the Contractor to immediately terminate the contract with the subcontractor, and the Contractor shall comply with such order.

4. A contract terminated under Subparagraph 448.095(5)(c)1. or 2., Florida Statutes (2023), as may be amended or revised, is not a breach of contract and may not be considered as such. If the City terminates this contract under Paragraph 448.095(5)(c), Florida Statutes (2023), as may be amended or revised, the Contractor may not be awarded a public contract for at least one year after the date on which the contract was terminated. The Contractor is liable for any additional costs incurred by the City as a result of termination of this Agreement.

5. Contractor shall include in each of its subcontracts, if any, the requirements set forth in this Section, including this subparagraph, requiring any and all subcontractors, as defined in Subsection 448.095(1)(e), Florida Statutes (2023), as may be amended or revised, to include all of the requirements of this Section in their subcontracts. Contractor shall be responsible for compliance by any and all subcontractors, as defined in Subsection 448.095(1)(e), Florida Statutes (2023), as may be amended or revised, with the requirements of Section 448.095, Florida Statutes (2023), as may be amended or revised.

**[THIS SPACE WAS INTENTIONALLY LEFT BLANK]**

CITY

IN WITNESS OF THE FOREGOING, the Parties have set their hands and seals the day and year first written above.

CITY OF FORT LAUDERDALE, a Florida municipal corporation

By: \_\_\_\_\_  
GREG CHAVARRIA  
City Manager

Date: \_\_\_\_\_

ATTEST:

By: \_\_\_\_\_  
DAVID R. SOLOMAN  
City Clerk

Approved as to Legal Form and correctness:  
D'Wayne M. Spence, Interim City Attorney

By: \_\_\_\_\_  
RHONDA MONTOYA HASAN  
Assistant City Attorney

**CONTRACTOR**

WITNESSES:

CONTRACTOR.,  
a Florida company/corporation.

\_\_\_\_\_

By: \_\_\_\_\_

\_\_\_\_\_  
Print Name

Print Name: \_\_\_\_\_

Title: \_\_\_\_\_

ATTEST:

\_\_\_\_\_

\_\_\_\_\_  
Print Name

By: \_\_\_\_\_

Secretary

(CORPORATE SEAL)

STATE OF \_\_\_\_\_:

COUNTY OF \_\_\_\_\_:

The foregoing instrument was acknowledged before me by means of  physical presence or  online notarization, this \_\_\_\_ day of \_\_\_\_\_, 2023, by \_\_\_\_\_, (NAME OF AUTHORIZED OFFICER) as \_\_\_\_\_ (TITLE OF AUTHORIZED OFFICER), for \_\_\_\_\_ (NAME OF COMPANY), a Florida \_\_\_\_\_ (TYPE OF COMPANY).

\_\_\_\_\_  
(Signature of Notary Public - State of Florida)

\_\_\_\_\_  
(Print, Type, or Stamp Commissioned Name of Notary Public)

Personally Known \_\_\_\_\_ OR Produced Identification \_\_\_\_\_  
Type of Identification Produced: \_\_\_\_\_

SECTION 011101  
SUMMARY OF WORK

PART 1 GENERAL

1.01 LOCATION OF WORK

- A. All of the Work of this Contract is located in easements, rights-of-way, or on property owned by the City of Fort Lauderdale.

1.02 WORK COVERED BY CONTRACT DOCUMENTS

- A. The completed Work will provide the City with a demonstration of mechanical integrity for each of the five (5) existing Class I injection wells just south of the George T. Lohmeyer Wastewater Treatment Plant at 1000 SE 21 Street, Fort Lauderdale, Florida. The project consists of furnishing all labor, materials and equipment to perform mechanical integrity testing (MIT) of five (5) existing Class I injection wells. The Injection Wells have a 24-inch outside diameter (OD), 0.500-inch wall thickness injection casing set to total depths of 2,800 to 2,820 feet below land surface (bls) and were constructed with a nominal 22-inch diameter open borehole extending from the bottom of the casing to approximately 3,305 to 4,010 feet bls. The Work to perform the MIT at each injection well includes but is not limited to:

1. Contractor shall take only one injection well offline at a time and pump clear water into the well to prepare for the video survey. Notify FDEP prior to beginning the MIT activities. Note: A well is not to be taken out of service during precipitation days.
2. Contractor shall perform well video surveys documenting conditions prior to and after brushing the casing interior.

Note: An injectivity test will be conducted by the City prior to cleaning and again following the cleaning.

3. Contractor shall perform cleaning of casing interior using casing brush.
4. Contractor shall grab a sample from the casing brush after cleaning has been completed.
5. Contractor shall perform a casing pressure test.
6. Contractor shall perform temperature logging and background gamma ray logging.
7. Contractor shall perform a Radioactive Tracer Survey (RTS).
8. Contractor shall furnish and install replacement wellhead hardware (316 stainless steel nuts/bolts, galvanic protection, gaskets).
9. Contractor shall comply with plant security restrictions.
10. Contractor shall prepare surfaces and paint wellhead pipes, fittings and valves.
11. Contractor shall perform site cleanup after completion of MIT activities.

12. Contractor shall furnish and install all associated and appurtenant items and perform work as specified herein and required by the City and delineated in the Contract.
- B. The completed Work will provide the Owner with the repair of the 30-inch diameter above ground concrete collars surrounding the Prestressed Concrete Cylinder Pipe (PCCP) effluent force main sections near each injection well. The Work includes, but is not limited to, the following project components:
1. Contractor shall provide all materials, labor, and equipment to repair the above ground concrete collars of the 30-inch diameter PCCP effluent force main at each well. Each above ground concrete collar segment shall be repaired as depicted on the project figures.
  2. Contractor shall coordinate with the George T. Lohmeyer Wastewater Treatment Plant Operator for the closing of all necessary valves on the 30-inch diameter force main piping, and temporarily seat leaking isolation valves.
  3. Contractor shall provide all materials, labor, and equipment to install new flange by grooved end piping and coupling, pipe, fittings, valves, and air release valves as depicted on the project figures.
  4. Contractor shall clean and pressure-test the newly installed pipe segments.
  5. Contractor shall be responsible for all material, labor, and equipment necessary to transport materials and equipment to the project site to complete the Work.
  6. SSPC-6 sand blast rust areas and paint existing above grade pipe, fittings, and accessories as depicted on the figures.
- C. The Contractor shall perform the work complete, in place, and ready for continuous service, and shall include repairs, testing, permits, cleanup, replacements and restoration required to restore the areas disturbed by construction to a condition similar to what existed prior to the starting of the Work.
- D. It is the intent of the City to obtain a complete functional, and satisfactory installation under this project, and any items of labor, equipment or materials which may be reasonably assumed as necessary to accomplish this end shall be supplied whether or not they are specifically shown on any plans which may be supplied or stated herein. The Contractor shall provide all materials for the project unless they are specifically called out in these specifications as being supplied by the City. The Contractor shall also supply all sheeting, shoring, bracing and all other labor, material or equipment required to preclude damage to, or loss of functionality of, any existing facility or system. The Contractor must use two backflow preventers when using water from hydrant.
- E. The Contractor is alerted that various "Standards" are used herein for reference and criteria and that he should obtain copies for his general use and protection. Abbreviated titles are used throughout these Specifications and although most of them are widely known, their complete titles are given below in order to avoid any misunderstanding.

AASHTO	American Association of State Highway and
Transportation Officials ACI	American Concrete Institute
AISC	American Institute of Steel Construction

AISI	American Iron and Steel Institute
ANSI	American National Standards Institute ASTM American Society of Testing and Materials ASME American Society of Mechanical Engineers AWSC American Welding Society Code
AWWA	American Water Works Association CRSI Concrete Reinforcing Steel Institute
CS	Commercial Standards-U.S. Dept. of Commerce FDEP Florida Department of Environmental Protection DOT Department of Transportation-State of Florida
FS	Federal Specifications
FBC	Florida Building Code
ISO	International Organization for Standardization
NBFU	National Board of Fire Underwriters
NBS	National Bureau of Standards-U.S. Dept. of Commerce
NSF	National Sanitation Foundation
OSHA	Occupational Safety & Health Act
PCA	Portland Cement Association
SFWMMD	South Florida Water Management District SPR Simplified Practice Recommendations
UL	Underwriters Laboratories, Inc.

1. The above list shall not be considered complete, as there are other "Standards" used; however, in most cases complete titles have been given.
2. Wherever "Standards" are indicated herein for reference, the referenced portion shall have the same force and effect as if it were included herein in its entirety, latest revision if date of publication not shown.

- F. The Contractor shall comply with all municipal, county, state, federal, and other codes which are applicable to the proposed construction work. This includes but is not limited to provisions under the Florida Department of Environment Protection (FDEP), Florida Department of Transportation (FDOT), Broward County Environmental Protection and Growth Management Division, Broward County Environmental Engineering and Permitting Division (BCEEPD), FEC Railroad, US Army Corps of Engineers, and US Coast Guard.

#### 1.03 WORK NOT COVERED BY CONTRACT

- A. Not applicable.

#### 1.04 OWNER-FURNISHED ITEMS

- A. Mechanical Integrity Test Plan and Milestone Dates

1. FDEP UIC Operating Permit for Class I Injection Wells IW-1, IW-2, IW-3 IW-4 and IW-5

#### 1.05 PERMITS

- A. Upon Notice of Award, the Contractor shall immediately apply for necessary permits from pertinent regulatory agencies. No testing shall begin until the necessary permits and approvals have been obtained.
- B. The Contractor shall familiarize himself with, and comply with, all requirements of these permits. The Contractor shall obtain all other necessary permits.
- C. The Contractor's particular attention is called to any Special Conditions of the permits relating to special testing requirements, disposal of hazardous materials, and all other general and special conditions. In the event any of the conditions of the permits are in conflict with the requirements of these Specifications, the more stringent conditions of the permits shall take precedence.
- D. Any deviations from the Specifications or permits appended thereto; must first be approved by the Engineer, even if approval for the change has been given by the permitting agency.
- E. The Contractor shall assume throughout the life of the Contract all obligations and responsibilities imposed on the City as permittee of the above-mentioned permits. All expenses necessary for compliance with the regulations and requirements of each permitting agency and its permit shall be paid by the Contractor and shall be included in his overall bid price allowance.
- F. The cost of any fees such as impact fees, inspection fees, etc. and the cost of obtaining all required permits shall be borne by the City. The Contractor shall pay the required fees, obtain the permit(s) and then upon submission of proof of cost to the City, be reimbursed for said cost out of the Approved Allowance Permit Fee Reimbursement item. This shall apply only to required permits and fees. Permits obtained or fees paid for the advantage of the Contractor or non-required permits obtained for whatever reason shall not be reimbursed. The necessity or non-necessity of a permit or fee shall be determined by the Engineer whose word shall be final. As specified in the paragraph above, all costs of compliance with the permit(s) shall be borne by the Contractor and included in his bid price. It shall be the Contractor's responsibility to secure all permits not specified herein that are required to initiate and complete the Work under this contract, except permits obtained by the City.

#### 1.06 CONTRACTOR'S AND DRILLER'S QUALIFICATIONS

- A. Award of this Contract will be made to the responsive, responsible bidder who submits an offer on all items listed in the Solicitation and whose offer represent the lowest price when all items are added in the aggregate. If a bidder fails to submit an offer on all items, its overall offer will be rejected. The City will award the total Contract to a single Contractor who has complied with these requirements.
- B. In order to aid the City in making an award of the Contract, the Bidder shall submit, with his Offer, written evidence of its qualifications and ability to begin construction, to perform in a satisfactory manner, and to complete all of the work covered by the Contract within the time specified in the Solicitation. Bidder shall submit proof of at least three similar projects within



the past 5 years involving testing of Floridan Aquifer wells and/or UIC permitted injection wells of 24-inch OD casing and to a depth of at least 2,500 feet below land surface. Specialized testing activities including coring, inflatable packer testing, mechanical integrity testing, cement bond logging, temperature logging and water quality sampling must have been completed to demonstrate relevant experience. Failure to submit this information with the bid may be cause for the Bidder to be deemed non-responsive.

- C. The bidder shall submit, among other things, the name the proposed superintendent (specifically), driller, logger, and detailed information identifying all personnel to be utilized on this project and written evidence with respect to the following:
1. The bidder has a trained and competent organization which has done work of similar character and value.
  2. The bidder will have available to do the work at the proper time or times, adequate equipment and facilities, listing such equipment and facilities in such detail that they can be quickly and accurately checked.
  3. The bidder has sufficient repair parts and supplies to maintain all equipment and facilities properly and with a minimum of delay.
  4. The bidder has experience in drilling in the geologic formations of South Florida penetrated by City's wells; including depth greater than 2,500 feet below land surface.
  5. The bidder has experience in working with wells under the high artesian pressures that will be encountered in the wells in South Florida.
  6. The Geophysical Contractor holds a valid State of Florida Water Well Contractor License issued by the South Florida Water Management District.
  7. The bidder holds a license from the Florida HRS Bureau of Radiation Control for the required geophysical logging that will be performed under this Contract.
  8. The logging vehicle is licensed by the Florida Department of Transportation for the of radioactive materials.
  9. The driver of the logging vehicle has a Commercial Driver's License with an "H" endorsement for radioactive materials.
- D. Chapter 489 of the Florida Statutes, and the rules of the State of Florida Department of Professional Regulation shall govern the qualification for Contractors and subcontractors. No Contractor or subcontractor shall be required to possess any other professional designation or affiliation in order to be eligible to bid on this project, except those stated in this solicitation. Unless prohibited by law, nothing shall prevent the City from requiring proof of sufficient expertise and skill to qualify for the subject project.
- E. Bidders are directed to PART 3 of this section, Article 3.02, for more information and additional submittals required for this Solicitation. Bidders shall submit to the Engineer the following information as part of the bid package, but not limited to, references, resumes, list of equipment, list of subcontractors, and other information required by this solicitation.

## 1.07 EQUIPMENT REQUIREMENTS

- A. Equipment will not be furnished by the City under this Contract. All material, labor and equipment necessary for completion of the work shall be furnished by the Contractor.
- B. The work shall be performed by a competent crew with equipment that is adequate to complete all phases of the testing and instruments of sufficient accuracy and resolution to identify anomalous responses to the tests. If the Contractor's equipment is not capable of satisfactorily performing the work provided for in these specifications, the Contractor at his own expense shall substitute equipment.
- C. The Contractor's equipment shall be clean and well maintained and in good operating condition when delivered to the site and during the entire operation.
- D. All equipment shall be provided with safety devices as required by governmental authorities having jurisdiction.
- E. The Contractor's equipment must be in first class operating condition, including proper mufflers and other silencing accessories. All equipment must be properly lubricated on a special maintenance type schedule to reduce noise, including tracks, rollers, idlers, sheaves and other noise producing components. Care must be taken to prevent oil spillage of any kind or oil dripping from equipment. If the equipment used proves less than satisfactory, in the opinion of the Engineer, he will have the right to order the Contractor to immediately modify the equipment to make it satisfactory, or to change to other equipment that is satisfactory at no additional cost to the City.
- F. The Contractor must use either a continuous tube or conventional drill rig to clean the casing and position and set the packer. The Contractor must have a suitable blow-off protection device for each wellbeing worked. The equipment must be of adequate size and of suitable design to accomplish the required tasks. The Contractor must also provide a crane or other lifting devices of sufficient size to support any devices and the disassembled wellhead. The pressure gauge for the documentation of mechanical integrity shall be a Heise Model CMM-12, 0-300 psig, or approved equal, and shall be calibrated by a local testing laboratory within 6 months, approved by the Engineer using a dead weight test and shall be certified. All equipment must be properly lubricated on a special maintenance type schedule to reduce noise and limit noise from impacting neighbors.
- G. The Contractor shall also have sufficient devices, stand pipes, pack-offs and related equipment to perform the tasks in an efficient manner. The television and video equipment shall be capable of high-quality DVD format in color.

## 1.08 OPERATING REQUIREMENTS

- A. All work shall comply with the City's ISO 14001 checklist and be in full conformance with the approved Mechanical Integrity Test Plan submitted to FDEP together with subsequent response letters for the injection wells at the G.T. Lohmeyer Wastewater Treatment Plant deep well field and with the appropriate sections of Chapter 62-528 FAC.
- B. The Contractor shall carefully coordinate his activities with the City to minimize interference with any existing operations or the operations of the City's G.T. Lohmeyer WWTP. City forces will isolate the well and turn over to the Contractor testing. Existing valves shall only be

operated by City personnel. The Contractor's personnel, under no circumstances, shall operate any such valve. Additionally, the City's fueling stations must not be blocked.

- C. The Contractor shall provide all barricades and/or flashing warning lights necessary to warn workers and employees of the testing throughout the Project. This shall be done at the Contractor's expense and to the satisfaction of the Engineer. Every effort must be made to reduce inconvenience and nuisances to a minimum.
- D. The Contractor shall at all times, use the main entrance to the Injection Wells site to bring in materials, equipment etc. required for the Project. Materials and equipment shall be stored in areas designated by the City's WWTP operations staff and shall not interfere with the daily operations at the site or with other Projects. Suitable platforms shall be used for material storage to prevent damage to the landscaping.
- E. The Contractor shall exercise extreme caution when transporting equipment or materials within the Injection Wells area. The conveying vehicles shall be properly selected, and equipped, to prevent damage to paved areas, landscaping and other existing facilities including wells, well pads, fencing, underground pipelines, pipe chases, etc. If necessary, suitable wooden skids shall be used to distribute loads, and to prevent damage.
- F. If any of the above existing structures, including the wells, or any other parts of the project area, are damaged, the Contractor shall make suitable repairs or replacement at his expense, in a manner described by the Engineer, and to his satisfaction.
- G. It is essential that salty or brackish water of effluent produced from any source during testing operations is prevented from contaminating the shallow aquifer, which may contain fresh water. Any water produced during testing shall be confined to the drilling pads. The testing will be accomplished using systems designed and constructed so that under no conditions shall there be an overflow. The Contractor shall be required to take all necessary steps to prevent accidental spillages from occurring. The County and FDEP may charge the Contractor for any cost incurred or penalties imposed on the City as a result of such spillage.
- H. The Contractor shall provide all facilities, equipment and materials required for the removal of waste fluids from the well site.
- I. Storage Areas – Storage areas shall be provided within the designated testing area. Responsibility for protection and safekeeping of equipment and materials at or near the sites will be solely that of the Contractor and no claim shall be made against the Owner by reasons of any act of an employee or trespasser. The Contractor shall coordinate with the Owner in selection of storage areas not likely to impede other activities on the site. Should an occasion arise necessitating access to an area occupied by stored equipment and/or materials, the Contractor shall immediately move the stored material. No equipment or materials shall be placed upon the Owner's property until approval has been received from the Owner. Upon completion of the Contract, the Contractor shall remove from the storage areas all of their equipment, temporary fencing, surplus materials, rubbish, etc., and restore the area as designated by the Owner.
- J. Erosion Abatement and Water Pollution – It is imperative that any Contractor activities, including tests requiring the pumping of water, do not contaminate or disturb the environment of the properties adjacent to the work. The Contractor shall, therefore, schedule and control his operations to confine all runoff water from disturbed surfaces. Water from operations that

becomes contaminated with lime, silt, muck, and other deleterious matter, fuels, oils, bitumens, chemicals, and other polluting materials shall be disposed of in an environmentally safe manner.

- K. Security – The Contractor shall care for and protect against loss or damage of all material to be incorporated in the construction for the duration of the Project and shall repair or replace damaged or lost materials and damage to structures and equipment.
- L. Work schedule – The work schedule will be from 8:00 a.m. to 5:00 p.m. Monday through Friday excluding holidays. Once Contractor mobilization to the site has been completed, work will be done on consecutive days, exclusive of weekends and holidays until the project is completed.

#### 1.09 CREW REQUIREMENTS

- A. The Contractor shall have not less than 5 years' experience in constructing and testing wells and shall have tested not less than 3 wells of similar type and capacity.
- B. The Contractor shall comply with the OSHA regulations contained in 29CFR Section 1910 for General Industry Regulations and 29CFR Section 1926 for Construction Regulations.

#### 1.10 REQUIRED REPORTS FROM THE CONTRACTOR

- A. The Contractor shall furnish three field copies of each geophysical log of the well on the same day the logs are run on completion of well testing. Logs shall be in a clear, concise form meeting the approval of the Engineer. The pressure testing of the casing shall be documented by a recording pressure chart and a log with the pressure recorded every ten minutes for one hour. Any deviations from the schedule shall be noted. Furnish three digital/electronic copies via portable USB flash drive.
- B. The video television surveys shall be recorded digitally and subsequently submitted on portable USB flash drives (three copies), certified free of viruses. The Contractor shall furnish the City three field copies of each video television survey of the well on the same day the well is surveyed after the completion of the survey.
- C. The results of the RTS and the Television survey will be submitted to the FDEP. It is anticipated that there will be members of the FDEP witnessing components of the testing and their input will be solicited by the Engineer. Note: FDEP must be notified three (3) working days in advance. The results of these procedures must satisfy F.A.C. FDEP Chapter 62-528 requirements for Mechanical Integrity Testing. Copies of all testing must be provided in the amount required by FDEP. Well testing superintendent shall maintain complete and current logs and daily notes for the testing of the well.

#### 1.11 SAFETY REQUIREMENTS

- A. The Contractor shall be in compliance with all applicable provisions of the Occupational Safety and Health Act of 1970. The Contractor's Manual of Safety Practices, dealing with the firm's policies on field safety procedures for employees shall be submitted to the City for review before "Notice to Proceed" will be issued.

- B. The Contractor shall conduct his operations in such a manner (utilizing warning devices, such as traffic cones, barricades and warning lights) that the public and employees of the City are given adequate warning of hazards of the work site as may be deemed necessary.
- C. The Contractor's personnel may be in the vicinity of raw sewage. For his own protection, as well as for his employees, he shall check with the City's Public Works Utilities Department, and based on their recommendation, shall have his personnel properly immunized against disease.

#### 1.12 WATER USE DURING CONSTRUCTION AND TESTING

- A. The City will furnish water for general construction free of charge from fire hydrants on the site where available. However, all water must be metered through a City meter and two reduced pressure zone (RPZ) backflow prevention device must be installed in series. Failure of the contractor to meter the water, or providing others with water, could result in his being fined and/or a citation being issued against him in accordance with the rules and regulations of the City's Tampering Section. Failure of the contractor to install the RPZ device could result in contamination of the City's potable water supply and result in the Contractor being fined and/or citations being issued against him by environmental regulatory agencies.
- B. The Contractor can obtain the temporary meter through proper application and payment of deposit fee at the City's Bulk water used for construction, flushing pipelines, and testing shall be obtained from fire hydrants. Contractor shall make payment for hydrant meter at Treasury Billing Office, 1st Floor, City Hall, 100 N. Andrews Avenue. With the paid receipt, contractor can pick up hydrant meter at the utility location office. No connection shall be made to a fire hydrant without a meter connected. The deposit fee will be refunded to the Contractor upon the return of the meter in a sound, satisfactory condition.
- C. All water necessary shall be furnished by the Contractor from an approved source. Under no circumstance shall the Contractor utilize a water source until such source has been approved for use by the Engineer.
- D. All temporary piping, valves, hoses, equipment and other items required for handling water shall be furnished by the Contractor.

#### 1.13 HURRICANE PREPAREDNESS

- A. General: During such periods of time as are designated by the United States Weather Bureau as being a hurricane alert, the Contractor shall perform all precautions as necessary to safeguard the work and property, including the removal of all small equipment and materials from the site, lashing all other equipment and materials to each other and to rigid construction, and any other safety measures as may be directed by the Engineer.
- B. Upon Notification of a Hurricane Watch: Contractor should reassemble all deep wells and remove all equipment and plan to return within 24 hours after Watch is lifted if no impact, or within 72 hours of a hurricane impact to the site and after FDEP has been notified. Provide formal notification to all Contractors to prepare and submit for approval a Plan of Action for the specific actions to be taken on their particular projects.

1.14 COORDINATION WITH THE CITY AND OTHER CONTRACTORS

- A. The City reserves the right to enter upon, and to use, any and all portions of the work performed hereunder (or under its other Contracts), whether completed or not as may be required.
- B. In no event will this Contractor be permitted to block the work area of other Contractors with equipment or materials, unless otherwise permitted by the City.
- C. Construct Project in an orderly and progressive fashion as specified in Section 3.03 - Sequence of Work, so that other Contractors can continue their work, also in an orderly and progressive manner as planned.
- D. Be responsible for coordinating the work with that of other Contractors, and for cooperating with them, and with the City, to the fullest extent.
- E. The City will act as mediator in all cases of conflict and dispute involving the Work, or scheduling of the Work, under the various Contracts, and his decision concerning the disposition of each such conflict or dispute shall be final and binding on all parties involved.
- F. The Contractor shall coordinate with the City and Plant Maintenance forces to avoid disruption of the Wastewater Treatment Plant's operation. Any charges and or penalties for impact to the Plant's operation caused by negligence or neglect of the Contractor of this project shall be withheld from payments.

1.15 WELL ACCEPTANCE CRITERIA

- A. After testing activities are completed, the Contractor shall restore the injection well back to the condition it was in prior to the initiation of testing.
- B. The Owner may withhold part of payment to the Contractor if Section 1.10 above is not completed.

1.16 REMEDIAL WORK

- A. If remedial work or re-testing is required prior to final acceptance of the work to meet regulatory requirements and the specifications of the Contract Documents due to defective materials, accident, loss of equipment or equipment malfunction, or for any other cause directly attributable to the Contractor's actions, the Contractor shall bear the entire cost of the remediation or re-testing, including all additional materials, labor, and equipment required and any necessary additional Engineering costs. In the event of a problem, the Engineer shall be notified immediately, and the following shall apply:
  - 1. The Contractor shall propose a method of correcting the problem, in writing, to the Owner. The Consultant and Owner shall review the method of corrective action and accept the plan in writing before work can proceed.
  - 2. All work on the well must be in accordance with all applicable local, state and federal regulations.

## 1.17 STANDBY TIME

- A. The Engineer may order the Contractor to stop his operations so that extra work not included in the Contract Documents such as testing and additional data collection can be performed. The Engineer will advise the Contractor when he proposes to do this and will schedule the request, so it causes a minimum of delay. All extra work must be accepted by the City, in writing, in advance.

## PART 2 PRODUCTS

### 2.01 DUCTILE IRON PIPE AND FITTINGS

- A. Ductile iron pipe and fittings shall be replaced in kind as shown in the Figures, pipe and fittings shall conform to AWWA C115 and C110; ANSI/AWWA C606, Rigid Groove; ANSI/AWWA C151/A21.51, Class 53
- B. Ductile iron pipe and fittings shall be as manufactured by U.S. Pipe and Foundry Company, Inc.; American Cast Iron Pipe Company; Clow Water System Company, or equal.
- C. Replace existing nuts, bolts, and gaskets with new 316L stainless steel, galvanic protection, nuts, bolts and gaskets. Gaskets for 250 psi working pressure flanges shall be 1/8" thick SBR material, hardness 80 (shore A), rated to 200 degrees F, conforming to ANSI B16.21, AWWA C207, and ASTM D1330, grades 1 and 2.
  - 1. Gaskets shall be manufactured by American Toruseal Gasket, or U.S. Pipe Flange-Tyte.

### 2.02 ISOLATION VALVE LEAK REPAIR

- A. Inflate valve seat by the following method: Drill a port in the side of the body of the existing leaking butterfly valves, install epoxy behind the seat to inflate the rubber seat and stop leak. This shall be performed for all leaking butterfly valves.
- B. Isolation valve leak repair shall be performed by D.J. Tanner, or equal.

### 2.03 AIR RELEASE VALVE

- A. Air release valves shall be replaced as shown in the Figures. Air release valves shall be manufactured and tested in accordance with American Water Works Association (AWWA) Standard C512. Valves shall be capable of withholding pressures of up to 300 psi. Two-year warranty shall be provided for all valves.
- B. Air Release Valves shall be APCO model ARV- 200 as manufactured by DeZURIK Inc. or equal.

### 2.04 AIR/VACUUM RELEASE VALVE

- A. Air/Vacuum Release Valves shall be replaced in kind as show in the Figures. Valves shall be manufactured and tested in accordance with American Water Works Association (AWWA) Standard C512.
- B. Air/Vacuum Release Valves shall be manufactured by Bermad or equal.

2.05 ALL – THREAD RODS AND NUTS ON THE 24-INCH PRATT BALL VALVE

- A. Replace all-thread rods and nuts on the Pratt ball valves as shown in the Figures. Contractor to assure proper assembly of all-thread rods and nuts during installation, with torque wrench and torque pattern validation as specified by the Manufacturer (Henry Pratt Company, a subsidiary of Mueller Company).
- B. The all-thread rods and nuts shall be carbon steel for all Pratt ball valves. The required rods and nuts for a 24-inch Ball Valve are as follows:
  - 1. 1-1/2--6 X 18-15/16 FIN STUD 16 units per valve
  - 2. 1-1/2--6 X 7-7/16 FIN STUD 8 units per valve
  - 3. 1-1/2--6 X 2-1/4 HEX NUT 40 units per valve

PART 3 EXECUTION

3.01 PRECONSTRUCTION CONFERENCE

- A. After the Award of Contract and prior to the issuance of the "Notice to Proceed," a preconstruction conference will be held with the Contractor, the City, various utility companies and Regulatory Agencies and others who are interested in the Project, for the purpose of coordinating the work. The time and place of the meeting will be set by the Engineer.
- B. In some cases, the preconstruction conference may be held after the start work date stated in the written "Notice to Proceed." This may be due to difficulty with coordination of all parties concerned, or other similar reasons.
- C. Such delays in holding the preconstruction meeting will not relieve the Contractor of any responsibilities hereunder and will not be an acceptable reason for him to request additional work completion time beyond that provided since he can be obtaining permits, mobilizing his equipment and forces, ordering materials, performing minor work, or other work if approved by the Engineer, during the interim period.

3.02 SUBMITTALS BY CONTRACTOR

- A. General: All measurements for depth shall be referenced to existing pad surface at the well location, for which elevation above NGVD is available (see figure provided).
- B. References: The Contractor shall submit a list of names of three or more owners of equivalent wells tested by their firm and shall include on said list the owner's name and address, the casing diameters and depths, the well capacity and the location of each well.
- C. Resumes: For key personnel involved in this project, including, but not necessarily limited to persons in key positions in the project, such as the drilling superintendent, drilling shift supervisors (or drillers), and the safety officer, a resume will be required for submittal to the Engineer for review and approval prior to assignment of personnel to the project.
- D. Equipment List: The Contractor shall submit a list of the equipment proposed to be utilized on the project which shall include manufacturer's load capacities, horsepower, year of



manufacture, and year of purchase by present owner. The equipment should include, but not be limited to:

1. Downhole television camera with side view options and pressure resistance capabilities to depths of 4,000 feet;
  2. Pressure recorders and pressurization equipment capable of pressurizing the well casings to pressures of 300 psi at land surface;
  3. 20-foot wire brush with bristles end to end casing scrubbers for 24-inch diameter wells;
  4. A geophysical logging truck with a downhole logging recording system with a cable and counter with capacities to 4,000 feet;
  5. Logging tools: including logging tools for gamma ray logging, collar locators, temperature logging, and internal flow logging;
  6. Electrical remote radioactive tracer release tools;
  7. Flow strippers for the cable gland at the wellhead;
  8. Diverter head;
  9. Temporary storage tanks, frac tanks (for settling of brushing back-flow material);
  10. Boom truck or crane;
  11. Packers suitable for 24-inch diameter casing inflation;
  12. Pumps;
  13. Hoses;
  14. Mixing tanks;
  15. Generators;
  16. Air compressors;
  17. Test grade pressure gauges and pressure recorders;
  18. Salt (to control free flow); and
  19. Holding tanks and transfer tanks (for the salt solutions).
  20. 131 Iodine shall be medical grade and shall be injected between 1 mCi/ml up to 4 mCi/ml on each RTS. A certification or receipt for the Iodine 131 should be present during the RTS and the Contractor shall provide copies to the Engineer and FDEP representative onsite.
- E. Specialty Tools: A specialty tool pertains to geophysical logging or other tool constructed by the Contractor for downhole use. The Contractor shall submit to the Engineer two reproducible

copies of specialty tool designs prior to tool use. These designs should include diameter, length, material, number of nozzles, nozzle diameter, pipe diameter, pumping pressure, pumping rate (in gallons per minute), sensor location(s), sensitivity range, and date of last calibration. If calibration of a specialty tool is conducted just prior to use, a separate submittal that provides calibration information will be made following calibration of the tool.

- F. Subcontractors List: The Contractor shall submit a complete list of all proposed subcontractors to be used in the work. Where possible, the Contractor shall utilize the skills of a specialist service company, expert in the type of service for which they are employed. The name and the background of the company and the individuals providing the services shall be submitted to the Engineer for approval prior to beginning work. The Engineer reserves the right to reject any service company.
- G. Instrument Calibrations: The Contractor shall submit to the Engineer at least 72 hours before testing begins calibration data for each measuring instrument to be used in testing. The date of calibration shall be no more than 180 days old. The calibration records shall contain the following information:
  - 1. Flow meter calibration sheet: Serial Number, Model Number, Gears, Test apparatus size, Meter reading and flow rate for at least three steps, Percent error for each step, tester's name and title.
  - 2. Pressure gauge calibration sheet: Serial Number, Model Number, Scale range, Meter reading and inches of mercury for at least three steps covering the entire range of the gauge, Percent error for each step, Tester's name and title.
- H. Video Television Survey: The Contractor shall submit to the City three field copies of the video television survey for the well on the day the well is surveyed, via USB flash drive after the completion of the survey.
- I. Geophysical Logs and Radioactive Tracer Survey: The Contractor shall submit to the Engineer two copies of each of geophysical log of the well on the same day the logs are run, and 10 report copies of the logs on completion of well testing and provide electronic copies of logs in ASCII format.
- J. Daily Log: The Contractor shall prepare and submit to the Engineer one reproducible copy of the daily log of site activities on the morning, the following workday for which the daily log was prepared. The daily log shall include the date, well name, weather conditions, tasks undertaken, the times of task beginnings and endings, a log of pay items completed, calculations, recorded test data, and work-related notes. The daily log shall be available for inspection at the site at all times.
- K. Waste Disposal Plan: The Contractor shall prepare and submit to the Engineer two copies of a plan to dispose of the fluids and wastes generated in the process of doing the Work. The waste disposal plan should include the methods for fluid collection, containment, and disposal, the settling out, separating, and disposal of waste materials, and should comply with all applicable federal, state, and local regulations for collection, transport, and disposal of waste products.
- L. Health and Safety Plan: Two copies of the Contractor's Mechanical Integrity Testing Health and Safety Plan will be submitted to the Engineer and will include but not be limited to a description of the Health and Safety procedures relevant to Mechanical Integrity Test

procedures and Material Safety Data Sheets for all chemicals and hazardous materials that will be used in the performance of the Work.

- M. Accident Reports: One copy of the Contractor's accident report form should be submitted to the Engineer within 24 hours of the occurrence of any accident in connection with the work.
- N. Records Required by Law: The Contractor shall maintain all records required by governmental agencies having jurisdiction and shall submit such records to them as may be required. Two copies of all such material shall be furnished to the Owner.

### 3.03 SEQUENCE OF WORK

- A. Due to the time-critical nature of the work of this Project, the activities required shall be performed in strict conformance with the sequence and schedule times specified below. Do not deviate from this sequence and schedule without written authorization from the Engineer.
- B. Prior to mobilizing at the project site, the Contractor is required to have all employees and subcontractors that will work at the site complete a mandatory operations meeting. The meeting agenda will be prepared and provided by City staff. Coordinate with the Consultant upon award of Contract. The meeting will highlight the requirements placed on the Contractor to always coordinate all field activities that may impact any operational activities of the WWTP and/or well field facilities.
- C. Contractor to locate all exiting utilities including air lines for the surge system, capillary tubing for pressure transmitters, signal wiring and power conduits (460V) around concrete pads to avoid damaging such utilities. Contractor to provide pre-construction video documentation of existing equipment and instrumentation conditions at each well to documents existing conditions prior to commencing construction. Video must include close ups of transmitters and face plates as well as the existing road and concrete pad conditions prior to starting construction and or MIT activities.
- D. To avoid disruption to existing operations, provide coordination with other related projects, and/or minimize impacts on adjacent property owners, the Work will be constructed in the following sequence:
  1. Contractor shall verify with the City that the aboveground control valves at the injection wellhead and the subsurface control valves upstream of the force main segments are operational and can be closed. Contractor shall coordinate with the George T. Lohmeyer Wastewater Treatment Plant Operator for the closing of all necessary valves on the 30-inch diameter injection well and force main piping.
  2. Contractor shall perform the MIT and well brushing Work. During the MIT only one well can be taken out of service at a time.
  3. Contractor shall restore site and remove all excavated material and debris from the grasses and the work area and leave these surfaces equivalent or better than their original condition.
- E. A Mechanical Integrity Test (MIT) and well brushing shall be performed on each Injection Well. Prior to the MIT, each casing will be cleaned using a brush as stated in the MIT Plan provided in Appendix A. The MIT and brushing work will follow the sequence below:

1. Specific Injectivity Test (by City).
2. Pumping of clear water into injection well in preparation for well video.
3. Pre-brushing video survey.
4. Use weighted fluid to balance artesian conditions in well so it does not flow at surface (kill well).
5. Disassemble of wellhead and install flow diverter and piping to well pad backwash drainage.
6. Clean the casing with a brushing tool.
7. Air lift and back flow water from injection well to dispose of particulate material removed from wells casing. Flow or pump to clear. Discharge shall go to backwash discharge system. Settled particulate shall be properly disposed offsite.
8. Contractor to collect samples from the brushing tool.
9. Kill well.
10. Run in packer and assemble temporary well header.
11. Pressure Test.
12. Disassemble temporary well header, remove packer, and reassemble wellhead as required and restore to service.
13. Post-brushing specific injectivity test by City.
14. Post-brushing well video.
15. Temperature and Gamma Logs.
16. Radioactive Tracer Test.
17. Rig down and begin hardware replacement (Nuts/bolts/gaskets, concrete collar), and painting of above ground piping.
18. Painting of wellhead, fittings, piping, and appurtenances.

Well Number	Event or Activity	Event or Activity	Event or Activity	PHASE 1 AND 2 TO BE COMPLETED BY:
IW-1	Phase 1: Brushing	Phase 2: Mechanical Integrity Testing	Phase 3: Hardware replacement (as shown in the drawings), concrete collar mortar repair, painting.	12/30/2023
IW-2	Phase 1: Brushing	Phase 2: Mechanical Integrity Testing	Phase 3: Hardware replacement (as shown in the drawings), concrete collar mortar repair, painting.	12/30/2023
IW-3	Phase 1: Brushing	Phase 2: Mechanical Integrity Testing	Phase 3: Hardware replacement (as shown in the drawings), concrete collar mortar repair, painting.	12/30/2023
IW-4	Phase 1: Brushing	Phase 2: Mechanical Integrity Testing	Phase 3: Hardware replacement (as shown in the drawings), concrete collar mortar repair, painting.	12/30/2023
IW-5	Phase 1: Brushing	Phase 2: Mechanical Integrity Testing	Phase 3: Hardware replacement (as shown in the drawings), concrete collar mortar repair, painting.	12/30/2023

### 3.04 SITE CLEANUP

- A. The Contractor shall at all times during the execution of this Contract keep the work site free and clear of all rubbish and debris. As soon as the work is completed on each half, the accumulated rubbish or surplus materials shall be promptly removed. The Contractor shall also restore in an acceptable manner all property, both public and private, which has been displaced or damaged during the prosecution of the work and shall leave the site and vicinity unobstructed and in a neat and presentable condition.
- B. In the event of delay exceeding two days after written notice is given to the Contractor by the Engineer to remove such rubbish or materials or to restore displaced or damaged property, the Engineer may employ such labor and equipment as he may deem necessary for the purpose, and the cost of such work, together with the cost of supervision, shall be charged to the Contractor and shall be deducted from any monies due him. The Project shall not be considered as having been completed until all rubbish and surplus materials have been removed and disposed of properly.

END OF SECTION

SECTION 012000  
MEASUREMENT AND PAYMENT

PART 1 GENERAL

1.01 GENERAL

- A. Payment for all work completed under this Contract shall be made in accordance with the provisions of Article 7 of the Contract and Conditions on the basis of the specific provisions of this section of the Specifications.
- B. The Contractor shall receive and accept the compensation as provided in the Contract's Proposal, as full payment for furnishing all labor, materials, tools and equipment, for performing all operations necessary to complete the work under this Contract, and also in full payment for all loss or damages arising from the nature of the Work, or from the action of the elements or from unforeseen difficulties which may be encountered during the prosecution of the work until the final acceptance by the City.
- C. The cost breakdown (or schedule of values) referred to herein is defined in the Proposal pages and in this section of the Specifications. The cost breakdown (schedule of values) approved by the Engineer will be used as the basis for making progress payments and for determining the cost of extra work which is the same or similar (as determined by the Engineer) to that defined in the schedule of values.
- D. The prices stated in the Proposal include full compensation for overhead and profit, all costs and expenses for taxes, labor, equipment, furnishing and repairing small tools and ordinary equipment, mobilization, home office expenses and general supervision, materials, commissions, transportation charges and expenses, patent fees and royalties, bond, insurance, labor for handling materials during inspection, together with any and all other costs and expenses for performing and completing the work as shown on the Contract Drawings and specified herein. In addition, the Contractor shall include the actual cost of social security taxes, unemployment insurance, worker's compensation, fringe benefits, inclusive of life and health insurance, union dues, pension, pension plans, vacations, and insurance and contractor's public liability and property damage insurance involved in the work based on the actual wages paid to such labor and all other general costs and profits, prorated to each Item.
- E. Unless otherwise specifically stated elsewhere herein, the Contractor shall include in the prices bid all materials, electrical supply, fuel, lubricants, temporary equipment, temporary wiring, temporary piping and fittings, pumps, gages, and all other items of whatever nature required to completely test, balance, and put into fully operational condition all equipment and/or systems supplied by either the City or the Contractor and installed as a part of this Project. Further, any test materials supplied by the Contractor shall be completely satisfactory to the City. Any decision as to whether a particular material is suitable for test purposes shall be at the sole discretion of the Engineer whose decision shall be final. Any material considered not suitable shall be immediately replaced by the Contractor with suitable material and no extra compensation will be allowed.
- F. It is the intent of the City to obtain a complete and working installation under this Contract, and any items of labor, equipment or materials which may reasonable be assumed as necessary to accomplish this end shall be supplied whether or not they are specifically shown on the Figures or stated herein.

## 1.02 PROPOSAL ITEMS

- A. Item No. 1: for furnishing all materials, labor and equipment and suppressing the well differential back pressure in each of the Floridan Aquifer injection wells, as appropriate, as required for all phases of the mechanical integrity testing, complete, will be paid for at the aggregate sum price bid per each well completed. The price bid shall be full compensation for furnishing all materials, labor and equipment, necessary, and shall include, but not be limited to furnishing salt or other approved product; providing water-proof storage of the salt or other product; providing mixing and holding tanks, hoses, valves, pipe, fittings, pumps and other similar items; mixing the brine solution with effluent or potable water and pumping it into the well; suppressing the backpressure for all phases of the mechanical integrity testing as required; mixing and adding in additional brine solution if necessary; safeguarding against spillage of the brine solution and accidental restoration of well differential backpressure; cleaning up any spillage; disposing of the brine solution after completion of the mechanical integrity testing; complying with security restrictions; coordination with the Engineer; transportation and handling costs; replacing or restoring damaged fences, paving, utilities, structures, grass, concrete pad, trees, and similar items, to equal or better than original condition, and all other appurtenant and miscellaneous items and work necessary.
- B. Item No. 2: for furnishing all materials, labor and equipment and cleaning the interior casing of each of the Floridan Aquifer injection wells, as appropriate, for its entire length, complete, will be paid for at the aggregate sum price bid per each well satisfactorily cleaned. The price bid shall be full compensation for furnishing all materials, labor and equipment necessary, and shall include, but not be limited to, removing the well head and properly storing for re-installation; furnishing and installing new neoprene gaskets and flange joint materials; cleaning the well for the entire length of the casing; safeguarding against spillage of brine solution and accidental restoration of well differential backpressure; cleaning up any spillage; re-cleaning the well if necessary after the television survey if initial cleaning insufficient; all cost for re-televising the casing after the second cleaning; exercising care not to, lose any materials or equipment in the well; retrieval of any accidentally lost items in the well; complying with security restrictions; coordination with the Engineer; transportation and handling costs; replacing or restoring damaged utilities, structures, fences, paving, grass, trees and similar items to equal or better than original condition; and all other appurtenant and miscellaneous items and work necessary. The term "clean" to as used herein shall mean the complete removal of any slime buildup and other foreign material on the inside of the casing to the satisfaction of the Engineer whose decision shall be final.
- C. Item No. 3: for furnishing all materials, labor and equipment and pressure test the interior of the injection well, for its entire length, including packer integrity test, moving the packer device for 2 times if required, and pressurizing the casing two times if required, will be paid for at the aggregate sum price bid per each well satisfactorily tested. The price bid shall be full compensation for furnishing all materials, labor and equipment necessary, and shall include, but not be limited to, placing equipment into position; installing packer into well and integrity testing it, using certified gauge and recorder; furnishing certified test reports (for both pre-work certification and postwork certification); replacing packer if it fails the test, and testing it (this shall be repeated as necessary until a packer is furnished that is acceptable and passes test); lowering packer near bottom of well casing as specified, and pressure testing the casing using certified gauge and recorder (if test is satisfactory, removing the packer from the well and re-installing the wellhead and connecting piping, including furnishing and installing all new gaskets. If the test is unsuccessful, reposition the packer higher and repeat the test. If the second test is unsuccessful, the City may order additional tests under Contingent Item No. 4 of the

Proposal. If later radioactive tracer tests reveal that the well is sound, it will be presumed that the Contractor's packer was faulty, and all previous tests, shall be repeated at the Contractor's expense. Previous tests ordered under Item 4 shall also be at the Contractor's expense and will not be paid for); exercising extreme caution when pressurizing the packer and the casing to avoid damage to the well; if damage occurs to the well due to the Contractor's negligence, they shall be responsible for repairing the well at their expense to the satisfaction of the Engineer (this could possibly create a situation where the Contractor would have to furnish a new well to equal or better the existing one, and at their expense); exercising extreme caution not to lose the packer tools and other items into the well; if the packer, tools or other items are lost into the well, it (they) shall be retrieved by the Contractor; safeguarding against spillage of the brine solution and accidental restoration of well differential backpressure; cleaning up any spillage; furnishing the testing log and other data; obtaining and paying for any required permits for the entire project under this, and all other Items, unless otherwise stated to be furnished by the City; replacing or restoring any damaged utilities, structures, fences, paving, grass, trees, and similar items to equal or better than original condition; and all other appurtenant and miscellaneous items and work necessary.

- D. Contingent Item No. 4: for furnishing all materials, labor and equipment to reposition the packer device and re-pressurize the interior well casing, in addition to that covered in Item 3, if ordered by the Engineer, will be paid for at the unit price bid for each repositioning and retesting ordered. The price bid shall be full compensation for furnishing all labor, materials and equipment necessary, and shall include, all applicable provisions specified under Item 3. If it is confirmed by television survey or radioactive tracer testing that the packer is defective, the City will not be responsible for this payment Item. See Item 3.
- E. Item No. 5: for furnishing all materials, labor and equipment and performing a temperature log and radioactive tracer survey at the injection well, will be paid for at the aggregate sum price bid per each well satisfactorily surveyed. The price bid shall be full compensation for furnishing all labor, equipment and materials necessary, and shall include, but not be limited to, placing equipment and tools into position, lowering the tools into the well; taking the temperature log; taking background log; furnishing radioactive material as required; exercising proper storage and handling procedures for the radioactive material at all times for complete safety; performing the dynamic tests; furnishing the survey logs and other data required; safeguarding against spillage of the brine solution, if still in the well, and accidental restoration of well differential backpressure; cleaning up any spillage; exercising care not to lose any materials or equipment into the well; retrieval of any accidentally lost items in the well; replacing or restoring damaged utilities, structures, fences, paving, grass, trees and similar items to equal or better than original condition; complying with security restrictions; coordination with the Engineer; transportation and handling costs; and all other appurtenant and miscellaneous items and work necessary. If cracks, defects or other anomalies are encountered during the survey, the Engineer may order additional time (survey) under Contingent Item No. 6 of the Proposal.
- F. Contingent Item No. 6: for furnishing all materials, labor and equipment and performing additional radioactive survey or temperature log in addition to that covered in Item 5, if ordered by the City, will be paid for at the unit price bid for each hour ordered. The price bid shall be full compensation for furnishing all labor, materials and equipment necessary, and shall include, all applicable provisions of Item No. 5. This item will only be used by the City to continue radioactive survey or temperature logging work while the Contractor's equipment is still in the well and/or in place at the well.



- G. Item No. 7: for furnishing all materials, labor and equipment and performing a closed circuit television survey of the Floridan Aquifer injection well, as appropriate, including the interior casing for its full length and the open borehole to its full depth, will be paid for at the aggregate sum price bid per each well satisfactorily surveyed. The price bid shall be full compensation for furnishing all materials, labor and equipment necessary, and shall include, but not be limited to, placing television camera/lights into the well; furnishing an air conditioned viewing truck or van where the television monitor can be viewed by the Engineer simultaneously with the survey; recording the survey on videotape; surveying the well casing and borehole; furnishing DVD's or portable USB flash drives and logs required; safe guarding against spillage of the brine solution, if still in the well, and accidental restoration of well differential backpressure; cleaning up any spillage; exercising care not to lose any materials or equipment into the well; retrieval of any accidentally lost items in the well; complying with security restrictions; coordination with the Engineer; transportation and handling costs; replacing or restoring any damaged utilities, structures, fences, paving, grass, trees and similar items to equal or better than original condition; and all other appurtenant and miscellaneous items and work necessary. This Item will not be used to pay for re-televising necessary due to improper cleaning as described under Item 2 and such re- televising shall be included in the prices bid for Item 2.
- H. Contingent Item No. 8: for waiting time and standby time, not included in the other items, when ordered and approved by the City Manager or designee, will be paid for at the unit price bid, times the number of hours authorized by the City Manager or designee.
- I. Item No.9: for work under this section which shall include but not be limited to all materials, labor, tools, ladders, scaffolding, required for painting all pipes, fittings, valves, surge tanks, and other appurtenances for five deep injections wells, including all specified preparatory work required for painting surfaces as required by specification requirements.
- J. Item No. 10: for furnishing all labor, material, and equipment to repair the exterior concrete of the existing precast concrete cylinder pipe as necessary per the Figures, and to replace ductile iron pipe, fittings, couplings, nuts, bolts, gaskets, valves, air-vacuum valves, Pratt ball valve studs/nuts as necessary per the Figures, and other improvements not covered in other bid items.
- K. Item No.11: payment for mobilization and demobilization at the GTL WWTP well field located within the City of Fort Lauderdale at 1000 SE 21 Street, Fort Lauderdale, Florida. Mobilization includes providing/installing/removing project sign, required field coordination and project management, submittals, RFI's, insurance, site cleanup, sanitary facilities, bonds, video, labor associated with permit acquisition, staging area, testing, construction trailer and demobilization.
- Note: This total must not exceed ten percent of the items 1-11 above. Take the sum of the items 1 through 11 and multiply it by 0.10 to calculate this total.
- L. Contingent Item No. 12: for the repair of existing 30-inch isolation butterfly valves in the event that the pipe flow cannot be stopped adequately to perform the Work.
- M. Item No. 13: payment for permit fees will be based upon the actual permit fees required from the various agencies having jurisdiction for construction of the project, in accordance with the Contract Documents. The allowance amount shown on the bid schedule is an estimate of permit fees required for the project and is a cost pass through item and no mark-ups will be added to this item. The Contractor shall produce documentation upon request verifying actual cost. Only

permit fees substantiated by the Contractor and approved by the City of Fort Lauderdale will be paid as part of this item.

- N. Item No. 14: This account is for all labor, materials, equipment and services necessary for modification or extra work required to complete the Project because of unforeseeable conditions, unforeseeable conflicts between existing elements of work and the proposed work; for minor changes required to resolve any unforeseeable conditions, Revised Regulations, Technological and Products Development, Operational Changes, Schedule Requirements, Program Interface, Emergencies and Other Miscellaneous Costs; and for adjustments to estimated quantities shown on the unit prices of the proposal to conform to actual quantities installed; and associated time related to this work only if ordered by the Engineer.

Payment to the Contractor under the Allowance Account Items will only be made for work ordered in writing by the City Manager or his designee. Any portion of these accounts remaining after all authorized payments have been made will be withheld from Contract payments and will remain with the City.

Note: Since Bid Item Nos. 4, 6, 8 and 12 are Contingent Items, and because of the nature of the Allowance Permit Fee Reimbursement Bid Item 13 and the Allowance Unforeseen Conditions Bid Item 14, they may or may not be used in their entirety at the option of the City. Any overrun or underrun provisions contained within the Contract Documents shall not be applicable to these items. If one account has been depleted and funds are available in the other accounts, the City may under a Change Order approval authorize use some of the available funds to complete the Project.

#### 1.03 COST BREAKDOWN/SCHEDULE OF VALUES

- A. The Contractor shall submit a detailed Cost Breakdown of the Proposal Form costs for the work. The Cost Breakdown shall be submitted along with the Baseline Construction Progress Schedule within forty (40) calendar days after Notice to Proceed. The Cost Breakdown shall be in accordance with General Conditions.
- B. The Contractor's Cost Breakdown (Schedule of Values) shall be broken down in accordance with the construction progress schedule, by major structures/portion of work, by Division of work (e.g. Technical Division or trade), by major pieces of equipment, Specification Sections, or other relevant criteria for this particular Project. The Contractor shall separate cost of labor and materials and installation (of equipment, as applicable) in sufficient detail to serve as a basis for computing values for progress payments during construction.
- C. For the various portions of the work:
  - 1. Each item shall include a directly proportional amount of the Contractor's overhead and profit.
  - 2. For items on which progress payment will be requested for stored materials, break down the value into:
    - a. The cost of the materials (delivered and unloaded, with taxes paid). Paid invoices are required for stored materials.
    - b. The total installed value.

3. The sum of all values listed in the cost breakdown shall equal the Subtotal Contract Sum and Grand Total Base Bid.
- D. Upon request of the Engineer, the Contractor shall support the values in the Cost Breakdown which will substantiate their corrections. The accepted Cost Breakdown or Schedule of Values shall be used only as the basis for the Contractor's periodic and final applications for payment.
- 1.04 PAYMENT
- A. General: Progress payments will be made monthly as specified in the Agreement.
  - B. It is the intent of the City to obtain in the Bidder's Proposal, at the time of bid, a complete price for all work shown or reasonably inferred from the Contract Documents.
- 1.05 NONPAYMENT FOR REJECTED OR UNUSED PRODUCTS
- A. Payment will not be made for following:
    1. Loading, hauling, and disposing of rejected material.
    2. Quantities of material wasted or disposed of in a manner not called for under the Contract Documents.
    3. Rejected loads of material, including material rejected after it has been placed by reason of failure of Contractor to conform to provisions of Contract Documents.
    4. Material not unloaded from transporting vehicle.
    5. Defective Work not accepted by the City.
    6. Material remaining on hand after completion of Work.
- 1.06 PARTIAL PAYMENT FOR STORED MATERIALS AND EQUIPMENT
- A. Partial Payment: Partial payments will be made in accordance with the General Conditions.
  - B. Final Payment: Will be made only for materials incorporated in work; remaining materials, for which partial payments have been made, shall revert to Contractor unless otherwise agreed, and partial payments made for those items will be deducted from final payment.
- 1.07 FINAL APPLICATION FOR PAYMENT
- A. Final payment shall be subject to the conditions and requirements included in the General Conditions and all others included in the Contract.

PART 2 PRODUCTS (NOT USED)

PART 3 EXECUTION (NOT USED)

END OF SECTION

SECTION 099100  
PAINTING

PART 1 GENERAL

1.01 GENERAL

- A. The work under this section shall include all material, labor, tools, ladders, scaffolding, etc., required to complete the painting for aboveground steel surge tanks and aboveground pipe, fittings, and valves. All material shall be brought on the job in the original unopened containers bearing the manufacturer's label and shall be mixed or thinned and applied strictly in accordance with the manufacturer's directions. Any material brought to the job in opened containers shall be rejected. The Contractor shall store materials in a location or locations where directed by the Engineer and such storage space shall be kept clean and neat and every precaution taken to prevent all danger of fire. Oily rags and papers shall not be left in the buildings overnight unless placed in covered metal cans.
- B. Aluminum surfaces and all small items of equipment with factory finish in good condition shall not be painted. Name and data plates on equipment shall not be painted over, under any circumstance.
- C. All work shall be carefully protected while painting is going on, using suitable cover cloths where necessary. Any work defaced or damaged by the painters shall be made good by the Contractor as directed by the Engineer. The Contractor shall be responsible for cleaning all accidentally spilled materials such as paint, varnish, grout and concrete from the structures and equipment, and shall leave the work in complete and perfect condition in every detail.
- D. The Contractor shall assure that the surfaces are in proper condition to receive paint and shall guarantee paint against peeling and discoloration, due to faulty application or workmanship, in accordance with the terms of the Performance and Payment Bond.
- E. Wherever a "Specialty paint" or other painter's material is mentioned herein by Trade name or by manufacturer's name for a specific location, material, surface, or service condition, it is mentioned as a standard of comparison only and it is not intended that products by other manufacturers for like purposes may not be used if approved by the Engineer. Where any surface is acid etched, it shall be water-flushed and left until perfectly dry before paint is applied.
- F. The Contractor shall submit in quintuplicate to the Engineer for approval, a schedule of proposed paints to use for the various locations and purposes, at least 60 days before the anticipated data of use. This schedule shall indicate the type of paint, the manufacturer's name and the manufacturer's stock number and trade name of the product. No paint material shall be purchased until approval of such list has been made by the Engineer. The Contractor shall also submit in quintuplicate the manufacturer's recommended methods of application of the various types and kinds of paints and enamels.
- G. Finish colors and tints shall be as selected by the Engineer to conform to the color scheme of the Site. The Contractor shall tint each coat differently to assist the Engineer in checking work progress and to help in the elimination of "Holidays."

## PART 2 PRODUCTS

2.01 See Coating Schedule in Attachment A.

## PART 3 EXECUTION

### 3.01 GENERAL

- A. All painting shall be done in first-class workmanlike manner. Surface preparation and special coating shall be performed only by crews experience in this work and approved by the Engineer. No painting shall be performed upon damp or frosty surfaces, or in wet, foggy or freezing weather. No material painted inside shall be carried outside in wet or freezing weather until it is thoroughly dry. Any painting found defective shall be removed and repainted.
- B. All surfaces shall be thoroughly brushed and cleaned before being painted and shall be perfectly clean and dry where paint is applied. All paint shall be applied only via brush or roller, no spray painting is allowed. In the case of iron, steel, and metal work generally, all abrasions in the priming coat shall be carefully wire brushed and sandpapered smooth, removing all scales, ridges, or paint skin, and the surfaces shall then be painted the required number of coats herein specified.
- C. Where material or equipment is shop primed, all bad spots shall be cleaned and touched up with the recommended primer before the finish coats are applied.
- D. Before iron or steel is painted, all voids, open or hollow places and irregularities shall be filled with a mixture suitable for the material and purpose. Paints shall be evenly spread and well brushed out so that there shall be no drips, runs or sagging of materials.
- E. Drop cloths and masking where appropriate shall be used where necessary to prevent paint or other material from defacing the structures or equipment in place, and upon completion of the work, all paint spots shall be removed from all surfaces and all faceplates and nameplates verified to be unpainted.

### 3.02 PREPARATION

- A. All surfaces to be painted shall be prepared in accordance with best practice with particular attention to the following:
  - 1. Ferrous Metals: Remove all rust and loose scale with wire brush and wipe clean. Wash metal surfaces with mineral spirits to remove grease, oil and dirt.
  - 2. Galvanized Work: All galvanized surfaces shall be treated with a metal passivator prior to cold galvanizing.
  - 3. The Contractor shall furnish the Engineer a plate, purchased from the Steel Structures Painting Council, representing the No. 6 blast cleaning to be used as a field guide. Under no circumstances shall blasted surfaces be permitted to rust, or condensation to form, prior to coating. Preferably, no more than 8 hours shall elapse between cleaning and coating.

4. Testing Equipment: Furnish for use on the Project for paint inspection, wet and dry film thickness gauges. Paint manufacturers representative shall verify all required DFT.

3.03 COATING SCHEDULE

- A. See Attachment A.

END OF SECTION  
*(Attachment A follows)*

ATTACHMENT A  
COATING SCHEDULE

Area	Surface Preparation	Paint Manufacturer	
		Carboline	Amercoat
Ferrous Metal (Surge Tanks)	SSPC-6 Commercial Blast Cleaning	1st Coat: Carboline Carbozinc 859 Int Coat: Carboguard 890 Finish Coat: Carbothane 133 Min Total DFT: 10 mils	1st Coat: Amercoat 68 HS 2nd Coat: Amerlock 2/400 3rd Coat: Amercoat 450HSG Min Total DFT: 10 mils
Ductile Iron Piping System (Above Grade)	SSPC-6 Commercial Blast Cleaning	1st Coat: Carboguard 890 Int Coat: Carboguard 890 Finish Coat: Carbothane 133 HB Min Total DFT: 12.0 mils	1st Coat: Amerlock 2/400 2nd Coat: Amerlock 2/400 3rd Coat: Amercoat 450HSG Min Total DFT: 12.0 mils
Aluminum surfaces in contact with steel	Metal must be clean, dry and free from rust, oil, dust, or other foreign material.	Prime: 1 coat Finish: 2 coats Bitumastic 300M	Prime: None Finish: 2 coats No. 78.
Galvanized Metal.	Per paint manufacturer's recommendation	Prime: 1 coat primer Finish: 2 coats Glamortex Enamel	Prime: 1 coat No. 86 Finish: 2 coats No. 52

SECTION 332113.05  
MECHANICAL INTEGRITY TESTING

PART 1 GENERAL

1.01 SCOPE OF WORK

- A. The mechanical integrity testing under this Contract shall be accomplished using the methods and general sequence described under Section 011101 and herein; however, the Contractor shall submit a more detailed sequence to the City for approval before the beginning of the work. The Contractor shall use extreme caution to prevent any loss of equipment, tools or other items into the wells and shall be fully responsible for retrieving any such items immediately, at no expense to the City. All pressure tests must be conducted in the presence of the City or authorized representative.
- B. The wells to be tested are Injection Wells IW-1 through IW-5 at the G.T. Lohmeyer Wastewater Treatment Plant Deep Injection Wells site.
- C. The Injection Wells have a 24-inch outside diameter (OD), 0.500-inch wall thickness injection casing set to total depths of 2,800 to 2,820 feet below land surface (bls) and were constructed with a nominal 22-inch diameter open borehole extending from the bottom of the casing to approximately 3,305 to 4,010 feet bls.

1.02 PURPOSE

- A. The purpose of the Mechanical Integrity Testing (MIT) shall be to demonstrate that the injection well has adequate mechanical integrity (MI) in conformance with the requirements of Chapter 62-528, F.A.C. Mechanical integrity shall be established as follows:
  - 1. Confirm integrity of casing (i.e., internal mechanical integrity)
  - 2. Confirm integrity of cement seal (i.e., external mechanical integrity)
- B. The Contractor shall perform internal and external mechanical integrity tests on the casings of five deep injection wells and perform all appurtenant work in accordance with the above Contract Documents, the MIT Plan, and applicable rules and regulations.

1.03 NOTIFICATIONS

- A. The Contractor shall notify the Engineer a minimum of 7-calendar days prior to beginning the pressure test, geophysical logging, and the radioactive tracer survey activities at each injection well so that the City and regulatory agency staff can be properly notified.

1.04 EQUIPMENT REQUIREMENTS

- A. General: The Contractor will provide all equipment associated with performing Radioactive Tracer Survey (RTS) testing, including logging tools, stripper/stand pipe to control flow, certified flow meter, pumps, and hoses.
- B. Wellhead Assembly: The stripper head assembly used during the video survey, Geophysical logging, and the radioactive survey shall be bolted to the wellhead above the 6-inch gate valve.



The stripper head assembly used must be of sufficient length to house the longest of the wire line tools used for the testing between the gate valve and the pack-off mounted at the top of the assembly. The pack-off must be adjusted so that the tools can be moved freely up and down the well with minimal leakage from the well. The assembly shall include a 4-inch valve and tee, which will be used to inject potable water during the surveys. The assembly shall be fitted with a calibrated pressure gauge for use during the tests.

- C. Wellhead Hardware: The wellhead hardware shall be replaced with new 316 stainless steel nuts and bolts and new gaskets when the wellhead is reassembled after testing. The Contractor shall ensure that the new gaskets make contact and seal flanges between contact of nuts and bolts. Pipe flange should be painted before reassembly.
- D. Water Line: The Contractor shall provide a potable water supply line for use during the video surveys. This line shall be connected to the existing 4-inch valve on the Contractor's stripper head. It shall be equipped with two reduced pressure zone (RPZ) backflow prevention device in series to prevent the backflow of effluent into the water supply source. It shall also be equipped with a continuous recording digital flow meter and totalizer capable of measuring flows accurately in the range of 0 to 250 gpm.
- E. Packer: The Contractor will provide and install the packer assembly to utilize in the casing pressure test, and all related packer equipment, including but not limited to drop pipe, hoses, pressurizing equipment, and certified pressure gages for both the pressurizing equipment and the casing header. The packer shall be a Baker Single Set Production Injection Packer Model 300-01, a TAMJ Packer, or approved equal. The packer shall be a diameter appropriate for the size of well casing to be pressure tested. The packer shall seal tightly against the casing walls to effectively isolate the well casing from the open hole below the casing. It will be inflated to a maximum of 400 psi or at a pressure such that the well casing is not damaged, and an effective hydraulic seal is obtained or otherwise approved by the Engineer. The Engineer will be the sole judge as to the effectiveness of the packer element isolation of the well casing.
- F. Pressure Gauges and Recorders: The pressure gauges and recorders used for the casing pressure tests shall be properly marked and identified and shall be properly stored and handled at all times to avoid damage. Five copies of the certified recalibrations shall also be furnished to the Engineer. Pressure gauges used for the casing pressure tests shall have been calibrated within the past 60 days and the Contractor shall submit a certification of the pressure gauge calibration prior to the performance of the first pressure test. Calibrations shall be done by the Contractor as required during the work of this project. The calibration shall still be accurate by the last date the gauge is used.

#### 1.05 MATERIAL REQUIREMENTS

- A. The Contractor shall kill the well using a dense food-grade salt solution. No barite or mud-based additives shall be used in the well.

#### PART 2 PRODUCTS (NOT USED)

## PART 3 EXECUTION

### 3.01 GUIDELINES

- A. The Contractor shall set up all equipment required to prepare for suppressing the density differential pressure, video surveys, cleaning, performing the pressure test and the radioactive tracer surveys. Only one well can be taken out of service at a time.
- B. The Contractor will notify the City when ready for a Specific Injectivity Test. The City will perform a pre-brushing Specific Injectivity Test on each well prior to any MIT activities on the well.
- C. A pre-brushing and post-brushing video survey shall be performed to document the conditions of the casing and borehole prior to and after brushing. The contractor shall pump sufficient clear water into the injection well prior to all video surveys.
- D. The Contractor shall inject sufficient salt solution into the well to balance the differential pressure and disassemble the wellhead as necessary for the casing interior cleaning and pressure testing. The brine solution shall remain in the well during the cleaning and pressure testing steps, after which time it shall be transferred to another well if clean enough for reuse or shall otherwise be disposed of by the Contractor. Under no circumstances shall brine solution be spilled or disposed of on the ground surface.
- E. The Contractor shall clean each casing interior using a minimum 20-foot long casing brush. Six round-trip passes with first 1/3 turning of the brush. Six round-trip passes with second 1/3 turning of the brush. Six round-trip passes with third 1/3 turning of the brush. Round trip passes shall be performed from the top of the casing to the casing bottom and back to the surface. Additional passes may be performed as necessary at locations where excessive scaling were observed during pre-brushing video survey.
- F. Pressure testing will be conducted to determine internal mechanical integrity. The final casing strings will be pressured to 200 psi and monitored using certified pressure gages and recording pressure transducers for a minimum of one hour for any change in pressure of plus or minus five percent.
- G. The Contractor will notify the City when ready for the post-brushing Specific Injectivity Test. The City will perform a post-brushing Specific Injectivity Test followed by the post brushing video survey.
- H. An RTS and temperature log will be performed to determine external mechanical integrity. The RTS tool will be configured with one gamma ray detector above and two detectors below the tracer ejector port. A casing collar locator (CCL) shall be positioned below the tool to precisely locate the bottom of the casing.
- I. The Contractor shall notify the Engineer at least seventy-two hours prior to the initiation of all testing activities unless otherwise indicated. The Engineer will contact FDEP to coordinate testing schedule. The schedule of testing will be dependent upon the availability of FDEP staff to observe testing activities. All pressure tests must be conducted in the presence of the City or authorized representative.

- J. All testing procedures and results shall meet the requirements of Chapter 62-528 F.A.C and the approved MIT plan.

### 3.02 CASING INTERIOR BRUSHING

- A. The Contractor shall clean the casing with a brushing tool prior to proceeding with the standard MIT test procedures. The entire length of casing shall be cleaned. If the later Video survey indicates insufficient cleaning, the well shall be re-cleaned by the Contractor, at their expense, to the satisfaction of the Engineer. If the Video survey must be repeated because of insufficient cleaning, in the opinion of the Engineer, it shall also be at the Contractor's expense
- B. The casing brushing tool shall be a sufficient diameter to contact the interior casing wall. The tool shall be a minimum of 20-feet long and have steel bristles end to end. A typical casing brush configuration is provided in Figure No. 12.
- C. The tool must have the ability to be rotated 360 degrees and lowered at a maximum rate of ten feet per minute. Round trip passes shall be performed from the top of the casing to the casing bottom and back to surface. Additional passes may be performed as necessary at locations where excessive scaling were observed during pre-brushing video survey.
- D. The Contractor shall provide and install a flow diverter and piping to well pad backwash discharge system.
- E. The Contractor shall submit drawings of the proposed tool to the Engineer for review prior to utilization.
- F. After brushing, the contractor shall airlift and backflow water from injection well to dispose of particulate material removed from well casing. Flow or pump to clear discharge to backwash discharge system at each injection well pad.
- G. The City shall conduct a post-brushing Specific Injectivity test. The Contractor shall include time for this in the costs for the brushing. It is not considered standby time.

### 3.03 VIDEO TELEVISION SURVEY

- A. General: Pre-cleaning and post-cleaning video surveys shall be performed by the Contractor to assess the condition of each well's interior prior to and after well cleaning. Video surveys shall be conducted by a qualified service company using equipment capable of surveying and recording the required depth and visual. The Contractor may use their own equipment providing it is capable of surveying as required and the Contractor shall furnish proof of the capability of the equipment. The Video camera shall be centralized within the borehole and have side view (sufficient to view 90 degrees from down hole view) and color capability.
- B. The Contractor shall insure that the well and borehole fluid is of sufficient clarity as determined by the Engineer to allow a video survey to be conducted. The Contractor shall provide and install temporary piping, pumps, etc. capable of adequately stressing the borehole. The Contractor shall pump into or out of the well a quantity of clear water not less than three volumes of the entire well and borehole. If after pumping three volumes of potable water into the well, the water quality does not permit a clear picture of the inside of the well, the Contractor may be required to perform additional pumping services to assure a good survey as specified above.

- C. While performing operations related to the Video survey, the well may be under artesian pressure and may flow. The Contractor shall provide and use a stripper head assembly and any other equipment necessary to keep any flow under control at all times.
- D. During the video survey, the Contractor shall stop the camera's progress as instructed by the Engineer at depths where there may be potential flaws in the casing or other features to allow for thorough examination at those locations.
- E. Costs for pumping clear water into or out of the borehole to achieve the desired level of clarity for the Video surveys and tapes (including time spent waiting for the Video equipment) and for rig and crew labor for all activities associated with preparing, performing and dismantling equipment related to the Video survey shall be included with the Contractor's testing costs for the injection well.
- F. The Contractor shall repeat the Video survey at their own cost if water quality is inadequate or the borehole is not properly conditioned, as evaluated by the Engineer.

#### 3.04 PACKER ASSEMBLY

- A. The packer assembly shall be pressure tested at the surface prior to insertion into the casing.
- B. The well shall be killed with salt.
- C. The packer shall be installed in the well using drill pipe or tubing to a depth within twenty feet of the base of the casing to be tested.
- D. The packer will be inflated to a pressure not exceeding 400 psi or at a pressure such that the well casing is not damaged, and an effective hydraulic seal is obtained.

#### 3.05 PRESSURE TEST SET-UP

- A. Furnish and install wellheader sufficient to seal the drill pipe and wellhead prior to running the pressure test.
- B. Furnish a pressure gauge calibrated in one psi increments for the pressure test. The gauge supplied shall have a calibrated rating from 0.0 to 300 psi with an accuracy of plus or minus 0.75 psi. Furnish certification that the pressure gauge has been calibrated within sixty days prior to testing. The pressure gauge shall be acceptable to the Engineering Consultant prior to its use.
- C. Pressures in the well will be observed and recorded with certified, calibrated pressure gages and recording pressure transducers. If the pressure change exceeds five percent (plus or minus), the location of the leak shall be determined. If the leak occurs from the packer, then the packer will be reset (using the same procedure as above) until the pressure test can be successfully completed.

#### 3.06 PRESSURE TEST

- A. Install and inflate packer within twenty feet from the base of the injection casing.
- B. Install wellhead assembly and pressure gauges on well.
- C. Fill casing with potable water, pressure casing, and bleed off any air remaining in the casing.

- D. Run preliminary test, which shall be observed by the Engineer at their option. Notify the Engineer of the anticipated start time of the final packer test 7-calendar days prior to the initiation of all tests. Engineer will coordinate testing schedule with the FDEP.
- E. With FDEP and Engineer on-site to witness, run final pressure test at a minimum of 200 psi for a one-hour duration and monitor wellhead pressure within the casing. If less than a five percent (plus or minus) change occurs over the one-hour testing period, the well has successfully demonstrated internal mechanical integrity. The packer will then be deflated and removed from the well.
- F. If the test fails, the Contractor shall move the packer upwards for approximately 10 feet and re-start the pressure test. If the test still fails, additional repositioning of the packer within 100-feet of the bottom of casing and repeating the test shall be as ordered by the City. If the test still fails, and subsequent Radioactive surveys indicate no casing failure, it will be presumed that the Contractor's packer did not create a positive seal, and the Contractor shall be required to repeat the pressure test at his expense. No payments will be made to the Contractor if it is subsequently determined that the test failure was caused by the seating of the packer. If the packer fails during packer operation verification, it will be concluded that the packer was faulty during any previous test that did not demonstrate casing integrity. The Contractor shall repeat this test at his expense. A faulty packer shall be replaced with one that will meet the test. The Engineer is aware that packers have limited inflation cycles and will attempt to minimize the verification of packer operation. However, any integrity failure for which the packer operation cannot be eliminated must be repeated at the Contractor's cost. It is anticipated that each new packer will be tested at the wellhead to verify its capacity to seat and deflate.
- G. Pressures in the well will be observed and recorded with certified, calibrated pressure gages and recording pressure transducers. If the pressure change exceeds five percent (plus or minus), the location of the leak shall be determined. If the leak occurs from the packer, then the packer will be reset (using the same procedure as above) until the pressure test can be successfully completed.
- H. Accurately measure the volume of bleed-off water as casing pressure is released after test. Measured water released from the casing must NOT be discharged to the ground.

### 3.07 TEMPERATURE LOG

- A. The well will be left undisturbed for a minimum of 12 hours prior to running a differential and gradient temperature log from land surface to the bottom of the injection zone.
- B. Calibrate geophysical tools within one week of testing.

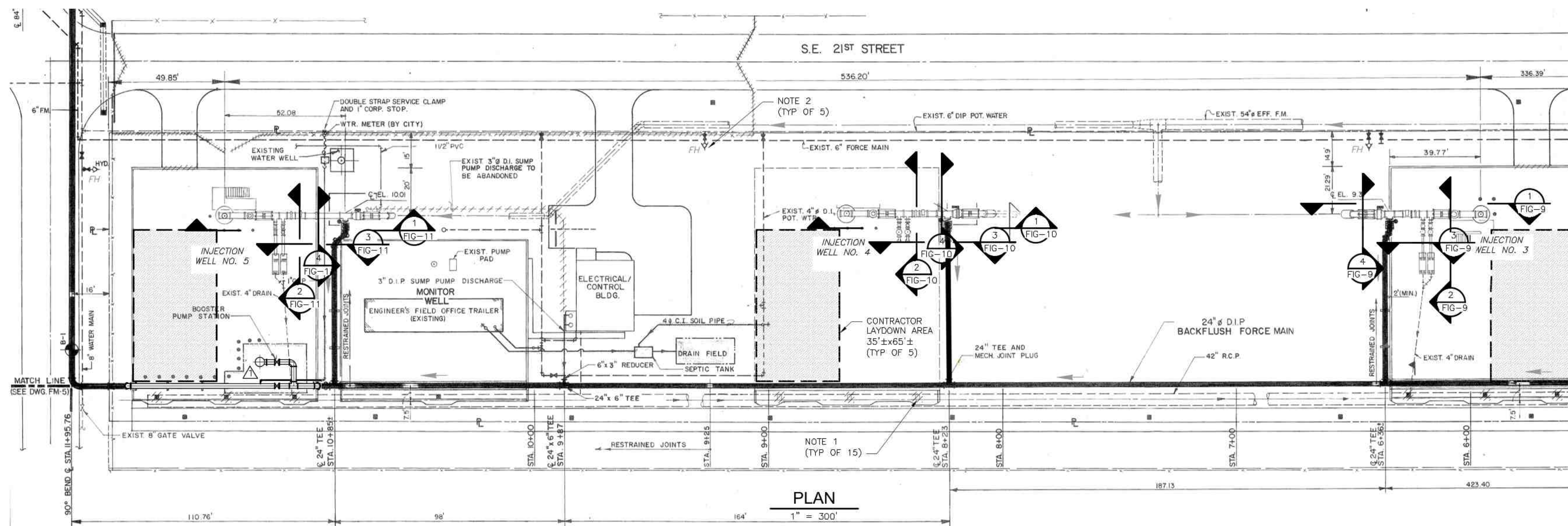
### 3.08 RADIOACTIVE TRACER SURVEY (RTS)

- A. General Requirements:
  - 1. Prior to conducting the RTS, and radiation officer will perform a background Geiger counter survey of site.
  - 2. Calibrate geophysical tools within one week of testing.

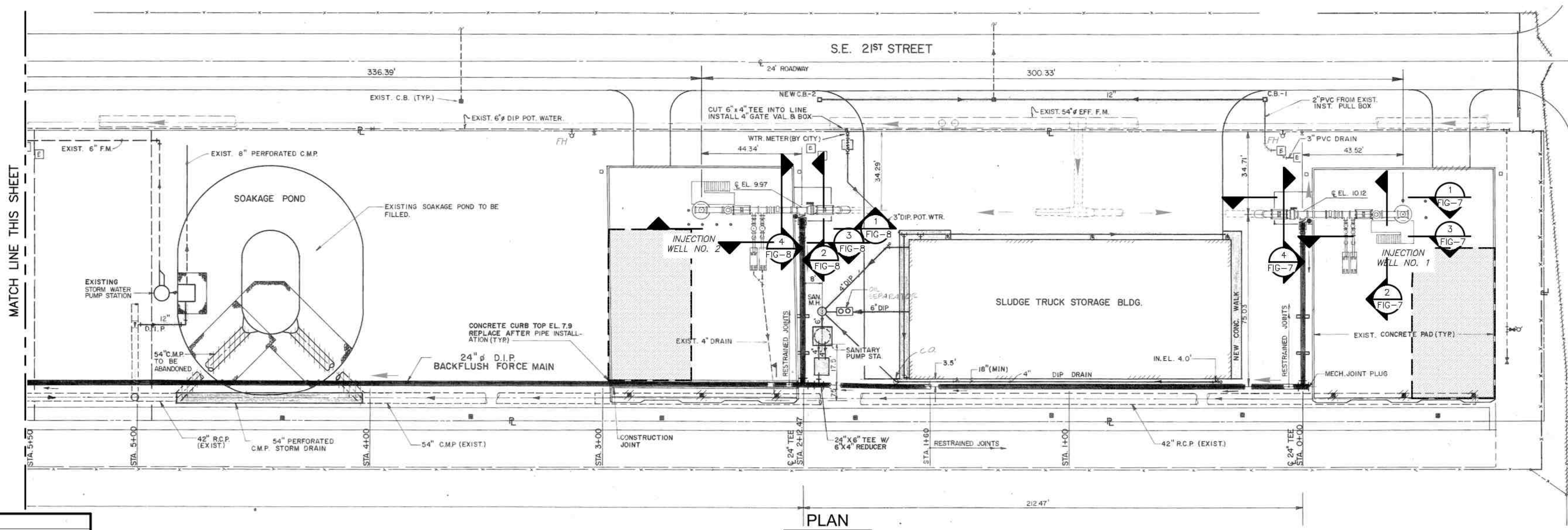
3. The tracer (Medical Grade Iodine 131) must be obtained within 72 hrs. of the initiation of the RTS. A certification or receipt for the Iodine 131 shall be present during the RTS and the Contractor shall provide copies to the Engineer and FDEP representative onsite.
  4. All flow and pressure gauges must be calibrated within 60 days of use.
  5. Gamma detectors shall be field calibrated by the geophysical logging crew, using a standard, after the tool has been loaded with tracer and prior to insertion into the well, if requested by the Engineer. Documentation of the radioactive tracer injection time must be provided, and the tracer injection time must be calibrated to +/- 1 millisecond. No time lag between injection and monitoring is permitted.
  6. A static RTS and additional dynamic tests may be conducted if requested by the FDEP.
- B. Provide required notification to Engineer prior to initiating RTS. The Engineer shall witness the RTS. Engineer will coordinate testing schedule with FDEP and will provide them with the option to witness the test.
- C. A background gamma ray log with the casing collar locator (CCL) shall be run from the top of the injection casing to the bottom of the injection zone. The bottom of the injection casing should be accurately located with the CCL by repeat passes. The background gamma ray log should be printed on all RTS logs run up or down the injection well during testing.
- D. Dynamic Tests 1 and 2:
1. The tool shall be positioned with the ejector five feet above the bottom of the injection casing and a low-flow (no to exceed 5 ft/min with a minimum of 3 ft/min) rate of injection is established in the well. The water for this low flow rate shall be from the nearby potable line and a calibrated flowmeter shall be installed in a convenient location.
  2. A radioactive tracer slug shall be released (1 to 3 millicuries), and the detectors will be kept stationary and gamma ray detectors monitored in time-drive mode for 60 minutes.
  3. The tool will then be raised to 200 feet above the bottom of the injection casing to record the dispersion of the radioactive tracer. If upward movement of the tracer is detected during the monitoring period, the operator shall immediately log out of position to a new position approximately 20 feet above the highest point tracer is detected and resume time drive monitoring. If the logging tool is to be moved upwards in the event of possible detection of tracer by the upper detector, the tool should not be moved prior to the time period required for the tracer to travel from the middle detector to the lower detector (theoretically 2 minutes for a 5 foot/minute flow rate).
  4. Flushing between the radioactive tracer survey tests and logging after the flushing is only mandatory if there is an adverse casing stain. If staining is detected on the casing, the well will then be flushed with a minimum volume of approximately 65,000 gallons, and the gamma ray log of the interval logged in the previous step is run again. It is assumed here that open hole water can be pulled for this procedure conducted during the MIT.
  5. Run an additional second low-flow dynamic test for 30 minutes, in the same manner repeating the steps described above.

6. The well will be flushed as described above and the contractor will lower the tool to the top of the injection zone (or a minimum of 100 feet below the base of the casing into a cavernous zone) and release the remaining Iodine 131.
7. Conduct a final gamma ray logging pass (the same interval as logged in the background gamma ray log).
8. Additional RTS testing shall be performed should logging results suggest additional testing is necessary. The need for additional tests will be determined in the field and will be based on logging response and field discussions with an FDEP representative witnessing the RTS.

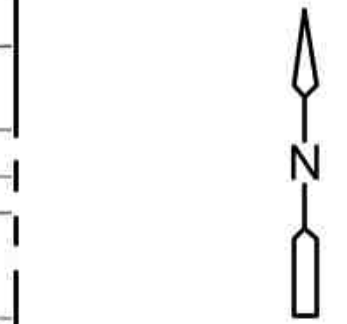
END OF SECTION



PLAN  
1" = 300'



PLAN  
1" = 300'



- NOTES: 1. SILT PROTECTION REQUIRED AROUND ALL EXISTING CATCH BASINS DURING CONSTRUCTION.
2. CONTRACTOR TO INSTALL TWO IN SERIES BACKFLOW PREVENTERS TO EXISTING FIRE HYDRANT TO ENABLE THE CITY CONNECTION OF WATER METER FOR MONITORING OF WATER USAGE.
3. PAINT ABOVE GROUND PIPE, FITTINGS, VALVES, AND SURGE TANK. SEE PAINT SPECIFICATION SECTION FOR SURFACE PREPARATION AND APPLICATION.

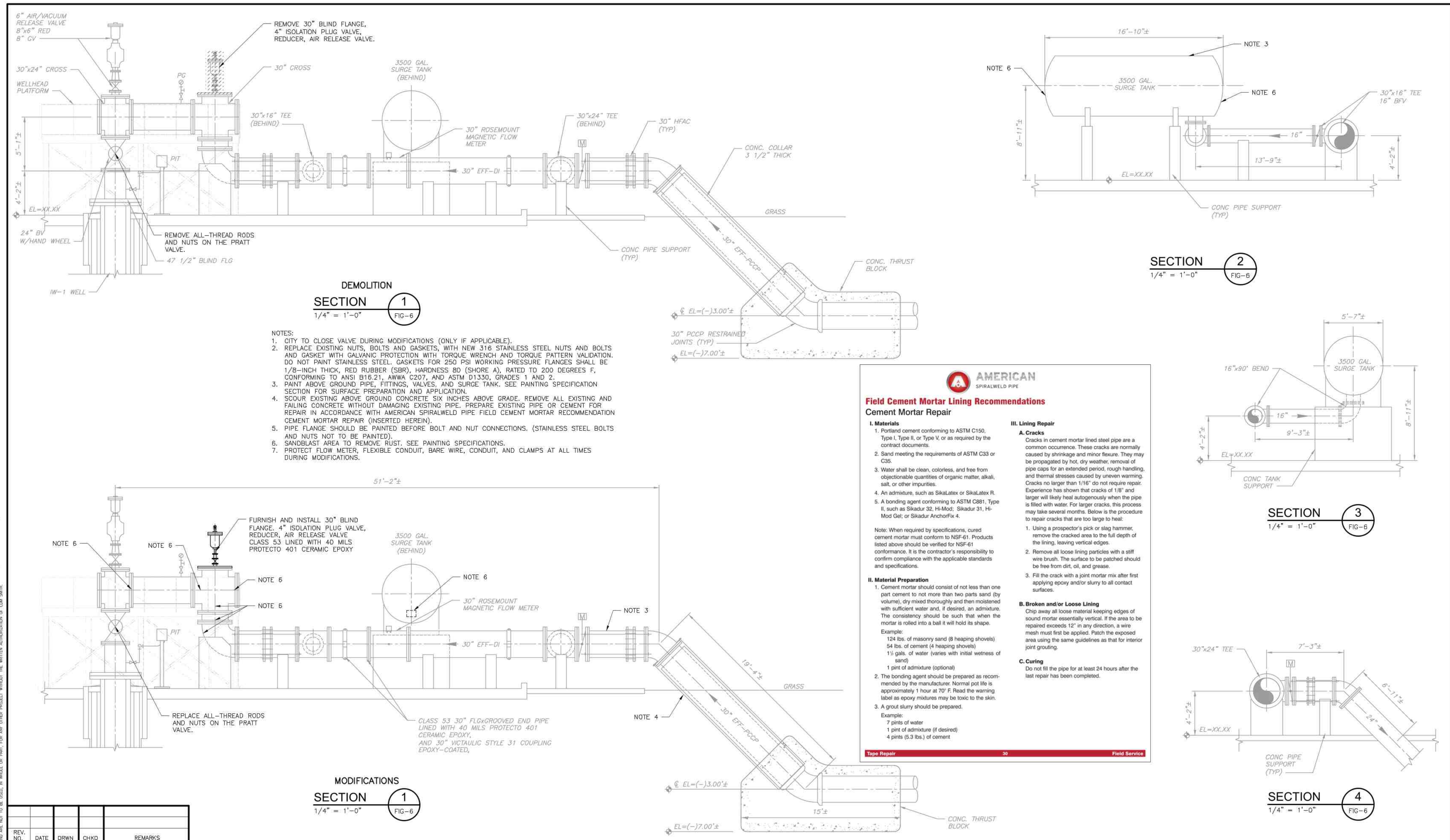
REV. NO.	DATE	DRWN	CHKD	REMARKS



Figure No. 6  
G.T. Lohmeyer Injection Facility  
Wells Site Plan

p:\pw.cdm-smith.com\PL\1\Documents\6017\233234\02 Project Information\03 Data\30 Reports\04 Figures\FIG 6.dwg  
 ALL RIGHTS RESERVED. NO PARTS OF THIS DOCUMENT ARE TO BE REPRODUCED OR TRANSMITTED IN ANY FORM OR BY ANY MEANS, ELECTRONIC OR MECHANICAL, INCLUDING PHOTOCOPYING, RECORDING, OR BY ANY INFORMATION STORAGE AND RETRIEVAL SYSTEM, WITHOUT THE WRITTEN PERMISSION OF CDM SMITH.





- NOTES:**
- CITY TO CLOSE VALVE DURING MODIFICATIONS (ONLY IF APPLICABLE).
  - REPLACE EXISTING NUTS, BOLTS AND GASKETS, WITH NEW 316 STAINLESS STEEL NUTS AND BOLTS AND GASKET WITH GALVANIC PROTECTION WITH TORQUE WRENCH AND TORQUE PATTERN VALIDATION. DO NOT PAINT STAINLESS STEEL. GASKETS FOR 250 PSI WORKING PRESSURE FLANGES SHALL BE 1/8-INCH THICK, RED RUBBER (SBR), HARDNESS 80 (SHORE A), RATED TO 200 DEGREES F, CONFORMING TO ANSI B16.21, AWWA C207, AND ASTM D1330, GRADES 1 AND 2.
  - PAINT ABOVE GROUND PIPE, FITTINGS, VALVES, AND SURGE TANK. SEE PAINTING SPECIFICATION SECTION FOR SURFACE PREPARATION AND APPLICATION.
  - SCOUR EXISTING ABOVE GROUND CONCRETE SIX INCHES ABOVE GRADE. REMOVE ALL EXISTING AND FAILING CONCRETE WITHOUT DAMAGING EXISTING PIPE. PREPARE EXISTING PIPE OR CEMENT FOR REPAIR IN ACCORDANCE WITH AMERICAN SPIRALWELD PIPE FIELD CEMENT MORTAR RECOMMENDATION CEMENT MORTAR REPAIR (INSERTED HEREIN).
  - PIPE FLANGE SHOULD BE PAINTED BEFORE BOLT AND NUT CONNECTIONS. (STAINLESS STEEL BOLTS AND NUTS NOT TO BE PAINTED).
  - SANDBLAST AREA TO REMOVE RUST. SEE PAINTING SPECIFICATIONS.
  - PROTECT FLOW METER, FLEXIBLE CONDUIT, BARE WIRE, CONDUIT, AND CLAMPS AT ALL TIMES DURING MODIFICATIONS.

**AMERICAN SPIRALWELD PIPE**

**Field Cement Mortar Lining Recommendations**

**Cement Mortar Repair**

**I. Materials**

- Portland cement conforming to ASTM C150, Type I, Type II, or Type V, or as required by the contract documents.
- Sand meeting the requirements of ASTM C33 or C35.
- Water shall be clean, colorless, and free from objectionable quantities of organic matter, alkali, salt, or other impurities.
- An admixture, such as Sikalater or Sikalater R.
- A bonding agent conforming to ASTM C881, Type II, such as Sikadur 32, Hi-Mod; Sikadur 31, Hi-Mod Gel; or Sikadur AnchorFix 4.

**Note:** When required by specifications, cured cement mortar must conform to NSF-61. Products listed above should be verified for NSF-61 conformance. It is the contractor's responsibility to confirm compliance with the applicable standards and specifications.

**II. Material Preparation**

- Cement mortar should consist of not less than one part cement to not more than two parts sand (by volume), dry mixed thoroughly and then moistened with sufficient water and, if desired, an admixture. The consistency should be such that when the mortar is rolled into a ball it will hold its shape.  
Example:  
124 lbs. of masonry sand (8 heaping shovels)  
54 lbs. of cement (4 heaping shovels)  
1 1/2 gals. of water (varies with initial wetness of sand)  
1 pint of admixture (optional)
- The bonding agent should be prepared as recommended by the manufacturer. Normal pot life is approximately 1 hour at 70° F. Read the warning label as epoxy mixtures may be toxic to the skin.
- A grout slurry should be prepared.  
Example:  
7 pints of water  
1 pint of admixture (if desired)  
4 pints (5.3 lbs.) of cement

**III. Lining Repair**

**A. Cracks**  
Cracks in cement mortar lined steel pipe are a common occurrence. These cracks are normally caused by shrinkage and minor flexure. They may be propagated by hot, dry weather, removal of pipe caps for an extended period, rough handling, and thermal stresses caused by uneven warming. Cracks no larger than 1/16" do not require repair. Experience has shown that cracks of 1/8" and larger will likely heal autogenously when the pipe is filled with water. For larger cracks, this process may take several months. Below is the procedure to repair cracks that are too large to heal:

- Using a prospector's pick or slag hammer, remove the cracked area to the full depth of the lining, leaving vertical edges.
- Remove all loose lining particles with a stiff wire brush. The surface to be patched should be free from dirt, oil, and grease.
- Fill the crack with a joint mortar mix after first applying epoxy and/or slurry to all contact surfaces.

**B. Broken and/or Loose Lining**  
Chip away all loose material keeping edges of sound mortar essentially vertical. If the area to be repaired exceeds 12" in any direction, a wire mesh must first be applied. Patch the exposed area using the same guidelines as that for interior joint grouting.

**C. Curing**  
Do not fill the pipe for at least 24 hours after the last repair has been completed.

**Tape Repair** 30 **Field Service**

p:\pw.cdm-smith.com\pw\_pl\Documents\6017\233234\02 Project Information\03 Data\30 Reports\04 Figures\FIG 7.dwg  
 NOT FOR CONSTRUCTION. ALL DIMENSIONS SHOWN ARE UNLESS OTHERWISE SPECIFIED. THIS DRAWING IS THE PROPERTY OF CDM SMITH.

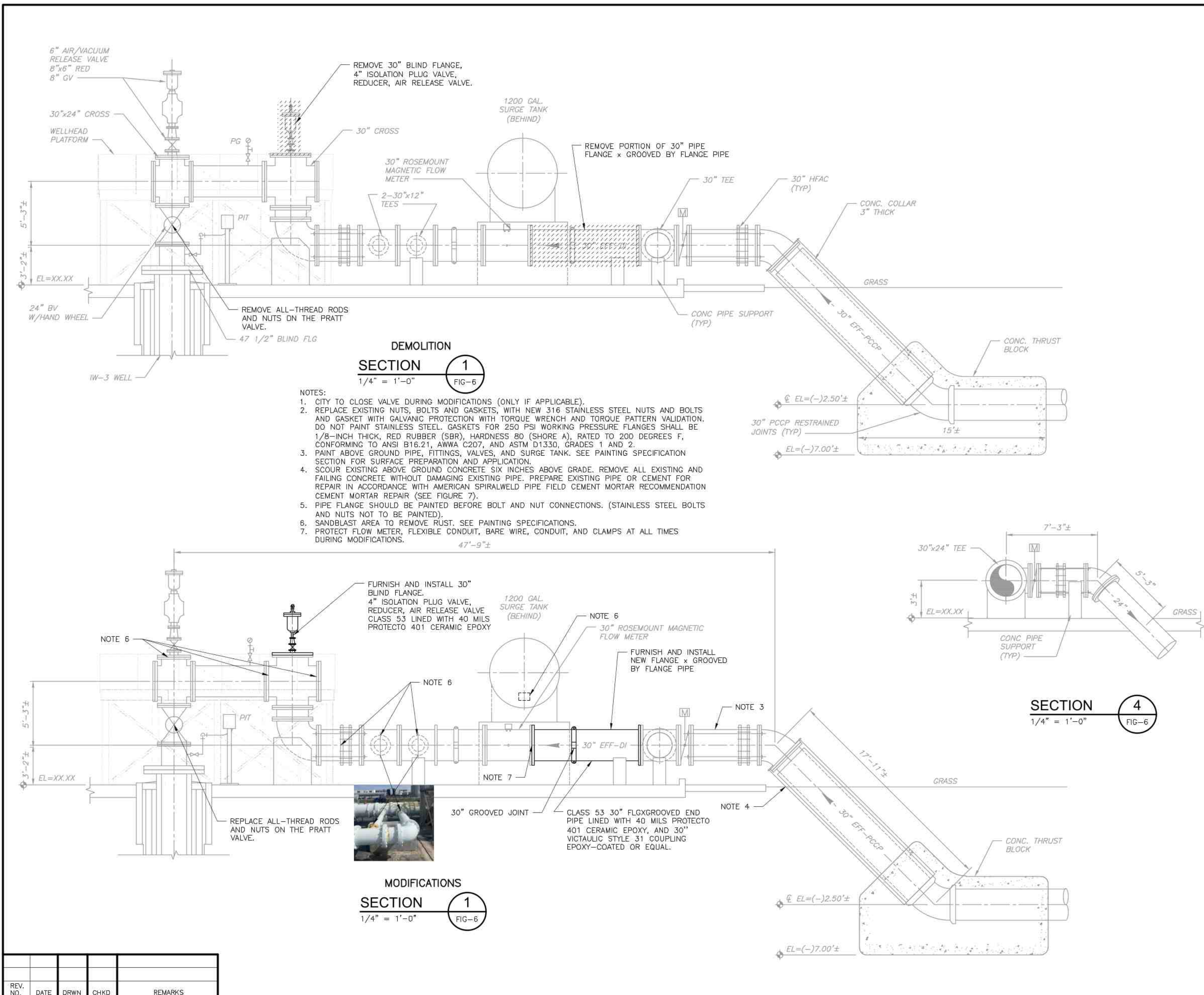
REV. NO.	DATE	DRWN	CHKD	REMARKS



Figure No. 7  
G.T. Lohmeyer Injection Facility  
IW-1 Well Head Sections



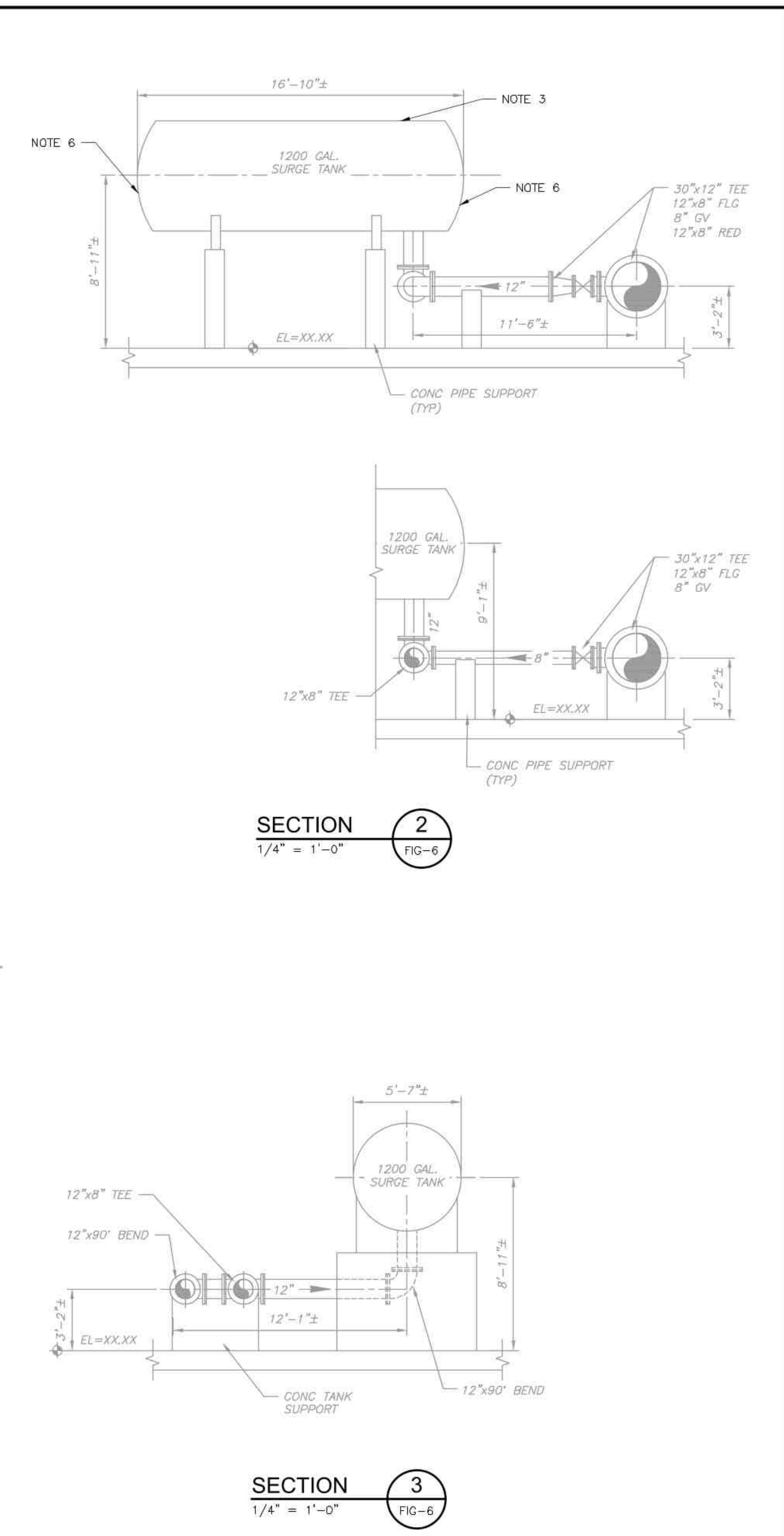
p:\pw.cdm-smith.com\pw\_pl\1\Documents\6017\_233234\02 Project Information\03 Data\_30 Reports\04 Figures\Fig 9.dwg  
 2023/05/01 10:00 AM  
 ALL RIGHTS RESERVED. NO PARTS OF THIS DOCUMENT ARE TO BE REPRODUCED OR TRANSMITTED IN ANY FORM OR BY ANY MEANS, ELECTRONIC OR MECHANICAL, INCLUDING PHOTOCOPYING, RECORDING, OR BY ANY INFORMATION STORAGE AND RETRIEVAL SYSTEM, WITHOUT THE WRITTEN PERMISSION OF CDM SMITH.



- DEMOLITION SECTION 1**  
 1/4" = 1'-0" FIG-6
- NOTES:**
- CITY TO CLOSE VALVE DURING MODIFICATIONS (ONLY IF APPLICABLE).
  - REPLACE EXISTING NUTS, BOLTS AND GASKETS, WITH NEW 316 STAINLESS STEEL NUTS AND BOLTS AND GASKET WITH GALVANIC PROTECTION WITH TORQUE WRENCH AND TORQUE PATTERN VALIDATION. DO NOT PAINT STAINLESS STEEL GASKETS FOR 250 PSI WORKING PRESSURE FLANGES SHALL BE 1/8-INCH THICK, RED RUBBER (SBR), HARDNESS 80 (SHORE A), RATED TO 200 DEGREES F, CONFORMING TO ANSI B16.21, AWWA C207, AND ASTM D1330, GRADES 1 AND 2.
  - PAINT ABOVE GROUND PIPE, FITTINGS, VALVES, AND SURGE TANK. SEE PAINTING SPECIFICATION SECTION FOR SURFACE PREPARATION AND APPLICATION.
  - SCOUR EXISTING ABOVE GROUND CONCRETE SIX INCHES ABOVE GRADE. REMOVE ALL EXISTING AND FAILING CONCRETE WITHOUT DAMAGING EXISTING PIPE. PREPARE EXISTING PIPE OR CEMENT FOR REPAIR IN ACCORDANCE WITH AMERICAN SPIRALWELD PIPE FIELD CEMENT MORTAR RECOMMENDATION CEMENT MORTAR REPAIR (SEE FIGURE 7).
  - PIPE FLANGE SHOULD BE PAINTED BEFORE BOLT AND NUT CONNECTIONS. (STAINLESS STEEL BOLTS AND NUTS NOT TO BE PAINTED).
  - SANDBLAST AREA TO REMOVE RUST. SEE PAINTING SPECIFICATIONS.
  - PROTECT FLOW METER, FLEXIBLE CONDUIT, BARE WIRE, CONDUIT, AND CLAMPS AT ALL TIMES DURING MODIFICATIONS.

**MODIFICATIONS SECTION 1**  
 1/4" = 1'-0" FIG-6

REV. NO.	DATE	DRWN	CHKD	REMARKS

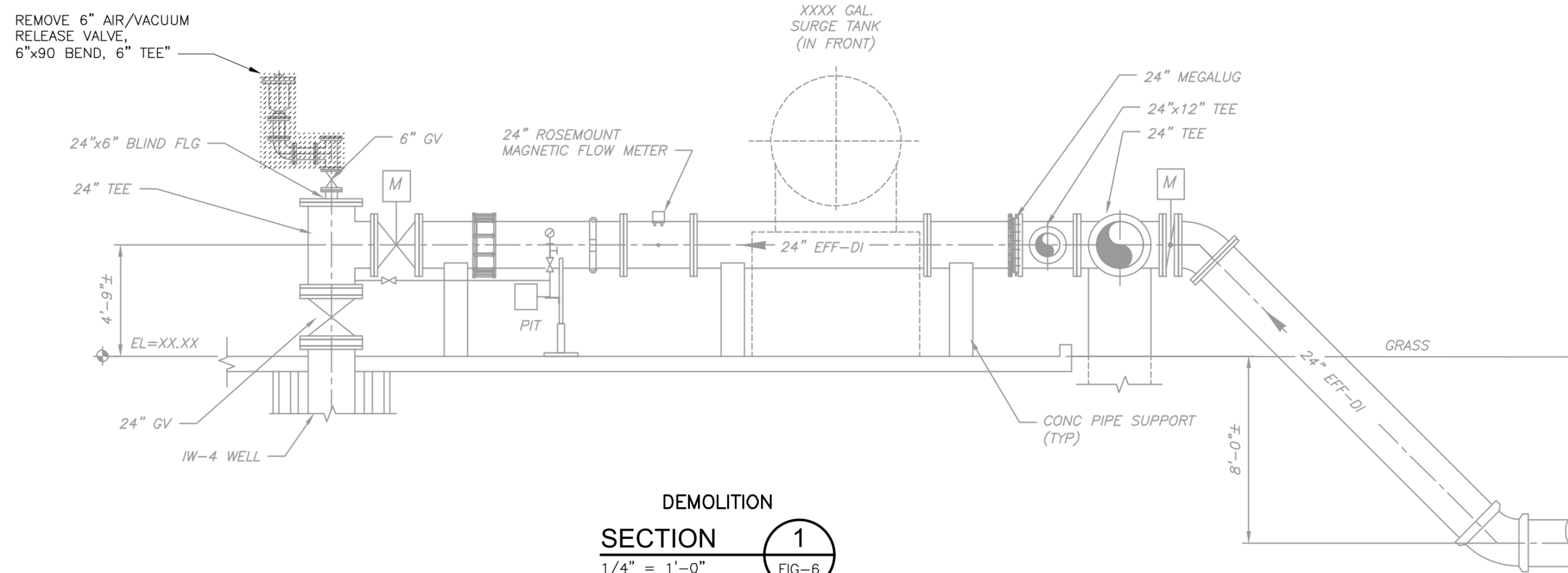


**SECTION 2**  
 1/4" = 1'-0" FIG-6

**SECTION 3**  
 1/4" = 1'-0" FIG-6

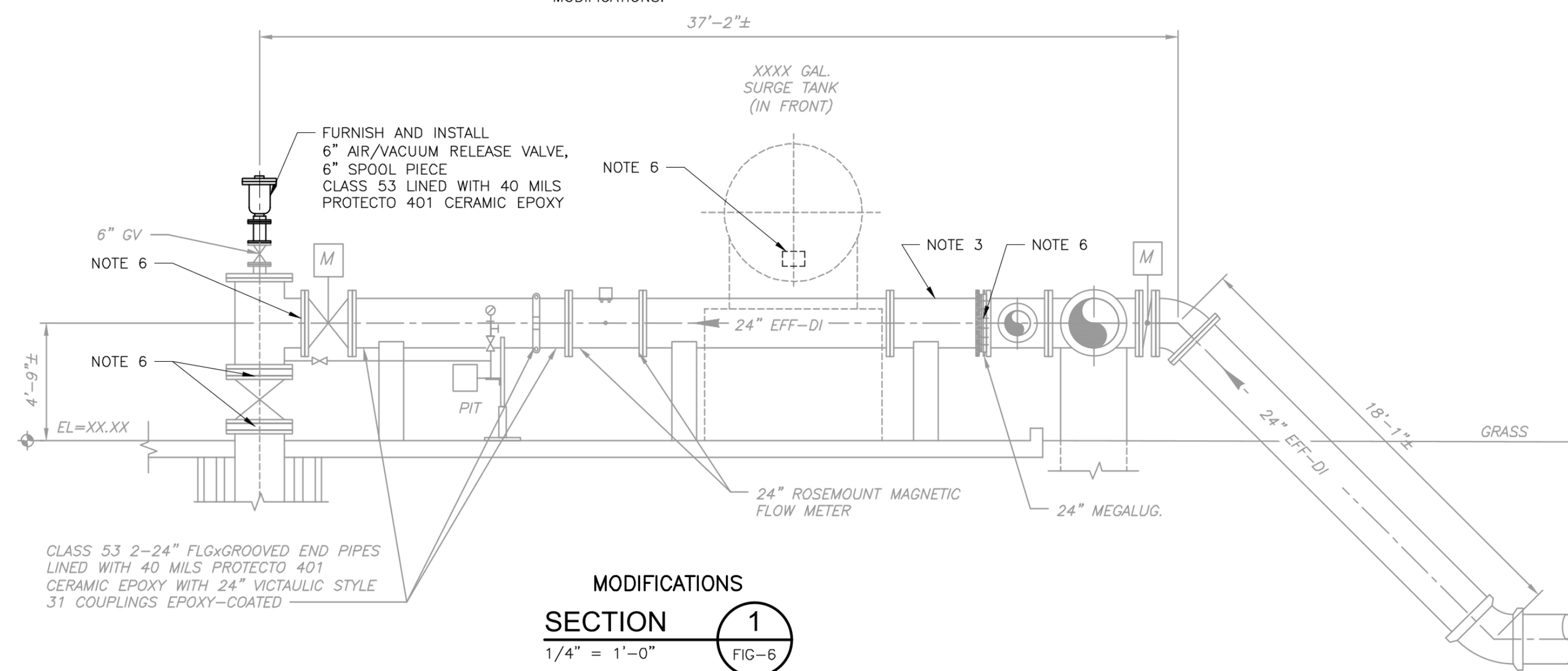


Figure No. 9  
 G.T. Lohmeyer Injection Facility  
 IW-3 Well Head Sections

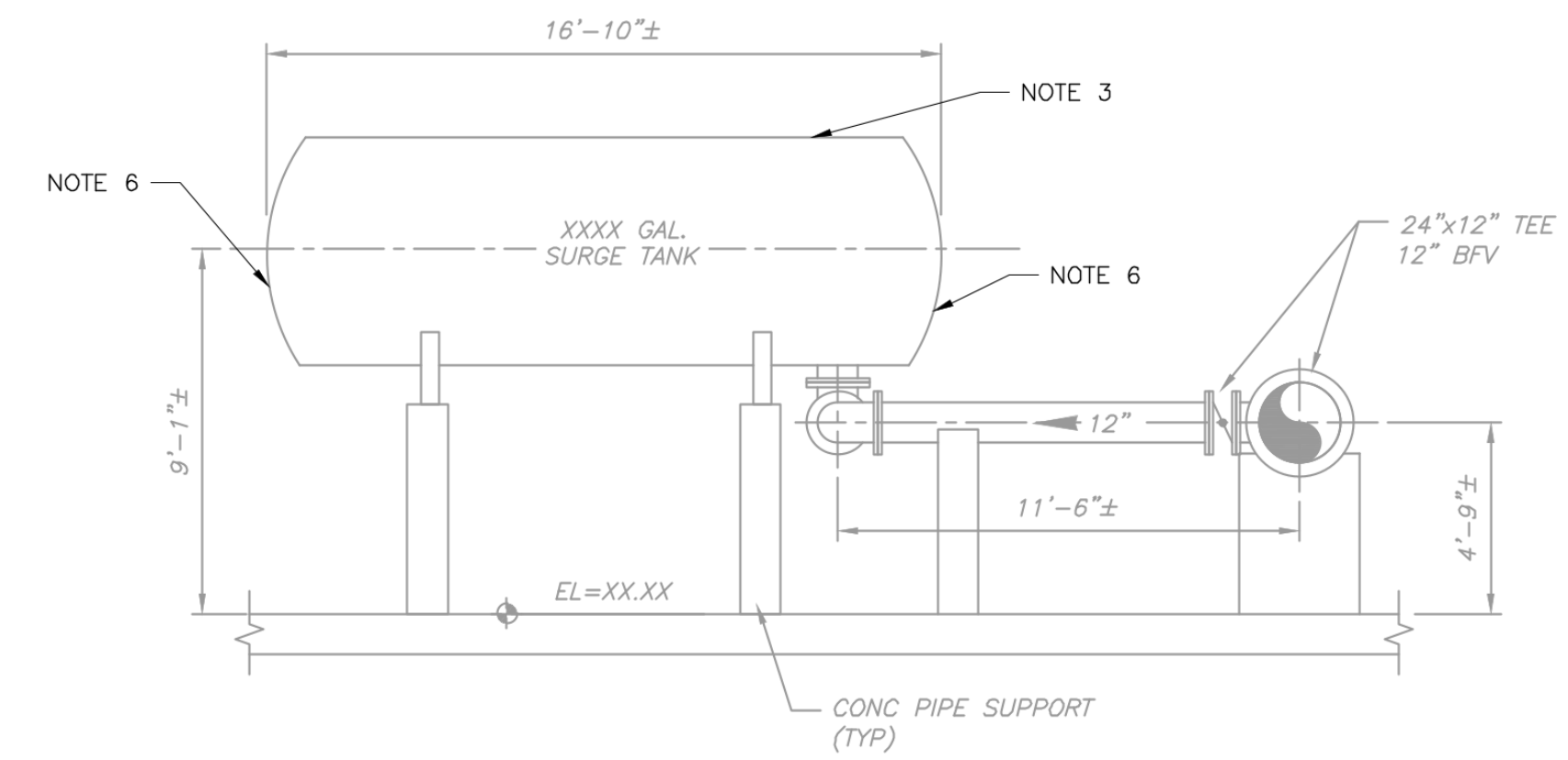


**DEMOLITION**  
**SECTION 1**  
 1/4" = 1'-0" FIG-6

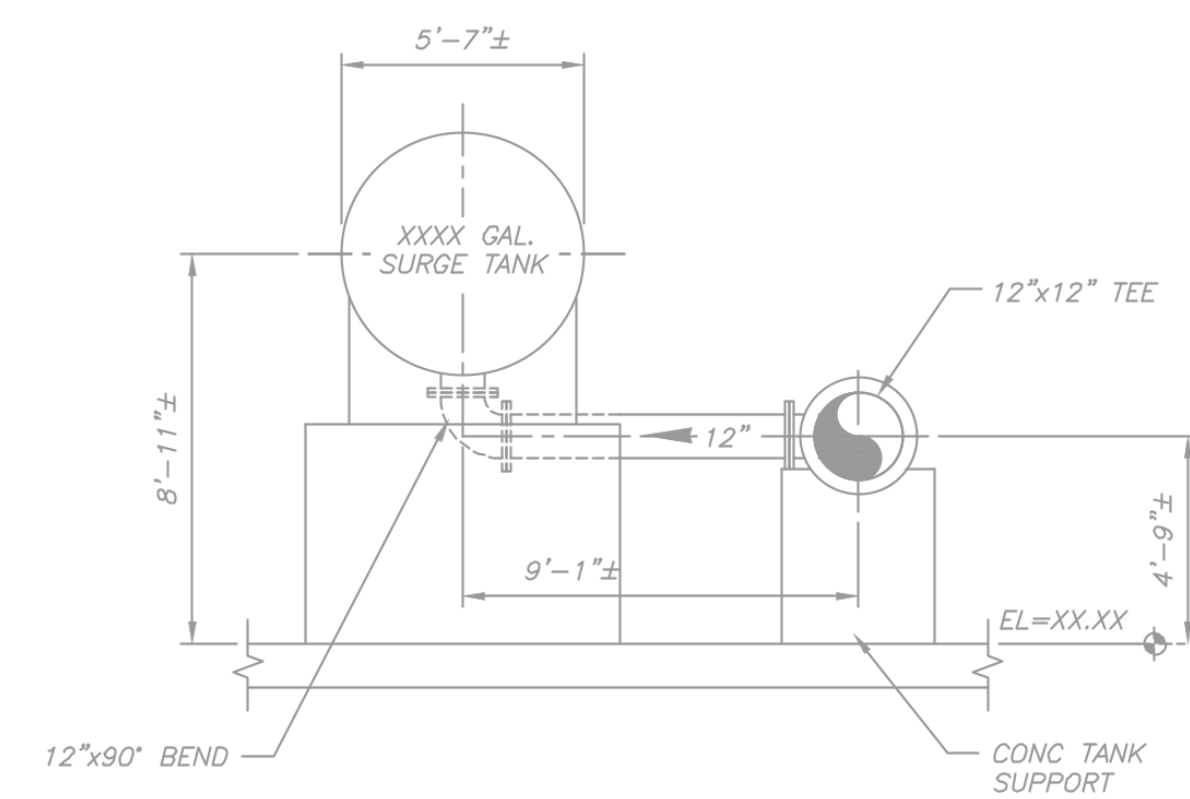
- NOTES:
1. CITY TO CLOSE VALVE DURING MODIFICATIONS (ONLY IF APPLICABLE).
  2. REPLACE EXISTING NUTS, BOLTS AND GASKETS, WITH NEW 316 STAINLESS STEEL NUTS AND BOLTS AND GASKET WITH GALVANIC PROTECTION WITH TORQUE WRENCH AND TORQUE PATTERN VALIDATION. DO NOT PAINT STAINLESS STEEL GASKETS FOR 250 PSI WORKING PRESSURE FLANGES SHALL BE 1/8-INCH THICK, RED RUBBER (SBR), HARDNESS 80 (SHORE A), RATED TO 200 DEGREES F, CONFORMING TO ANSI B16.21, AWWA C207, AND ASTM D1330, GRADES 1 AND 2.
  3. PAINT ABOVE GROUND PIPE, FITTINGS, VALVES, AND SURGE TANK. SEE PAINTING SPECIFICATION SECTION FOR SURFACE PREPARATION AND APPLICATION.
  4. PIPE FLANGE SHOULD BE PAINTED BEFORE BOLT AND NUT CONNECTIONS. (STAINLESS STEEL BOLTS AND NUTS NOT TO BE PAINTED).
  5. PIPE FLANGE SHOULD BE PAINTED BEFORE BOLT AND NUT CONNECTIONS. (STAINLESS STEEL BOLTS AND NUTS NOT TO BE PAINTED).
  6. SANDBLAST AREA TO REMOVE RUST. SEE PAINTING SPECIFICATIONS.
  7. PROTECT FLOW METER, FLEXIBLE CONDUIT, BARE WIRE, CONDUIT, AND CLAMPS AT ALL TIMES DURING MODIFICATIONS.



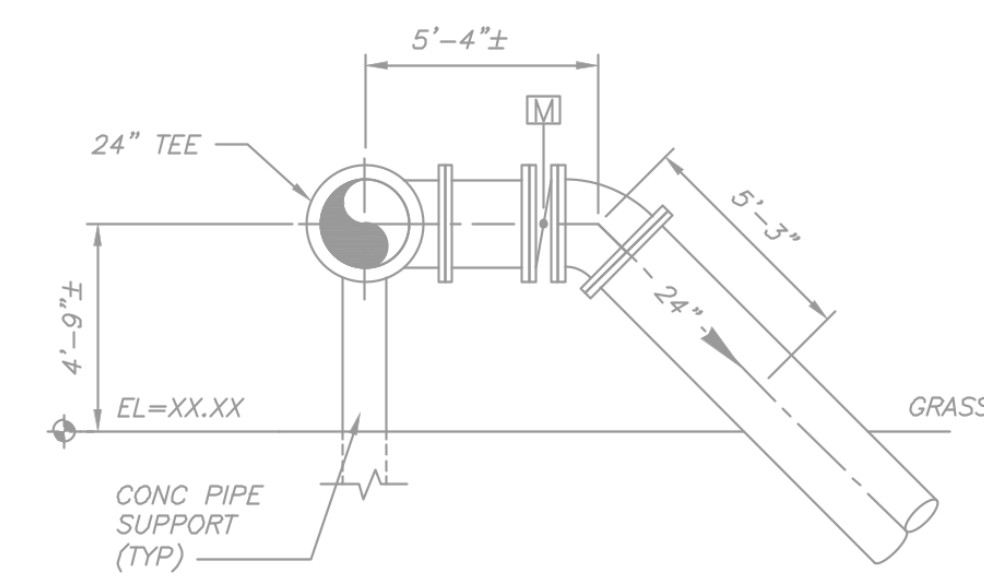
**MODIFICATIONS**  
**SECTION 1**  
 1/4" = 1'-0" FIG-6



**SECTION 2**  
 1/4" = 1'-0" FIG-6



**SECTION 3**  
 1/4" = 1'-0" FIG-6



**SECTION 4**  
 1/4" = 1'-0" FIG-6

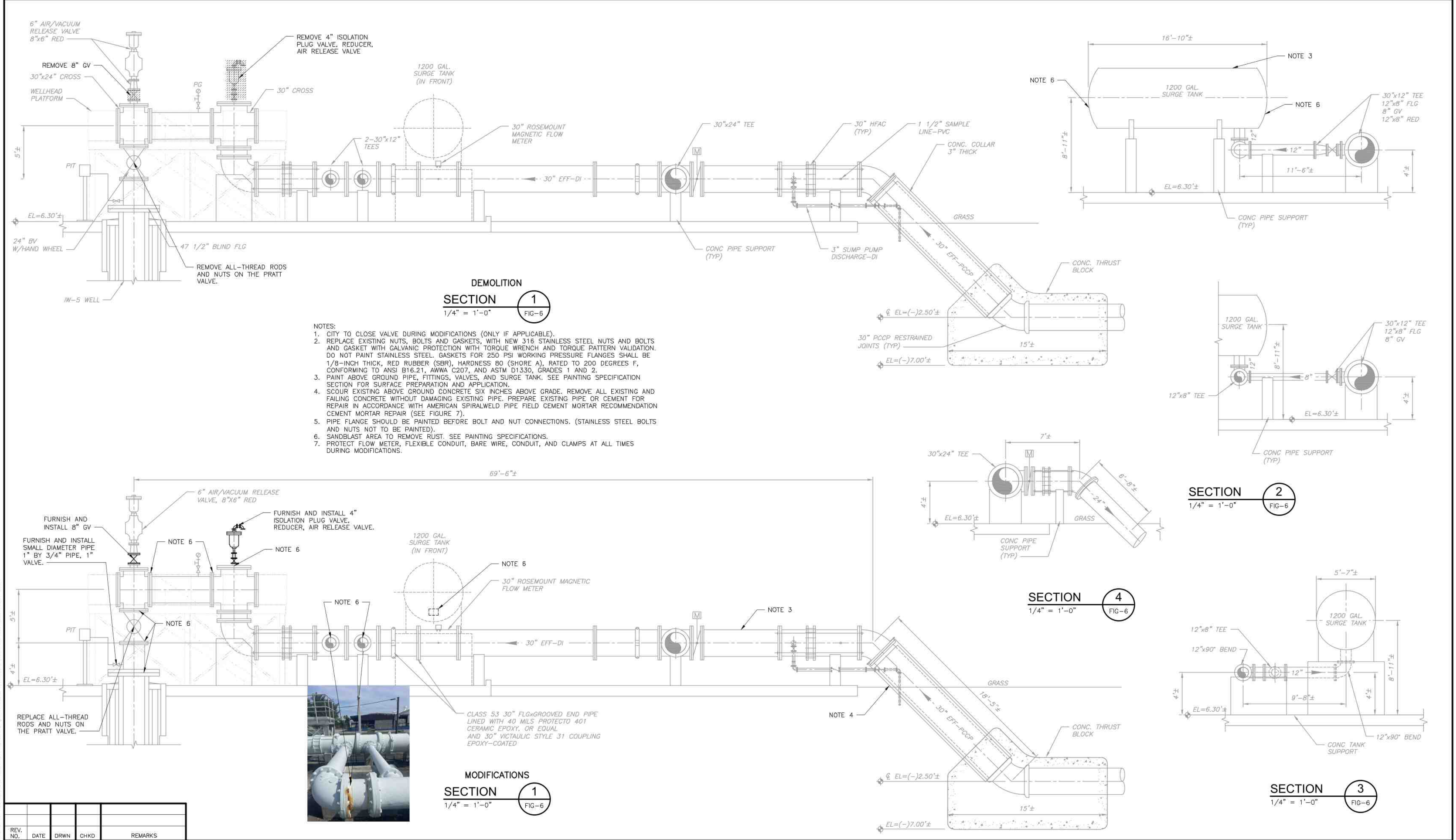
p:\pw.cdmsmith.com\pw\_pl\Documents\6017\233234\02 Project Information\03 Data\30 Reports\04 Figures\FIG 10.dwg  
 08/05/2010 11:51:51 AM  
 ALL RIGHTS RESERVED. THESE DOCUMENTS AND DESIGNS ARE THE PROPERTY OF CDM SMITH  
 NO PART OF THIS DOCUMENT IS TO BE REPRODUCED OR TRANSMITTED IN ANY FORM OR BY ANY MEANS, ELECTRONIC OR MECHANICAL, INCLUDING PHOTOCOPYING, RECORDING, OR BY ANY INFORMATION STORAGE AND RETRIEVAL SYSTEM, WITHOUT THE WRITTEN PERMISSION OF CDM SMITH.

REV. NO.	DATE	DRWN	CHKD	REMARKS



Figure No. 10  
 G.T. Lohmeyer Injection Facility  
 IW-4 Well Head Sections

p:\pw\cdmsmith.com\pw\PL\1\Documents\6017\233234\02 Project Information\03 Data\30 Reports\04 Figures\FIG 11.dwg  
20170728 11:00:58 AM  
PL 1  
ALL RIGHTS RESERVED. NO PARTS OF THIS DOCUMENT OR ANY INFORMATION CONTAINED HEREIN, INCLUDING THE NAMES OF PRODUCTS OR SERVICES, MAY BE REPRODUCED OR TRANSMITTED IN ANY FORM OR BY ANY MEANS, WITHOUT THE WRITTEN PERMISSION OF CDM SMITH.



REV. NO.	DATE	DRWN	CHKD	REMARKS



Figure No. 11  
G.T. Lohmeyer Injection Facility  
IW-5 Well Head Sections

Event 191  
Q&A

Question No.	Question	Response
1	Is there an Engineers estimate available for Bid Bond purposes.	There is not an Engineer's estimate. The 2019 MIT was awarded for \$764,750 and it had additional electrical scope not included in this bid.
2	Per the specifications, the brushing & MIT at all IW's are to be completed by December 30, 2023. It is highly unlikely to complete Phase 1 & 2 at all 5 IW's by the end of December. Please consider new due dates.	The Contractor's schedule will be reviewed when awarded to ensure all IWs are completed within the 120 days in the Contract. Actual dates will depend on when the City can award and execute the Contract.
3	An additional question: Following brushing, if injectivity is not restored to pressure/flows observed during previous cleaning, will additional brushing be required? Will the contractor be paid for additional brushing?	Additional brushing will be required if injectivity is not restored to pressure/flows observed during previous cleaning. Additional brushing, if needed, will occur following post brushing, video survey, specific injectivity Test, referenced in 3.01.G and 3.02.G of the Mechanical Integrity Testing Section (332113.05) has been completed and is considered included under Line Details, Line 1. Line Detail, Line 1 will also include activities not included in any other Line Detail.
4	As discussed during the pre-bid meeting, it is understood that the isolation valves will not be replaced. Will costs incurred by the contractor in repairing leaky isolation valves be paid under the contingency items of the contract?	Yes, repairing leaky isolation valves will be paid under, Special Conditions, 09, Allowance, Owner's Contingency. Refer to 2.02 of Summary of Work Section (011101) and, refer to 1.02.L of Measurement and Payment Section (012000).
5	Will the contractor be considered on Standby during valve repair?	No, repairing leaky isolation valves will not be considered standby time or waiting time, the valve leak can be heard during mobilization, when standing near the valve exterior, so schedule and notify the repair team accordingly, refer to 2.02 under Scope of Work Section (011101)
6	Will impacts to the schedule due to delays associated with valve replacement be addressed with a change in Contract time?	No, the valves will not be replaced.
7	Will the contractor be responsible for alternate leak repairs if utilizing epoxy as stated on 2.02 Isolation Valve Leak Repair does not provide an adequate seal?	Yes, the Contractor shall propose an alternate leak repair method.

Event 191  
Q&A

8	As discussed during the pre-bid meeting, will potable water be supplied by the City with an unmetered connection requiring a RPZ backflow prevention device installed in series?	It will be the responsibility of the Contractor to obtain a hydrant meter from the City's Building Department, install with dual RPZ backflow devices in series, and submit monthly meter reads and monthly payments to the City for all potable water used on the project.
9	Additional brushing was discussed during the pre-bid meeting. Could the City please provide detail on what is meant by "additional"?	Additional brushing is for brushing after specification 3.01.E and 3.02.A of the Mechanical Integrity Testing Section (332113.05) has been completed. Additional brushing, if needed, will occur following post brushing, video survey, specific injectivity Test, referenced in 3.01.G and 3.02.G of the Mechanical Integrity Testing Section (332113.05) has been completed.
10	How will it be determined if brushing and cleaning are acceptable? Will it be based on the video survey or injectivity?	It will be based on a combination of both factors.
11	Could the City please clarify if only the piping needs to be painted or all pipe, tanks, appurtenances, etc. will require paint?	All pipes, fittings, valves, surge tanks, and other appurtenances for five deep injections wells need to be painted per figures and specifications (but not the blue flow meters). Refer to 1.02.I of Measurement and Payment Section (012000).
12	Following brushing, if injectivity is not restored to pressure/flows observed during previous cleaning, will additional brushing be required? Will the contractor be paid for additional brushing?	Additional brushing will be required if injectivity is not restored to pressure/flows observed during previous cleaning. Additional brushing, if needed, will occur following post brushing, video survey, specific injectivity Test, referenced in 3.01.G and 3.02.G of the Mechanical Integrity Testing Section (332113.05) has been completed and is considered included under Line Details, Line 1. Line Detail, Line 1 will also include activities not included in any other Line Detail.

**ADDENDUM NO. 1**

Event 191  
GEORGE T. LOHMEYER WWTP DEEP INJECTION WELL CLEANING

ISSUED: November 29, 2023

This addendum is being issued to make the following changes:

- 1. The **Pre-Bid Meeting Date** has been extended to Wednesday, December 6, 2023, at 10:00AM (local time).

George T. Lohmeyer Regional Wastewater Treatment Plant\*  
 1765 SE 18th St  
 Fort Lauderdale, FL 33316

\*Note: This location is a secured facility. Access to the site visit is only available to pre-approved plan holders originating from the City of Fort Lauderdale Plans Request Form. Non-approved attendees will not be allowed to participate in the site visit. To avoid any issues, Plans Custodians should bring proof of approval to the site visit.

- 2. The **Question & Answer Deadline** has been extended to Friday, December 8, 2023, at 2:00PM (local time).

- 3. The **Proposal Due Date** has been extended to Friday, December 15, 2023, at 2:00PM (local time).

All other terms, conditions, and specifications remain unchanged.

Erick Martinez  
Senior Procurement Specialist

Company Name: \_\_\_\_\_  
(please print)

Bidder's Signature: \_\_\_\_\_

Date: \_\_\_\_\_





City of Fort Lauderdale • Procurement Services Division  
100 N. Andrews Avenue, 619 • Fort Lauderdale, Florida 33301  
954-828-5933 Fax 954-828-5576  
[purchase@fortlauderdale.gov](mailto:purchase@fortlauderdale.gov)

## ADDENDUM NO. 2

Event 191  
GEORGE T. LOHMEYER WWTP DEEP INJECTION WELL CLEANING

ISSUED: December 15, 2023

This addendum is being issued to make the following change:

1. The Bid Due Date has been extended to Friday, December 22, 2023, at 2:00PM (local time).

All other terms, conditions, and specifications remain unchanged.

Erick Martinez  
Senior Procurement Specialist

Company Name: \_\_\_\_\_  
(please print)

Bidder's Signature: \_\_\_\_\_

Date: \_\_\_\_\_